

REV	DATE	DESCRIPTION	ECO	BY	C'H'K.
C	01/09/2019	MARKING DETAILS UPDATED	50616	PB	RG

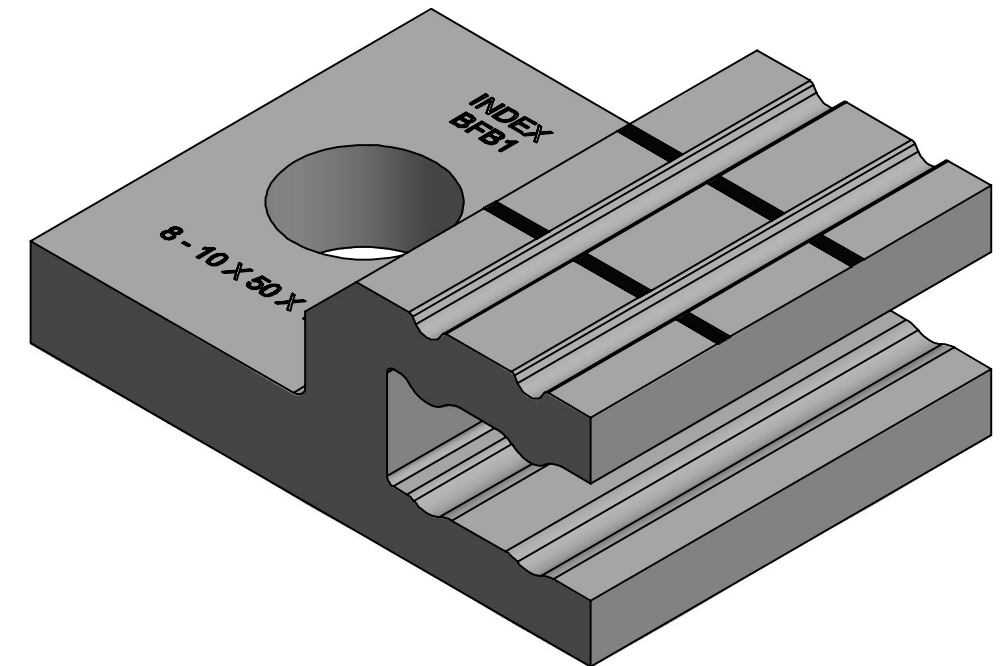
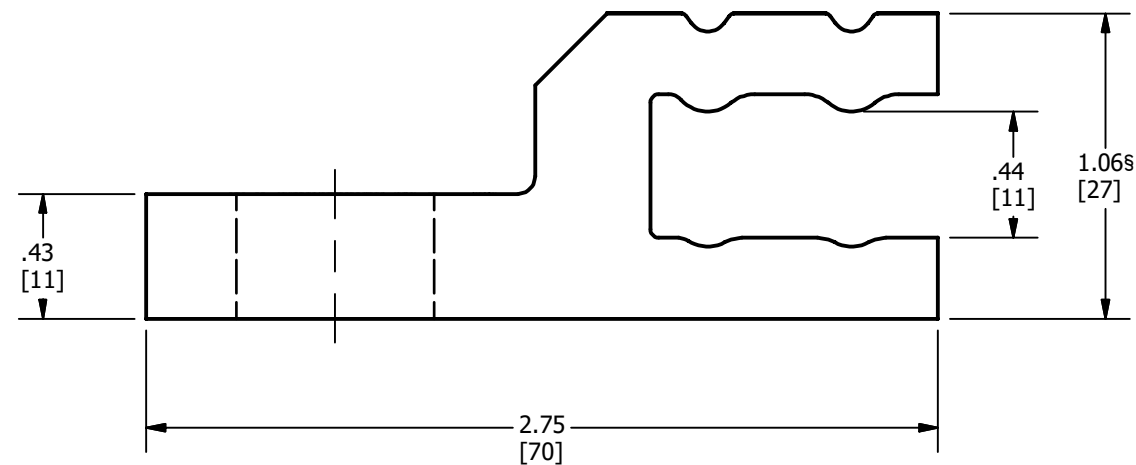
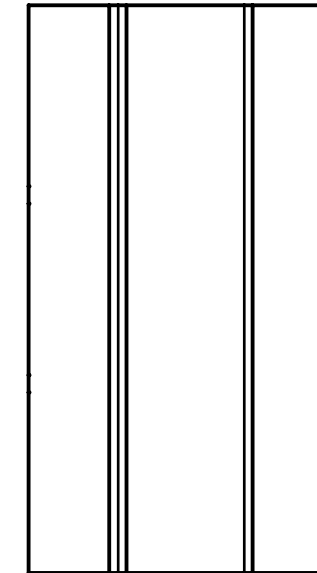
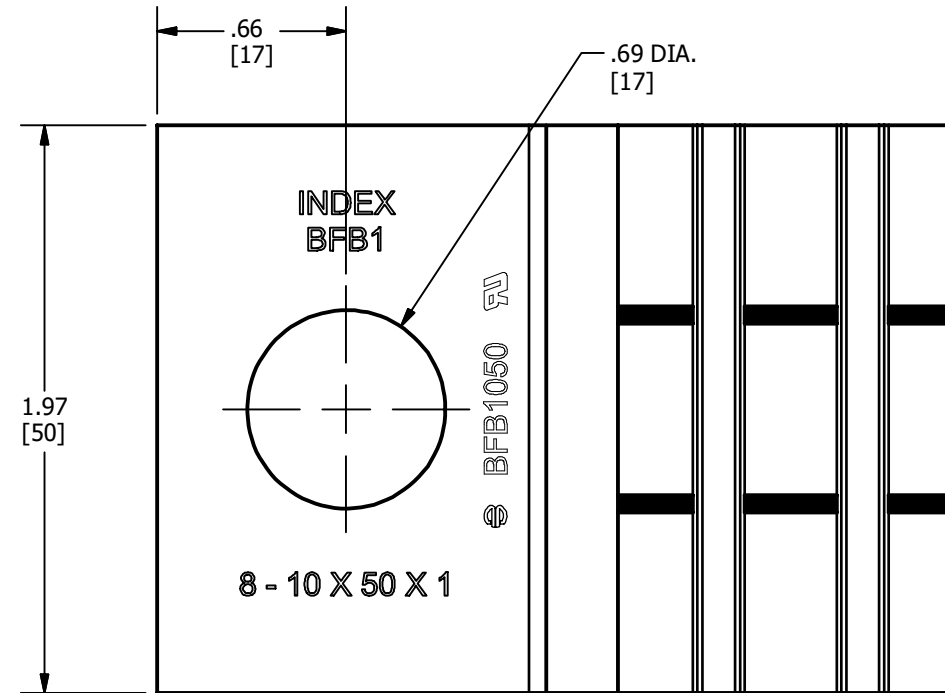

NOTES:

1. DIMENSIONS IN BRACKETS [] ARE IN MILLIMETERS ROUNDED OFF TO THE NEAREST MILLIMETER, UNLESS OTHERWISE SPECIFIED AND ARE FOR REFERENCE ONLY.
2. MATERIAL : TIN-PLATED COPPER.
3. ACCOMMODATES # SHEETS x SHEET WIDTH X SHEET THICKNESS:
10 x 50mm x 1mm
8 x 50mm x 1mm
4. THREE CRIMPS REQUIRED USING INDENTOR "UBFB1" AND FLAT DIE "UBFBF".

TO ORDER BURNDY® PRODUCTS CALL		FLEXIBLE BUS CONNECTOR 10 X 50MM	
UNITED STATES		ITEM NO: 50077544	
1-800-346-4175 (LONDONDERRY, NH)		CAT. NO: BFB1050T58	
CANADA:		DRAWN BY: C.VIMAL 11/10/2016	
1-800-361-6975 (QUEBEC)		CHECKER: B.MANIKANDAN 11/10/2016	
1-800-387-6487 (ALL OTHER PROVINCES)		DSN APRVL: L.TROMBLEY 11/16/2016	
FOR PRODUCT INFO: http://www.burndy.com		MFG APRVL: J.HEAD 11/18/2016	
		QA APRVL: T.WATTS 11/17/2016	
		MKT APRVL: --	
		PROD FAM: --	
		DRAWING NO	
		50077545	
		REV	
		C	
		SHEET 1 OF 1	