

CATALOG NUMBER	ITEM NUMBER	WIRE RANGE	HEX KEY	TORQUE IN-LBS
1PBS750HD	50073393	#2 AWG TO 750 KCMIL CLASS B, C	3/8"	500

REV	DATE	DESCRIPTION	ECO	BY	C'H'K.
c	02/11/2020	UPDATED PART DIMENSIONS	52997	JL	TR

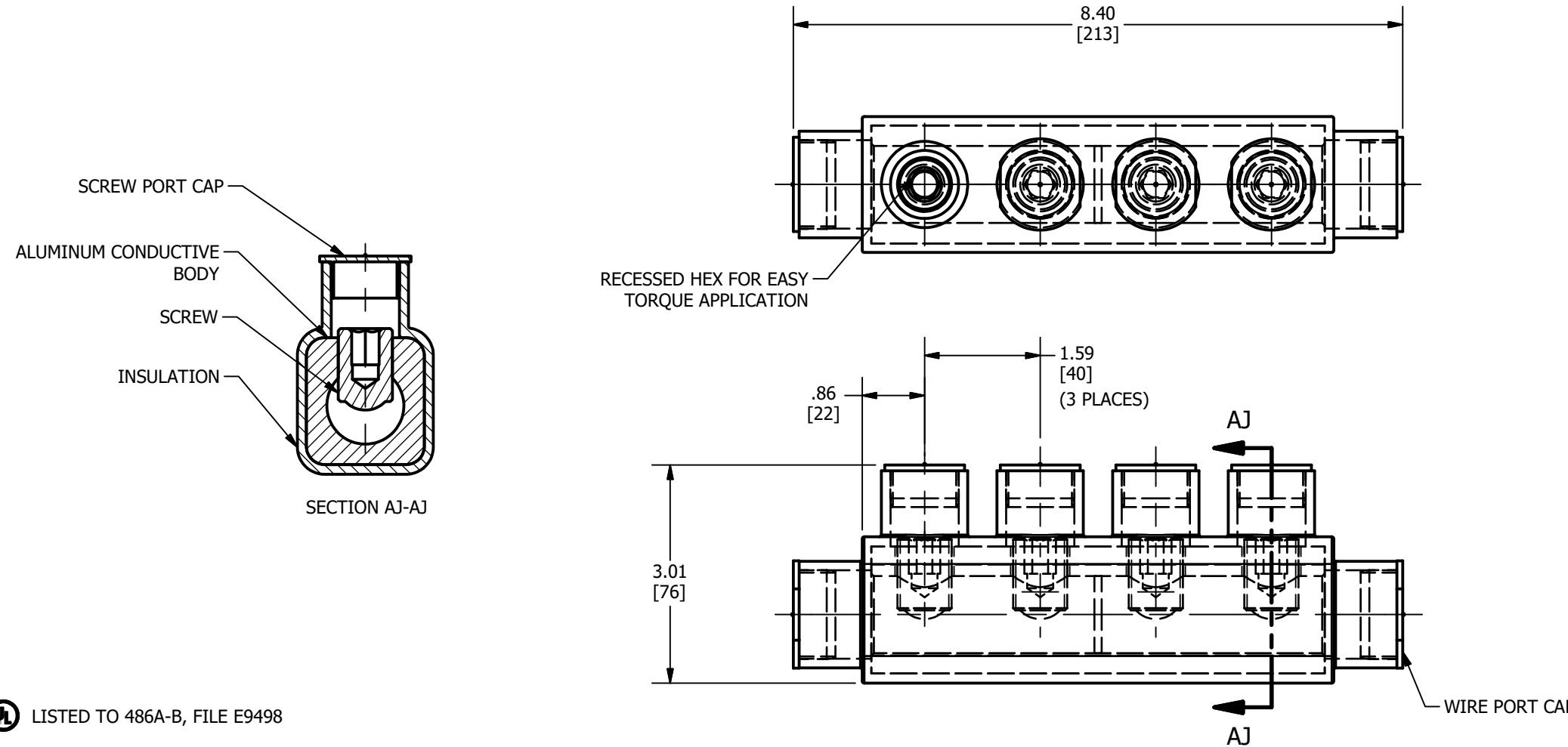

1PLD 750 HD
 HEAVY DUTY
 WIRE SIZE ACCOMMODATED (AL/CU) STR.
 BURNDY INSULATED SPLICE

LISTED TO 486A-B, FILE E9498

NOTES:

1. DIMENSIONS IN BRACKETS [] ARE IN MILLIMETERS ROUNDED OFF TO THE NEAREST MILLIMETER, UNLESS OTHERWISE SPECIFIED AND ARE FOR REFERENCE ONLY.
2. THIS DRAWING TO BE INTERPRETED PER ASME Y14.5M-2009.
3. MATERIAL: BODY - TIN PLATED ALUMINUM
 SCREW - CLEAR COATED ALUMINUM
 INSULATION - PLASTISOL
 CAPS - POLYETHYLENE
- 4 OPERATING TEMPERATURE - -40°C TO 135°C.
- 5 VOLTAGE RATING - 600 V.
- 6 AMPERAGE RATING - 535 AMPS. VALUES BASED ON NFPA 70, TABLE 310.15(B)(16). VALUES MAY VARY BASED UPON AMBIENT CONDITIONS AND CONDUCTOR PROPERTIES.

FEATURES	BENEFITS
PLASTISOL COVERED AL 6060-T6 BODY	SAVES TIME, LOWERS INSTALLATION COST, ELIMINATES TAPING
OXIDE INHIBITOR IS PREFILLED	INHIBITS MOISTURE AND CONTAMINANTS FROM ENTERING THE CONTACT AREA
WIRE AND SCREW PORT COVERS	PROTECTS AGAINST CONTAMINATION AND ACCIDENTAL CONTACT OF ENERGIZED PARTS.

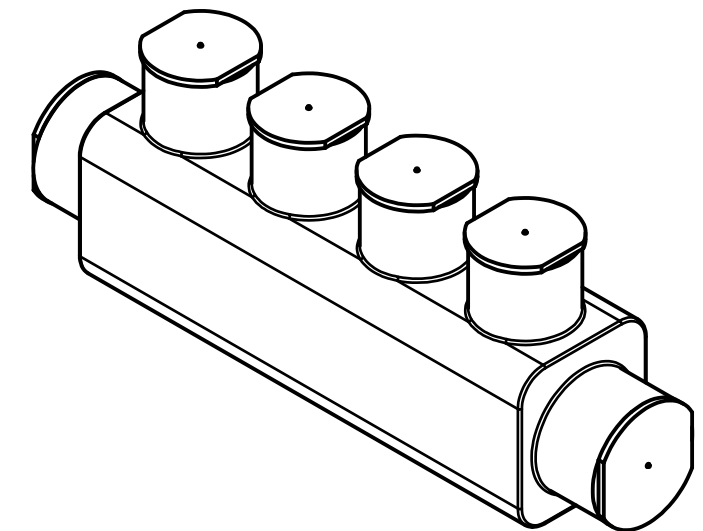

3D VIEW

TO ORDER BURNDY® PRODUCTS CALL		FULLY INSULATED SPLICES - UNITAP™	
UNITED STATES 1-800-346-4175 (LONDONDERRY, NH)		ITEM NO: 50073393	
CANADA: 1-800-361-6975 (QUEBEC) 1-800-387-6487 (ALL OTHER PROVINCES)		CAT. NO: 1PBS750HD	
FOR PRODUCT INFO: http://www.burndy.com		DRAWN BY: C.VIMAL 1/20/2017	
		CHECKER: B.MANIKANDAN 1/19/2017	
		DSN APRVL: T.REYNOLDS 2/8/2017	
		MFG APRVL: --	
		QA APRVL: B.POST 2/8/2017	
		MKT APRVL: M.BALLY 2/9/2017	
		PROJ FAM: --	
		DRAWING NO	
		50079816	
		REV	
		C	
		SHEET 1 OF 1	