

CATALOG NUMBER	ITEM NUMBER	PORTS	LENGTH "L"	WIRE RANGE	HEX KEY	TORQUE, IN-LBS
BIBD7502HD	50073395	2	2.63	#2 AWG TO 750 kcmil Class B, C	3/8"	500
BIBD7503HD	50073396	3	4.00			
BIBD7504HD	50073397	4	5.38			
BIBD7505HD	50073398	5	6.75			
BIBD7506HD	50073399	6	8.13			
BIBD7508HD	50073400	8	10.88			
BIBD75010HD	50073401	10	13.63			
BIBD75012HD	50073402	12	16.38			

REV	DATE	DESCRIPTION	ECO	BY	C'H.K.
D	03/12/2019	UPDATED AS PER MARKUP	51029	YR	VS

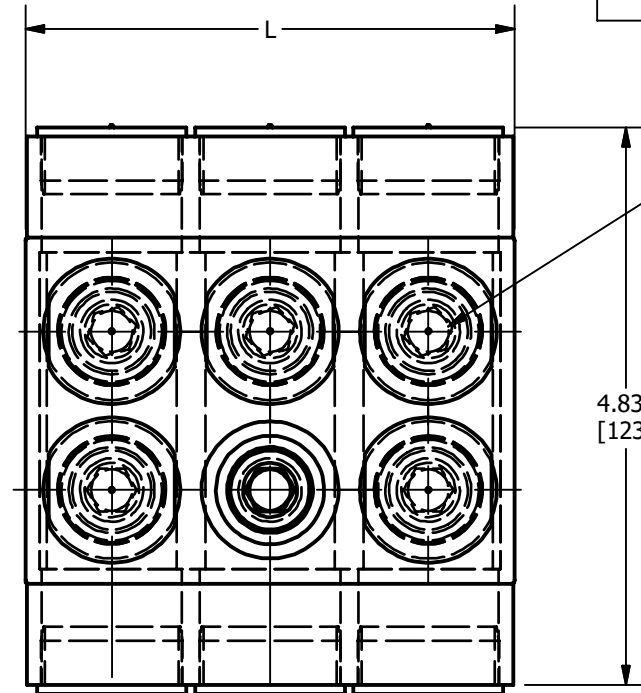
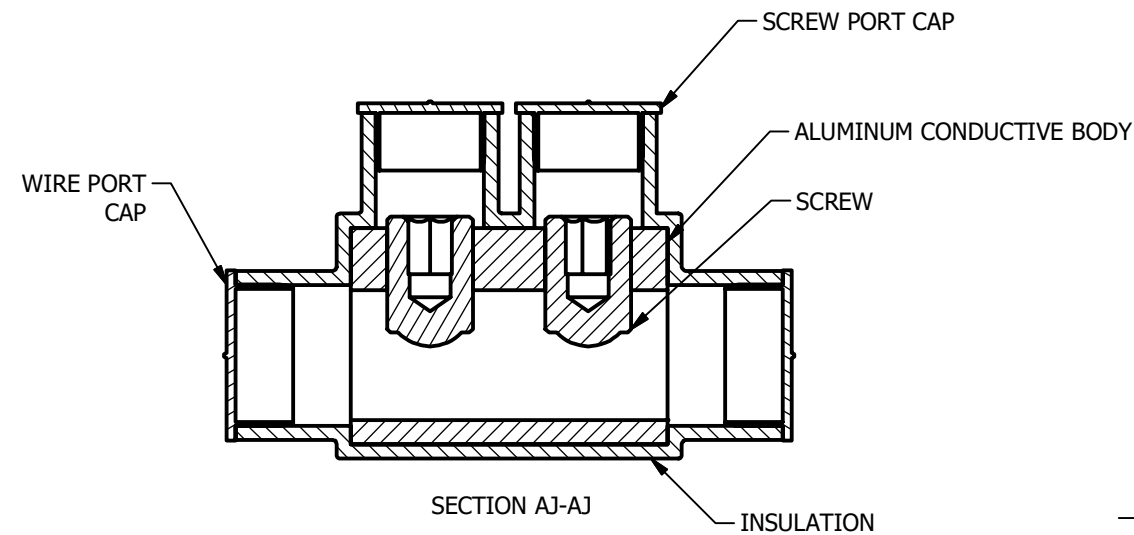

BIBD 750 3 HD
 HEAVY DUTY
 WIRE PORTS
 WIRE SIZE ACCOMMODATED (AL/CU) STR.
 BURNDY INSULATED BLOCK
 DOUBLE SIDE ENTRY

LISTED TO 486A-B, FILE E9498

NOTES:

- DIMENSIONS IN BRACKETS [] ARE IN MILLIMETERS ROUNDED OFF TO THE NEAREST MILLIMETER, UNLESS OTHERWISE SPECIFIED AND ARE FOR REFERENCE ONLY.
- THIS DRAWING TO BE INTERPRETED PER ASME Y14.5M-2009.
- MATERIAL: BODY - TIN PLATED ALUMINUM
 SCREW - CLEAR COATED ALUMINUM
 INSULATION - PLASTISOL
 CAPS - POLYETHOLENE
- OPERATING TEMPERATURE - -40°C TO 135°C.
- VOLTAGE RATING - 600 V.
- AMPERAGE RATING - 535 AMPS. VALUES BASED ON NFPA 70, TABLE 310.15(B)(16). VALUES MAY VARY BASED UPON AMBIENT CONDITIONS AND CONDUCTOR PROPERTIES.
- BOTH SET SCREWS MUST BE USED PER CONDUCTOR. CONDUCTORS CAN NOT BE INSTALLED FROM OPPOSITE SIDES OF THE SAME PORT USING ONLY ONE 1 SCREW PER CONDUCTOR.

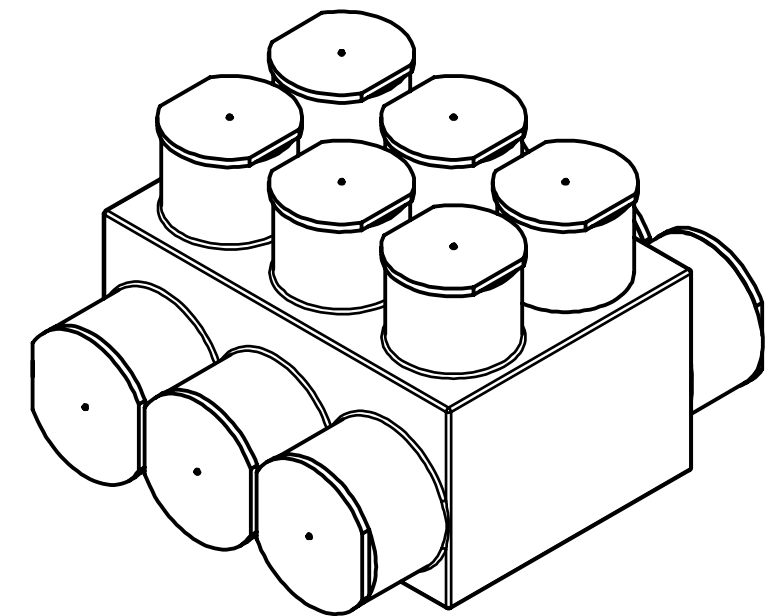
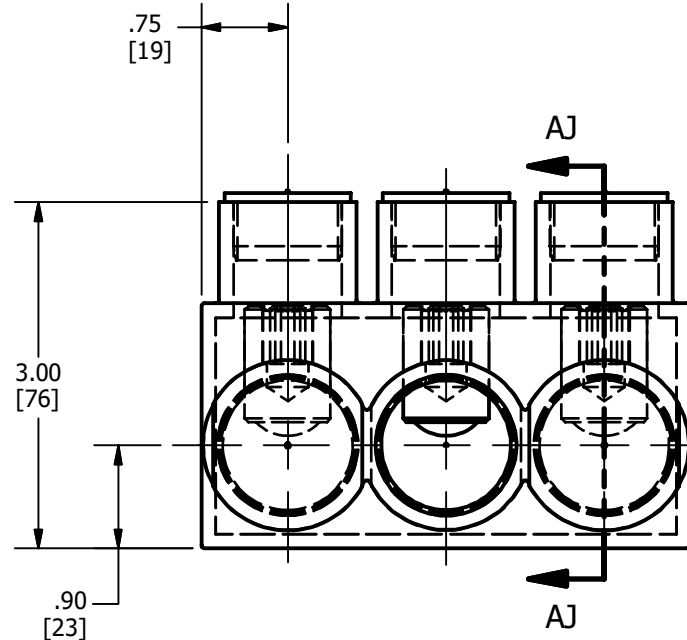

3D VIEW

FEATURES	BENEFITS
PLASTISOL COVERED AL 6060-T6 BODY	SAVES TIME, LOWERS INSTALLATION COST, ELIMINATES TAPING
OXIDE-IN HIBITOR IS PREFILLED	INHIBITS MOISTURE AND CONTAMINATES FROM ENTERING THE CONTACT AREA
WIRE AND SCREW PORT COVERS	PROTECTS AGAINST CONTAMINATION AND ACCIDENTAL CONTACT OF ENERGIZED PARTS.

TO ORDER BURNDY® PRODUCTS CALL		FULLY INSULATED DISTRIBUTION BLOCKS-UNITAP™	
UNITED STATES 1-800-346-4175 (LONDONDERRY, NH)		ITEM NO: SEE TABLE	
CANADA: 1-800-361-6975 (QUEBEC) 1-800-387-6487 (ALL OTHER PROVINCES)		CAT. NO: SEE TABLE	
FOR PRODUCT INFO: http://www.burndy.com		DRAWN BY: C.VIMAL 01/20/2017	
		CHECKER: B.MANIKANDAN 01/20/2017	
		DSN APRVL: --	
		MFG APRVL: --	
		QA APRVL: --	
		MKT APRVL: --	
		PROD FAM: --	
		DRAWING NO	
		50079817	
		REV	
		D	
		SHEET 1 OF 1	