

BURNDY® PRODUCTS - HYLUG™ & HARDWARE																		
ITEM NUMBER	CATALOG NUMBER	ACCOMMODATES ACCC® CONDUCTOR		CONTAINS HARDWARE KIT CAT #	CTC NUMBER	DIMENSIONS								INSTALLATION TOOLING (NOT INCLUDED)			APPROXIMATE WEIGHT LBS.	
		CODE WORD	SIZE			C	D	L	N	O.D.	I.D.	T	H	DIE INDEX	Y45	Y46		Y60
10103092	BYNA590MRT15HACCC	MAHAKAM	545 mm <sup>2</sup>	TMH24	600-253-6	3.22 [82]	3.95 [100]	15.7 [399]	.62 [16]	1.97 [50]	1.25 [32]	.52 [13]	3.92 [100]	727	---	---	L727W	3.1
10103093	BYNA590MRT15ACCC			---														2.8

REV	DATE	DESCRIPTION	ECO	BY	C'H'K.
B	05/07/2018	CHANGED 727W TO L727W	46297	KV	NJS

5 CATALOG NO. TMH24 HARDWARE KIT CONSIST OF	
QTY.	DESCRIPTION
4	BOLT, HEX HEAD 1/2"-13 X 2" LONG
4	HEX NUT, 1/2"-13
4	FLAT WASHER 1/2"
4	RESILIENT WASHER 1/2"

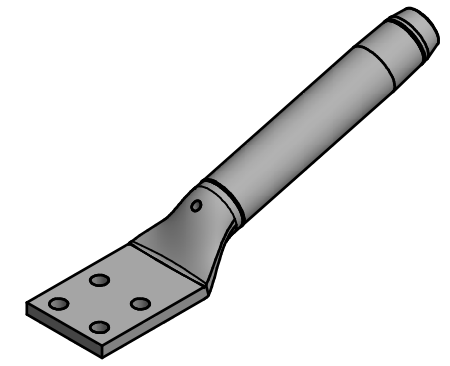
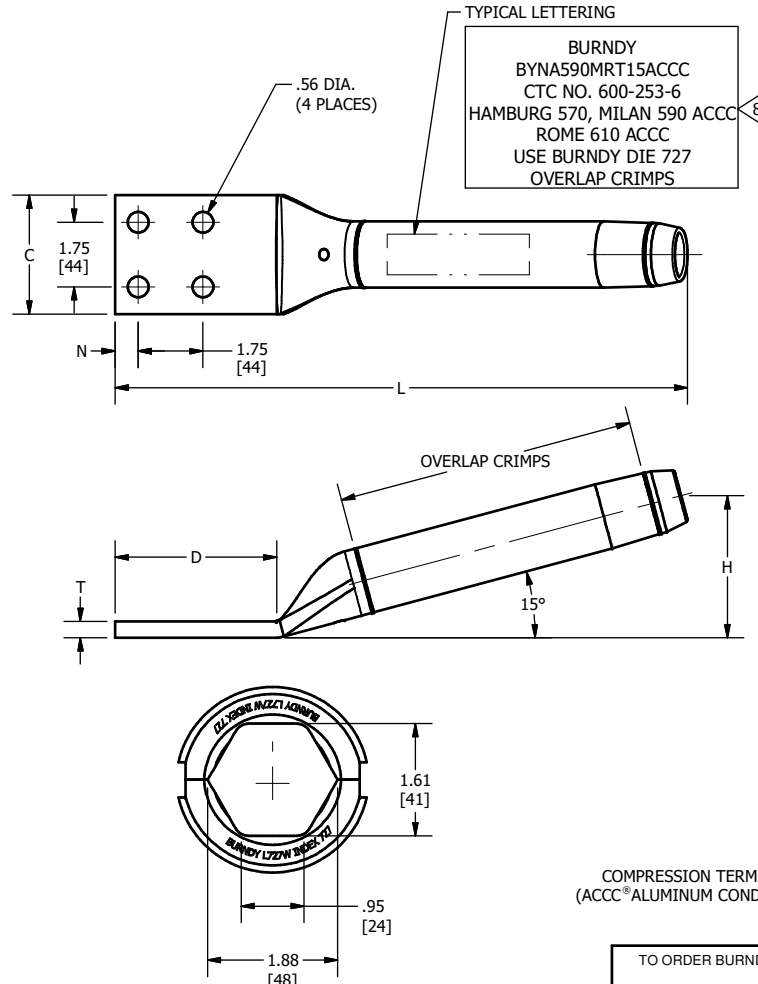

3D VIEW

COMPRESSION TERMINAL CONNECTOR FOR (ACCC®)ALUMINUM CONDUCTOR COMPOSITE CORE

L727W (=AFTER COMPRESSION)

- NOTES:**
- MATERIAL:
    - CONNECTOR, ALUMINUM ALLOY, NO-OX-ID COATED
    - ALUMINUM FILLER PLUG
    - TMH24 HARDWARE
      - BOLTS (2024 T4), NUTS (6061 T6) AND FLAT WASHERS, ALUMINUM ALLOY
      - RESILIENT WASHERS, GALVANIZED STEEL
  - DIMENSIONS IN BRACKETS [ ] DENOTE METRIC UNITS [SI UNITS] AND ARE ROUNDED TO THE NEAREST WHOLE NUMBER. UNLESS OTHERWISE SPECIFIED THESE UNITS SHALL BE USED FOR REFERENCE ONLY.
  - DESIGNED FOR CORONA FREE OPERATION TO 230 KV NO ACCESSORIES REQUIRED.
  - CONNECTOR SHALL BE SHIPPED UN-ASSEMBLED.
  - 5 RECOMMENDED TIGHTENING TORQUE: 1/2-13 ALUMINUM HARDWARE: 300 LBS-IN [34 NM].
  - 6 CATALOG NUMBER FOR HYLUG™ WITHOUT HARDWARE ARE CATALOG NUMBERS WITHOUT "H".
  - 7 REFERENCE: 10092621, CONNECTOR INSTALLATION
  - 8 CONNECTOR MARKED WITH MILAN ACCC (O.D. AND TOTAL CROSS SECTION = MAHAKAM ACCC)

TO ORDER BURNDY® PRODUCTS CALL		15" HYLUG & HARDWARE	
UNITED STATES		ITEM NO: SEE TABLE	
1-800-346-4175 (LONDONDERRY, NH)		CAT. NO: SEE TABLE	
CANADA:		DRAWN BY: S.MOORETTY 4/28/2017	
1-800-361-6975 (QUEBEC)		CHECKER: B.MANIKANDAN 4/28/2017	
1-800-387-6487 (ALL OTHER PROVINCES)		DSN APRVL: P.CHAN 4/26/2017	
FOR PRODUCT INFO: <a href="http://www.burndy.com">http://www.burndy.com</a>		MFG APRVL: --	
		QA APRVL: T.WATTS 4/26/2017	
		MKT APRVL: B.ERLITCHER 5/11/2017	
		PROJ FIRM: TRANSMISSION	
		PROJECT #: --	
		DOCUMENT TYPE: SALES	
		REL LEVEL: Released	
		DRAWING NO. 50081944	
		REV B	
		SHEET 1 OF 1	