

REV	DATE	DESCRIPTION	ECO	BY	CHK.
A	06/11/2018	NEW DRAWING CREATION	49237	RB	VS

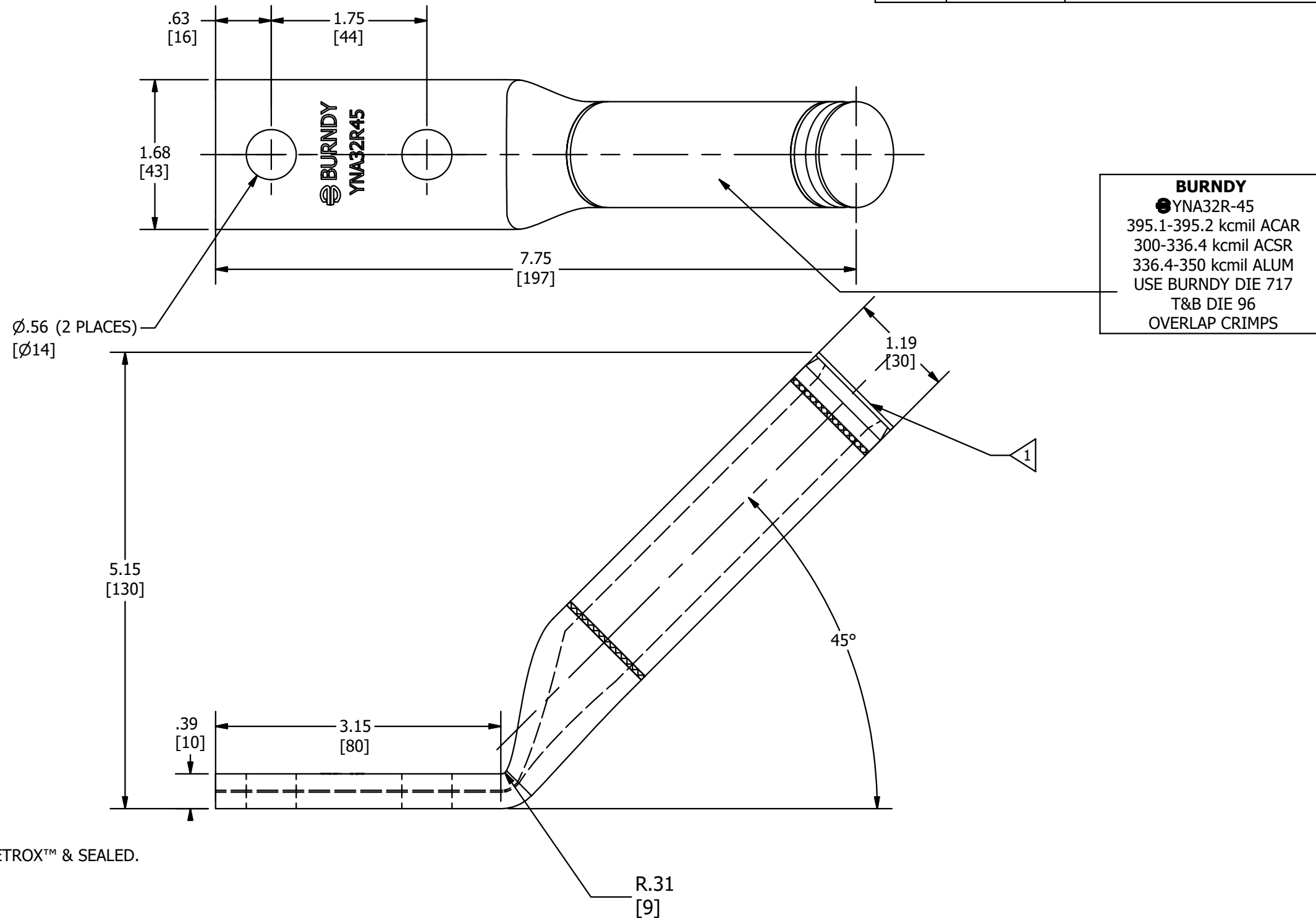

NOTES:

1. BARRELS PRE-FILLED WITH PENETROX™ & SEALED.
2. MATERIAL : ALUMINUM ALLOY
3. THE EQUIVALENT T&B DIE INDEXES ARE LISTED FOR YOUR CONVENIENCE.
4. DIMENSIONS IN BRACKETS [] ARE IN MILLIMETERS ROUNDED OFF TO THE NEAREST MILLIMETER, UNLESS OTHERWISE SPECIFIED AND ARE FOR REFERENCE ONLY.
5. INSTALLATION INSTRUCTIONS ON DWG. 30002494.
6. RECOMMENDED TORQUE: 1/2"DIA. ALUM. BOLTS - 300 IN-LB [34Nm].

TO ORDER BURNDY® PRODUCTS CALL		HYLUG™(ACSR-ACC)<230 K.V.	
UNITED STATES		ITEM NO: 26002768	
1-800-346-4175 (LONDONDERRY, NH)		CAT. NO: YNA32R45	
CANADA:		DRAWN BY: R. BABU 06/11/2018	
1-800-361-6975 (QUEBEC)		CHECKER: V. SAKTHIVEL 06/11/2018	
1-800-387-6487 (ALL OTHER PROVINCES)		DSN APRVL: D. BOUDREAU 06/20/2018	
FOR PRODUCT INFO: http://www.burndy.com		MFG APRVL: R. LAVOIE 06/22/2018	
		QA APRVL: B. POST 06/22/2018	
		MKT APRVL: R. LOVELESS 06/23/2018	
PROD FAM: CM&R	DRAWING NO	REV	
PROJECT #: --	SIZE	50092188	A
DOCUMENT TYPE: SALES	B	SHEET 1 OF 1	
REL LEVEL: Released			