

WIRE SIZE (AWG), AN Aircraft	STUD SIZE	CATALOG NUMBER	C		K		L MAX.	N		T ± .01 [± .25]	Y MAX.	Z MIN.	WIRE STRIP LENGTH ± .03 [± .8]	INSTALLATION TOOLING (ONE CRIMP)
			MAX.	MIN.	MAX.	MIN.		MAX.	MIN.					
12-10 Str. and Sol.	10	YAV10R	.39 [9.9]	.36 [9.1]	.23 [5.8]	.19 [4.8]	.53 [13.5]	.20 [5.0]	.18 [4.5]	.06 [1.5]	.46 [11.7]	.25 [6.4]	5/16" [7.9]	Y6NCB [J1022NC5], Y6NCP1 [J1022NC5], Y1022, Y8MRB1, Y81KFT, Y81KFTMBH, PAT81KT18V, MRE1022B, Y1222CMR## ##- Y122CMR to be used for YAV10 items.
	1/4"	YAV10R3	.48 [12.3]	.45 [11.5]	.28 [7.1]	.26 [6.6]	.56 [14.1]	.24 [6.2]	.22 [5.7]	.05 [1.2]	.50 [12.7]	.28 [7.1]		
20-14 Str. and Sol.	6	YAV14RL33	.27 [6.8]	.23 [5.9]	.15 [3.8]	.14 [3.6]	.36 [9.1]	.14 [3.4]	.12 [2.9]	.05 [1.3]	.45 [11.4]	.17 [4.2]	1/4" [6.4]	
	8	YAV14R1	.33 [8.4]	.29 [7.4]	.18 [4.5]	.16 [4.1]	.36 [9.1]	.18 [4.6]	.14 [3.6]	.04 [1.0]	.48 [12.2]	.25 [6.4]		
10	YAV14R	.33 [8.4]	.29 [7.4]	.23 [5.8]	.19 [4.8]	.36 [9.1]	.18 [4.6]	.14 [3.6]	.04 [1.0]	.48 [12.2]	.25 [6.4]			
22-18 Str. and Sol.	10	YAV18R	.33 [8.4]	.29 [7.4]	.23 [5.8]	.19 [4.8]	.34 [8.6]	.18 [4.6]	.14 [3.6]	.03 [0.8]	.46 [11.7]	.25 [6.4]		

REV	DATE	DESCRIPTION	ECO	BY	C'H'K.
A	11/07/2018	NEW DRAWING CREATION	50231	RB	VS

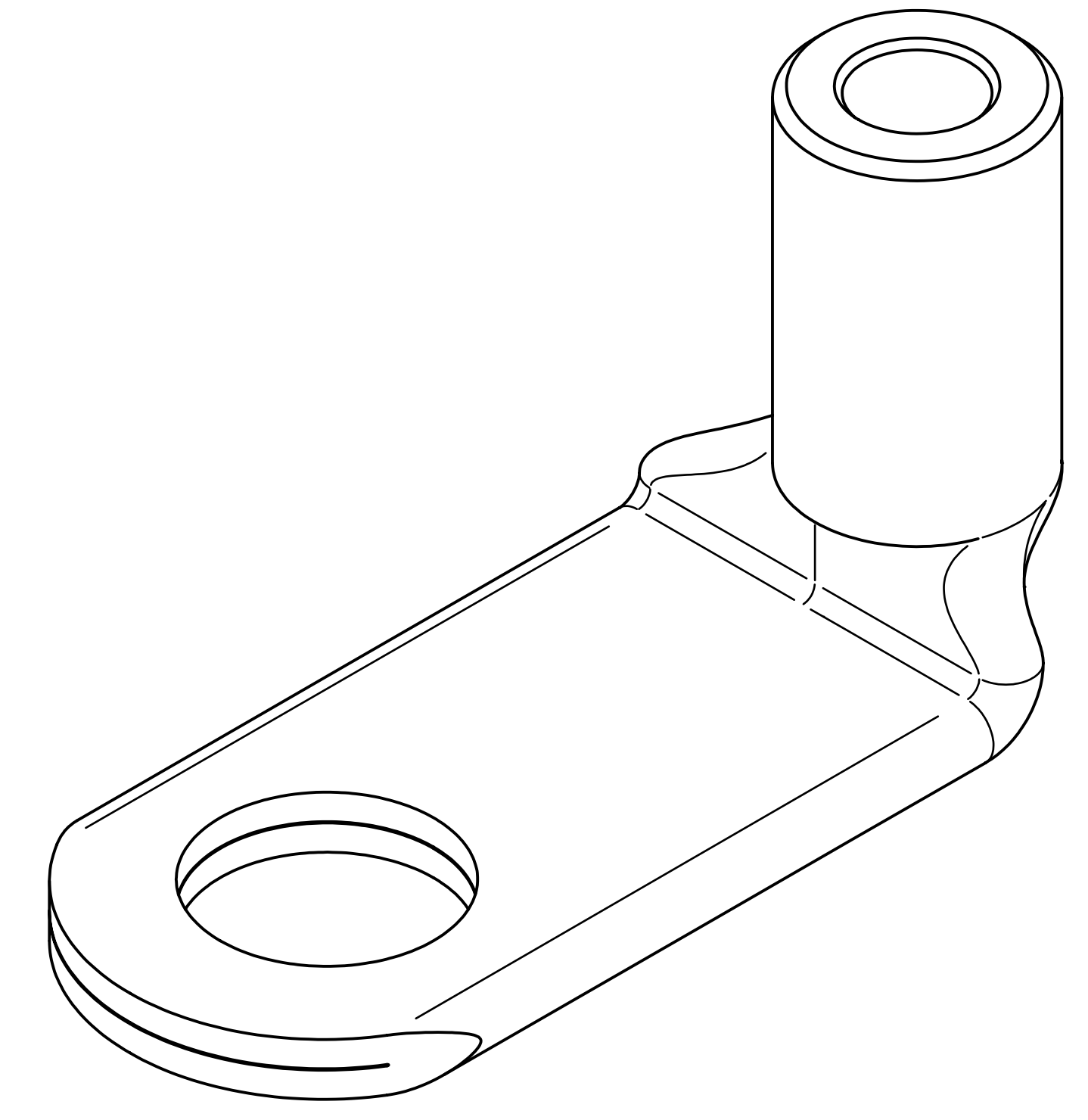
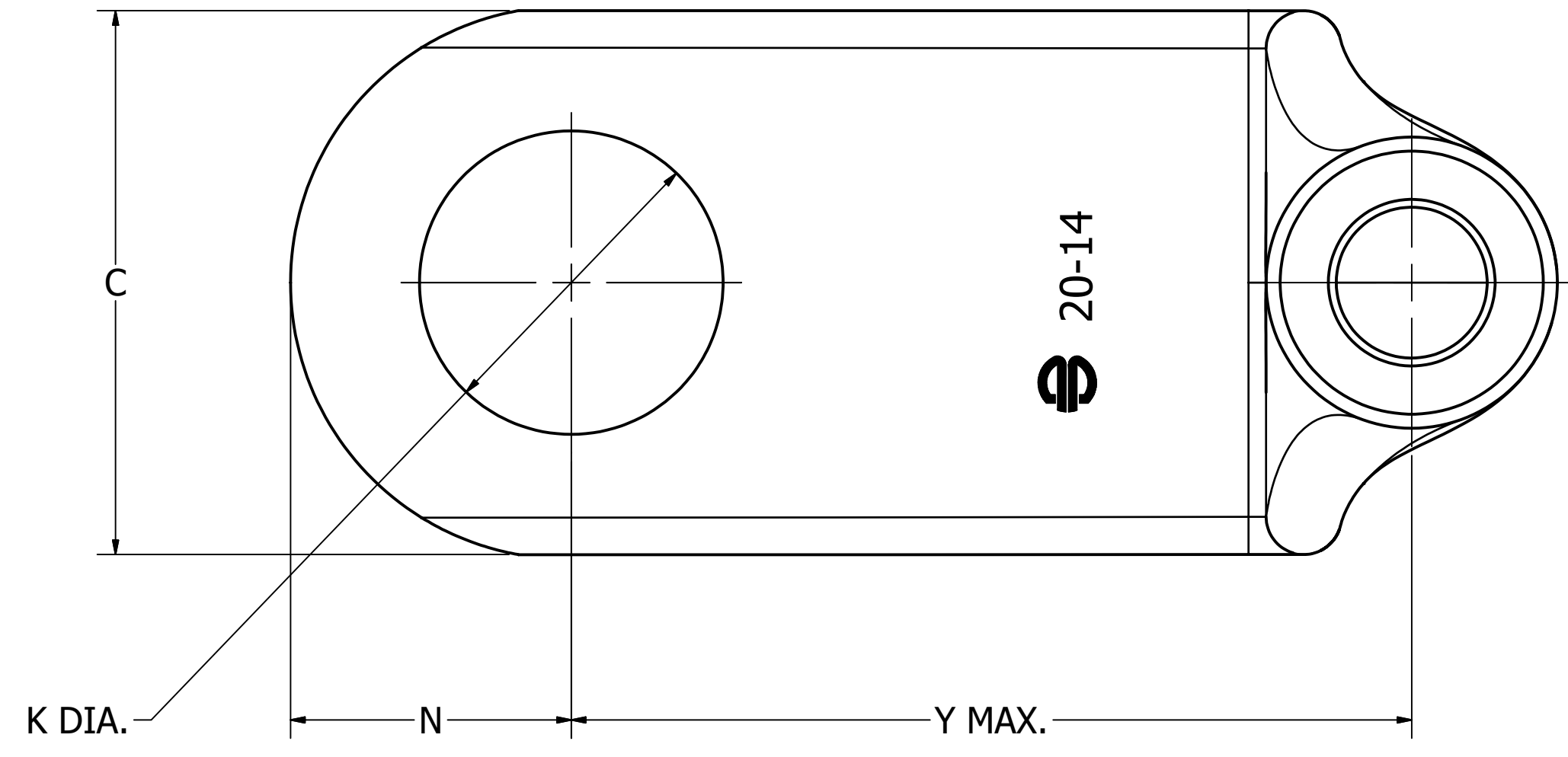
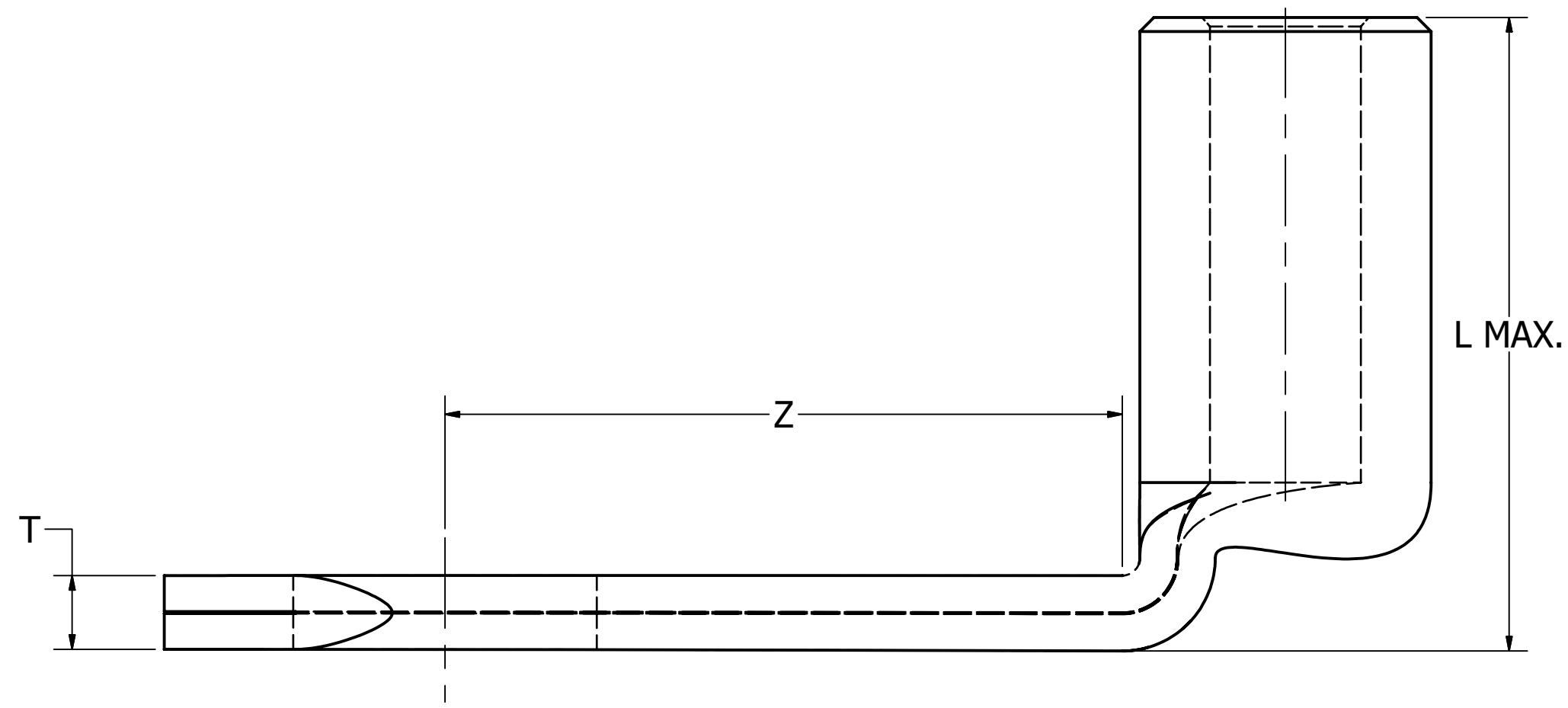

NOTES:

1. TERMINAL: TIN PLATED COPPER
2. DIMENSIONS IN BRACKETS [] ARE IN MILLIMETERS AND ARE FOR REFERENCE ONLY.
3. DIE SETS ARE LISTED IN BRACKETS [] AFTER THEIR RESPECTIVE TOOLS.
4. UL LISTED WIRE CONNECTORS PER UL486A/B (FILE E9498) REQUIREMENTS
5. DISCONTINUED TOOLS: Y6NCP, Y10MRSA, Y10MRPA, EMR20, PATMD1022LI
CONTACT TECH SERVICE FOR INFORMATION ABOUT APPROVED APPLICATIONS (1-800-451-4956)
6. MEETS REQUIREMENTS OF SAE-AS7928

TO ORDER BURNDY® PRODUCTS CALL		HYLUG™	
UNITED STATES 1-800-346-4175 (LONDONDERRY, NH)		ITEM NO: SEE TABLE	
CANADA: 1-800-361-6975 (QUEBEC) 1-800-387-6487 (ALL OTHER PROVINCES)		CAT. NO: TYPE YAV-R	
FOR PRODUCT INFO: http://www.burndy.com		DRAWN BY: RBABU 11/07/2018	
		CHECKER: V.SAKTHIVEL 11/07/2018	
		DSN APRVL: K.CASTONGUAY 12/13/2018	
		MFG APRVL: --	
		QA APRVL: B.POST 11/13/2018	
		MKT APRVL: M.BAILLY 11/10/2018	
		PROD FAM: --	
		PROJECT #: --	
		SIZE	
		D	
		DRAWING NO	
		50094165	
		SHEET 1 OF 1	
		REV	
		A	