

REV	DATE	DESCRIPTION	ECO	BY	C'H'K.
A	10/31/2018	NEW DRAWING CREATION	50182	YR	VS

WIRE SIZE (AWG)	STUD SIZE	CATALOG NUMBER	C		K		L MAX.	N		T ±.01 [±.25]	Y MAX.	Z MIN.	MAX. WIRE INSUL. DIA. ACCOM.	WIRE STRIP LENGTH ±.03 [±.8]	COLOR CODE	INSTALLATION TOOLING (ONE CRIMP)
			MAX.	MIN.	MAX.	MIN.		MAX.	MIN.							
22-18 Str. and Sol.	6	TN186BF	.28 [7.1]	.22 [5.6]	.15 [3.8]	.14 [3.6]	.98 [24.9]	.18 [4.6]	.12 [3.0]	.03 [.8]	.86 [21.8]	.29 [7.4]	.16 [4.2]	3/16" [4.8]	RED	MRE1022NV, MR81A, Y10D, Y1022, M8ND [N10ET9, N14HET15, N10ET23]
	8	TN188BF	.34 [8.6]	.28 [7.1]	.18 [4.5]	.16 [4.1]		.22 [5.6]	.16 [4.1]		.82 [20.8]					
	10	TN1810BF			.23 [5.8]	.19 [4.8]					.84 [21.3]					
16-14 Str. and Sol.	6	TN146BF	.28 [7.1]	.22 [5.6]	.15 [3.8]	.14 [3.6]	.96 [24.4]	.18 [4.6]	.12 [3.0]	.03 [.8]	.84 [21.3]	.27 [6.9]	.18 [4.7]	BLUE		
	8	TN148BF	.33 [8.4]	.27 [6.9]	.18 [4.5]	.16 [4.1]		.98 [24.9]	.21 [5.3]		.15 [3.8]				.83 [21.1]	
	10	TN1410BF	.35 [8.9]	.29 [7.4]	.23 [5.8]	.19 [4.8]			.22 [5.6]		.16 [4.1]				.82 [20.8]	
12-10 Str. and Sol.	6	TN106BF	.33 [8.4]	.27 [6.9]	.15 [3.8]	.14 [3.6]	1.05 [26.7]	.21 [5.3]	.15 [3.8]	.04 [1.0]	.90 [22.9]	.26 [6.6]	.24 [6.0]	YELLOW		
	8	TN108BF	.36 [9.1]	.30 [7.6]	.18 [4.5]	.16 [4.1]		.22 [5.6]	.16 [4.1]		.89 [22.6]					
	10	TN1010BF	.38 [9.7]	.32 [8.1]	.23 [5.8]	.19 [4.8]		.23 [5.8]	.17 [4.3]		.88 [22.4]					

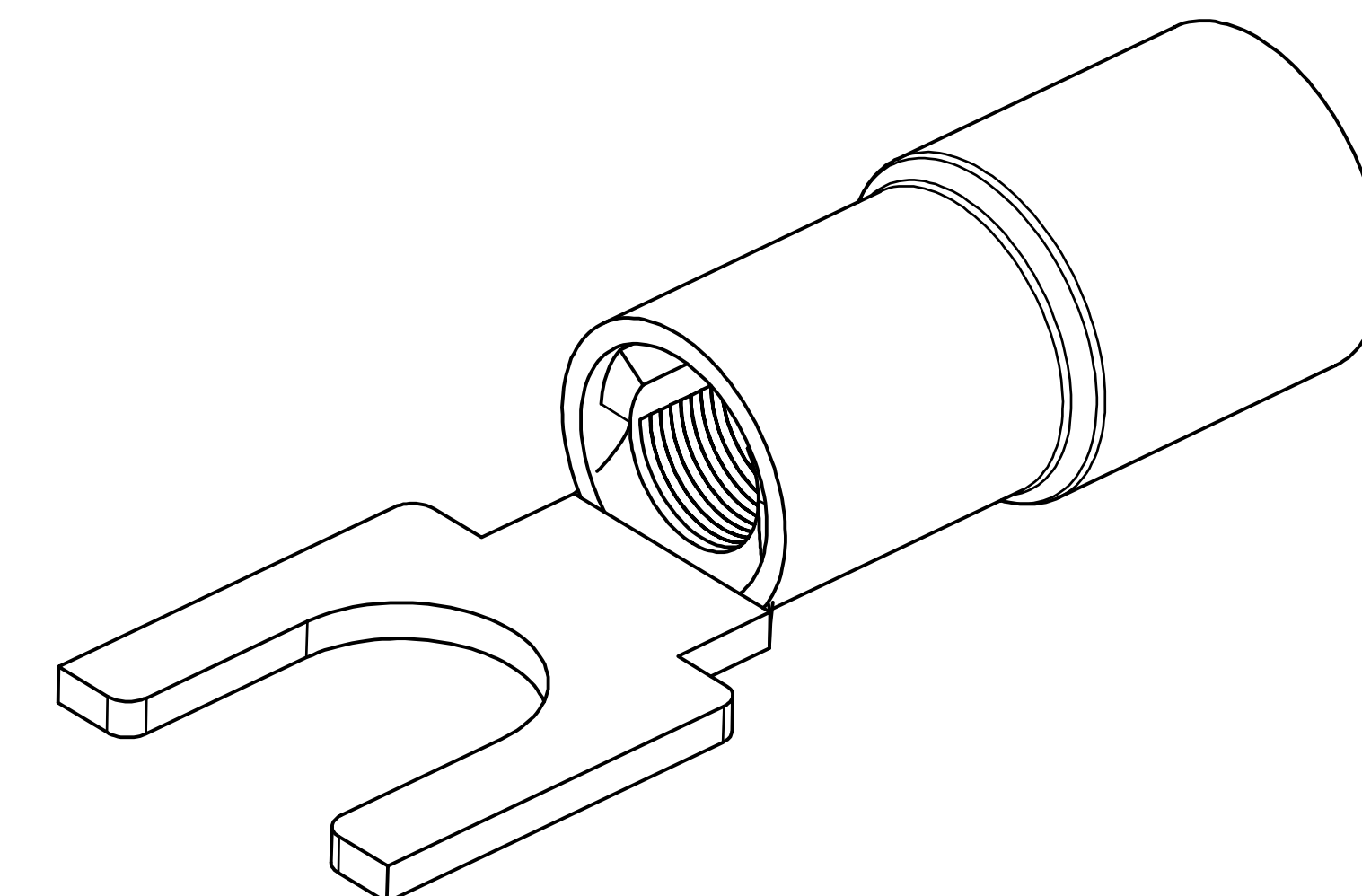
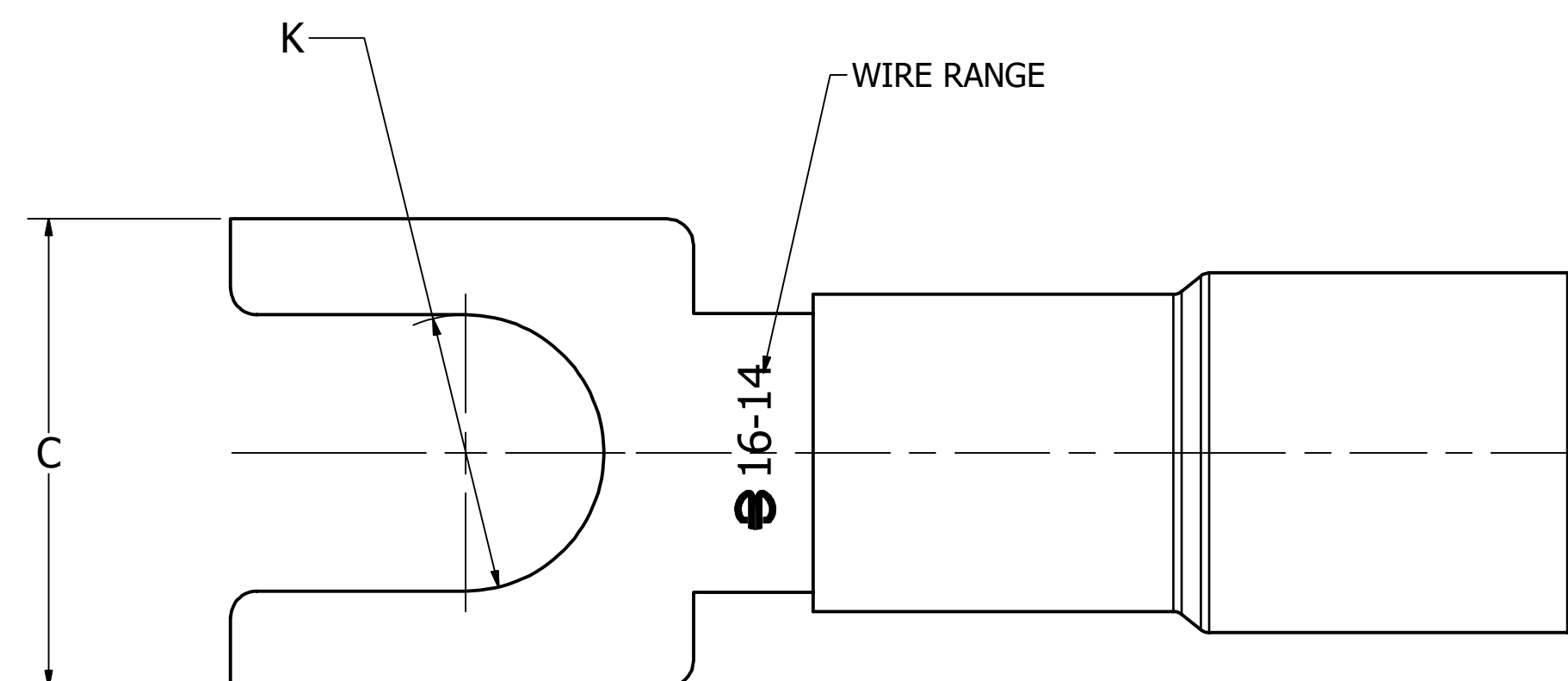
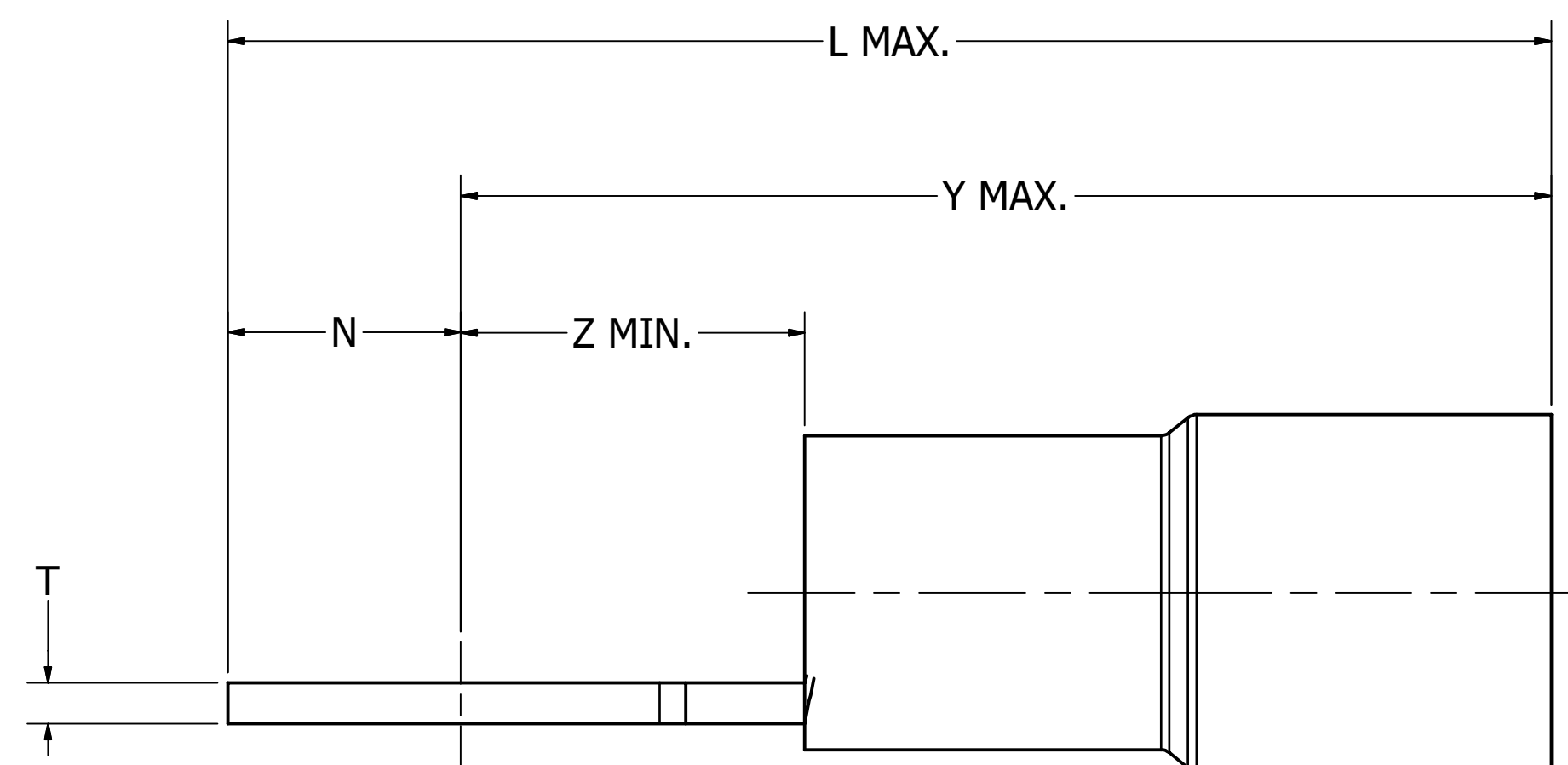

NOTES:

1. TERMINAL: TIN PLATED COPPER
2. INSULATION: NYLON
3. DIMENSIONS IN BRACKETS [] ARE IN MILLIMETERS AND ARE FOR REFERENCE ONLY.
4. DIE SETS ARE LISTED IN BRACKETS [] AFTER THEIR RESPECTIVE TOOLS.
5. WIRE CONNECTOR:
600V MAXIMUM
TEMPERATURE RATING OF INSULATING MATERIAL 105°C
FLAME RATING: UL746C GLOW WIRE TEST

TO ORDER BURNDY® PRODUCTS CALL		HYDENT	
UNITED STATES 1-800-346-4175 (LONDONDERRY, NH)		ITEM NO: --	
CANADA: 1-800-361-6975 (QUEBEC) 1-800-387-6487 (ALL OTHER PROVINCES)		CAT. NO: TYPE TN-BF	
FOR PRODUCT INFO: http://www.burndy.com		DRAWN BY: R.YOGARAJ 10/31/2018	
		CHECKER: V.SAKTHIVEL 10/31/2018	
		DSN APRVL: --	
		MFG APRVL: --	
		QA APRVL: --	
		MKT APRVL: --	
		PROD FAM: --	
		PROJECT #: --	
		DOCUMENT TYPE: SALES	
		REL LEVEL: Released	
		SIZE: D	
		DRAWING NO: 50094182	
		SHEET 1 OF 1	
		REV: A	