

REV	DATE	DESCRIPTION	ECO	BY	C'H'K.
A	10/31/2018	NEW DRAWING CREATION	50189	WP	YR

WIRE SIZE (AWG)	STUD SIZE	CATALOG NUMBER	C		K		L MAX.	N		T ± .01 [± .25]	Y MAX.	Z MIN.	MAX. WIRE INSUL. DIA. ACCOM.	WIRE STRIP LENGTH ± .03 [± .8]	COLOR CODE	INSTALLATION TOOLING (ONE CRIMP)
			MAX.	MIN.	MAX.	MIN.		MAX.	MIN.							
22-18 Str. and Sol.	6	YHSA18K6BF	.28 [7.1]	.22 [5.6]	.15 [3.8]	.14 [3.6]	1.23 [31.2]	.60 [15.2]	.54 [13.7]	.04 [1.0]	.69 [17.5]	.29 [7.4]	.16 [4.2]	7/32" [5.6]	RED	MR22
	8	YHSA18K8BF	.34 [8.6]	.28 [7.1]	.18 [4.5]	.16 [4.1]		.57 [14.5]	.51 [13.0]		.72 [18.3]					
	10	YHSA18K10BF			.23 [5.8]	.19 [4.8]		.51 [13.0]	.45 [11.4]		.78 [19.8]					
16-14 Str. and Sol.	6	YHSA14K6BF	.28 [7.1]	.22 [5.6]	.15 [3.8]	.14 [3.6]	1.21 [30.7]	.58 [14.7]	.52 [13.2]	.04 [1.0]	.69 [17.5]	.27 [6.9]	.18 [4.7]	BLUE	MR22	
	8	YHSA14K8BF	.33 [8.4]	.27 [6.9]	.18 [4.5]	.16 [4.1]	1.23 [31.2]	.57 [14.5]	.51 [13.0]		.72 [18.3]					
	10	YHSA14K10BF	.35 [8.9]	.29 [7.4]	.23 [5.8]	.19 [4.8]		.51 [13.0]	.45 [11.4]		.78 [19.8]					
12-10 Str. and Sol.	6	YHSA10K6BF	.33 [8.4]	.27 [6.9]	.15 [3.8]	.14 [3.6]	1.30 [33.0]	.52 [13.2]	.46 [11.7]	.04 [1.0]	.84 [21.3]	.26 [6.6]	.24 [6.0]	YELLOW	MR22	
	8	YHSA10K8BF	.36 [9.1]	.30 [7.6]	.18 [4.5]	.16 [4.1]		.52 [13.2]	.46 [11.7]		.84 [21.3]					
	10	YHSA10K10BF	.38 [9.7]	.32 [8.1]	.23 [5.8]	.19 [4.8]		.46 [11.7]	.40 [10.2]		.90 [22.9]					

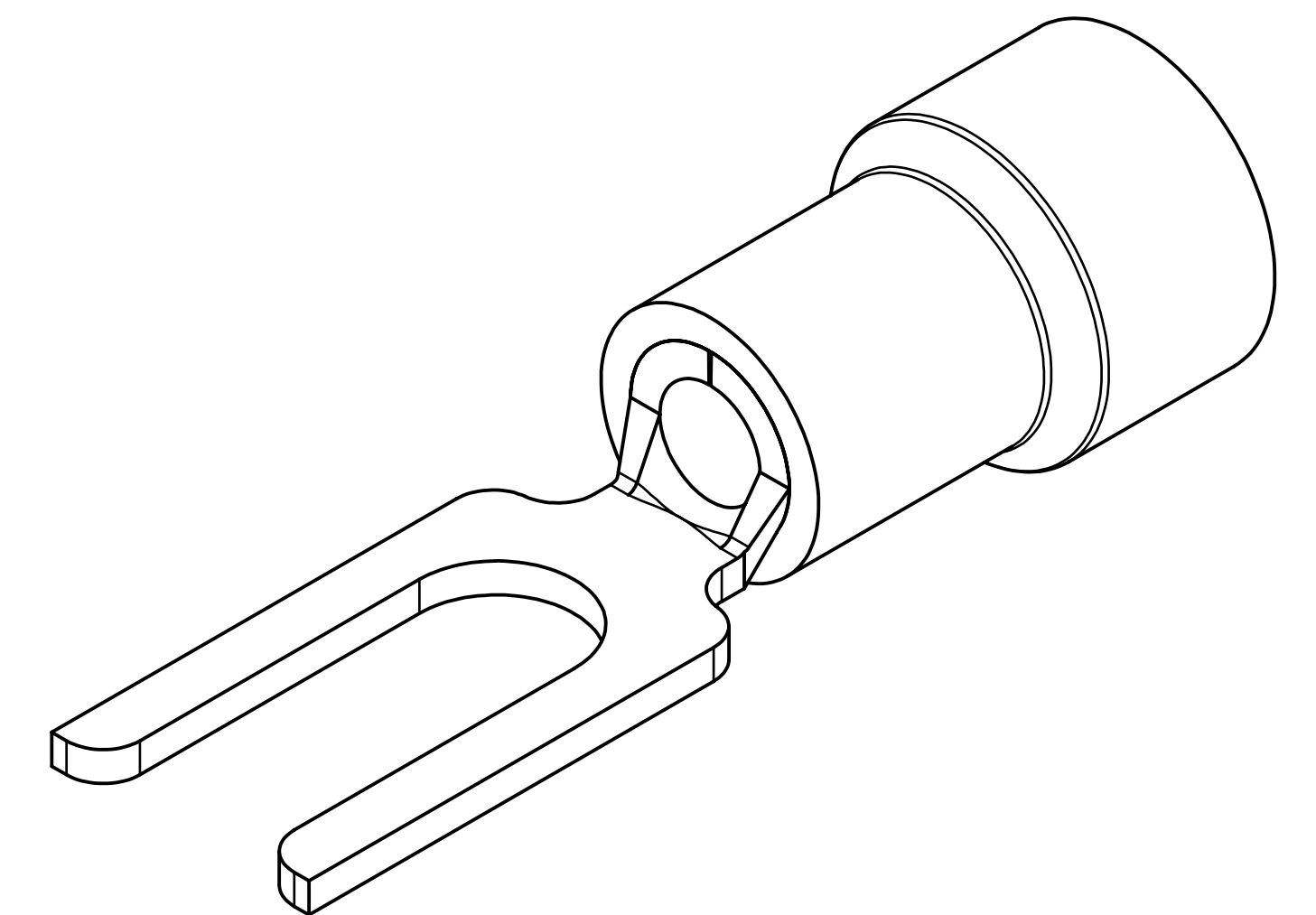
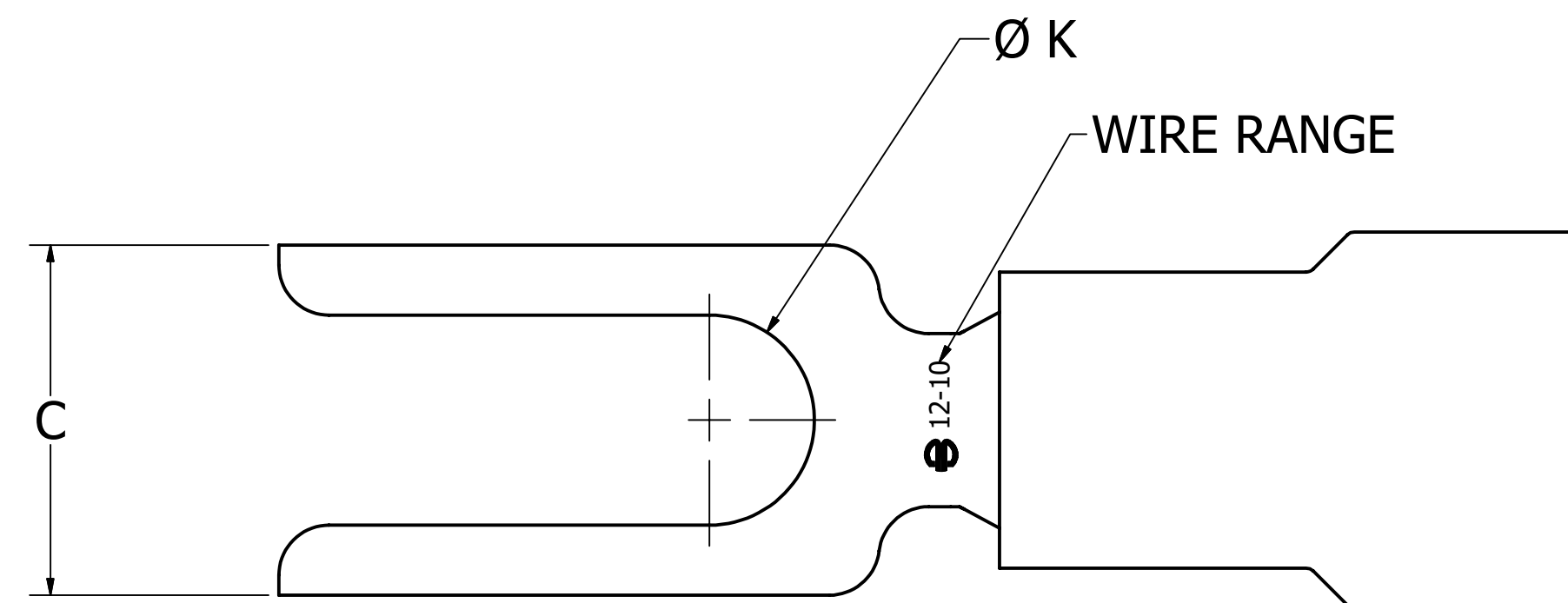
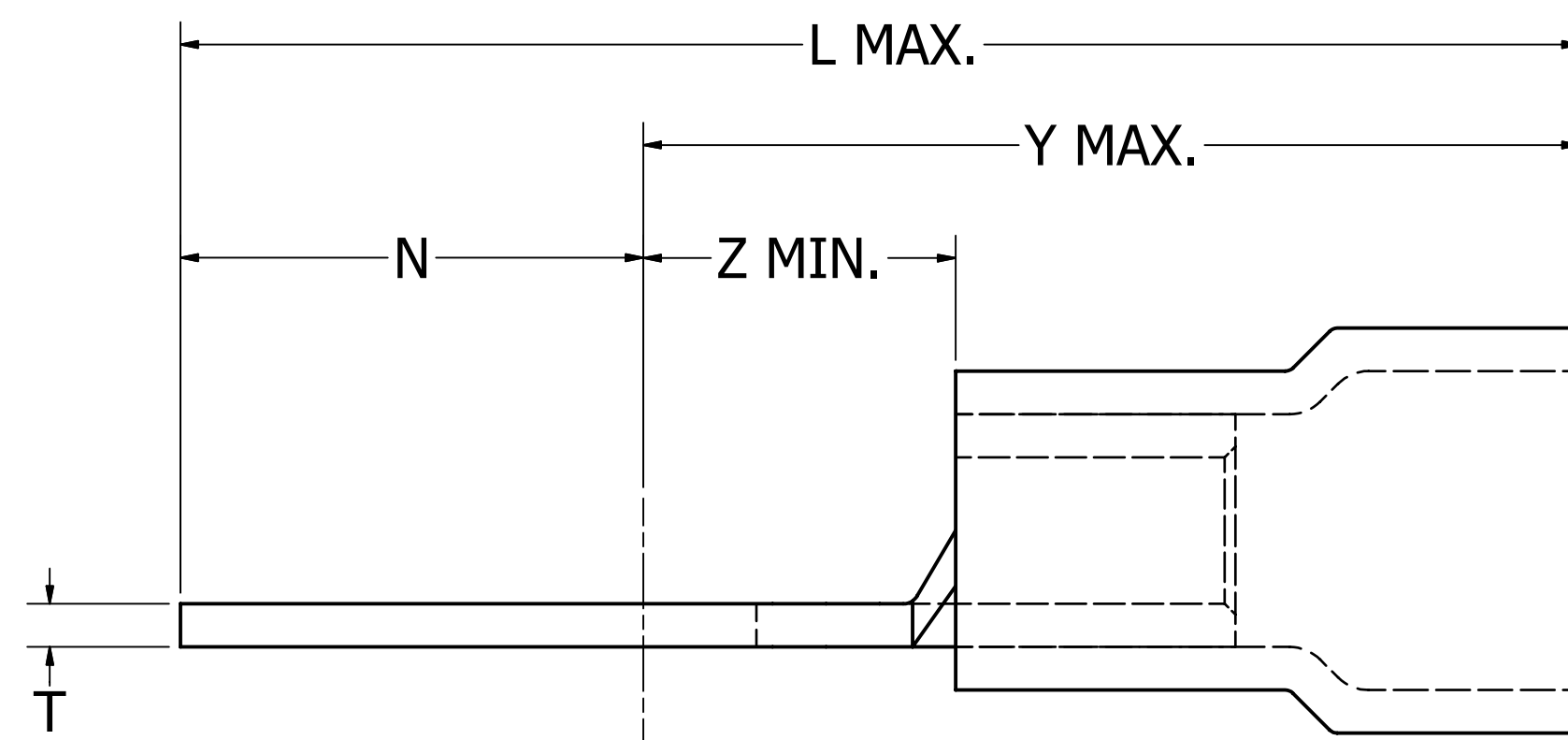

NOTES:

1. TERMINAL: TIN PLATED COPPER
2. INSULATION: HEAT SHRINK
3. DIMENSIONS IN BRACKETS [ ] ARE IN MILLIMETERS AND ARE FOR REFERENCE ONLY.
4. WIRE CONNECTOR:  
 MINIMUM SHRINK TEMPERATURE: 135°C  
 OPERATING TEMPERATURE RANGE: -55°C TO 110°C

TO ORDER BURNDY® PRODUCTS CALL		HYDENT	
UNITED STATES 1-800-346-4175 (LONDONDERRY, NH)		ITEM NO: SEE TABLE	
CANADA: 1-800-361-6975 (QUEBEC) 1-800-387-6487 (ALL OTHER PROVINCES)		CAT. NO: TYPE YHSA-K-BF	
FOR PRODUCT INFO: <a href="http://www.burndy.com">http://www.burndy.com</a>		DRAWN BY: P.WINSON 10/31/2018	
		CHECKER: R.YOGARAJ 10/31/2018	
		DSN APRVL: K.CASTONGUAY 12/12/2018	
		MFG APRVL: --	
		QA APRVL: B.POST 12/06/2018	
		MKT APRVL: M.BAILLY 12/05/2018	
		PROD FAM: --	
		PROJECT #: --	
		SIZE	
		D	
		DRAWING NO	
		50094184	
		REV	
		A	
		SHEET 1 OF 1	