

REV	DATE	DESCRIPTION	ECO	BY	C'H'K.
A	12/06/2018	NEW DRAWING CREATION	50425	YR	VS

WIRE SIZE (AWG)	STUD SIZE	CATALOG NUMBER	BULK CATALOG NUMBER	C		K		L MAX.	N		T ±.01 [±.25]	Y MAX.	Z MIN.	WIRE STRIP LENGTH ±.03 [±.8]	INSTALLATION TOOLING (ONE CRIMP)
				MAX.	MIN.	MAX.	MIN.		MAX.	MIN.					
22-18 Str. and Sol.	6	YAV18T19FBOX	YAV18T19F	.31 [7.8]	.30 [7.5]	.15 [3.8]	.14 [3.6]	.84 [21.2]	.26 [6.6]	.24 [6.1]	.03 [0.9]	.60 [15.1]	.21 [5.3]	9/32" [7.1]	Y6NCB [J1022NC5], Y6NCP1 [J1022NC5], Y1022, Y8MRB1, Y81KFT, Y81KFTMBH, PAT81KFT18V, MRE1022B, Y122CMR ##  ## - Y122CMR only to be used for YAV10HF
20-18 Str. and Sol.	10	YAV18T21FBOX	YAV18T21F	.38 [9.7]	.35 [8.9]	.23 [5.8]	.19 [4.8]								
20-14 Str. and Sol.	6	YAV14T32FBOX	YAV14T32F	.31 [7.8]	.29 [7.3]	.15 [3.8]	.14 [3.6]	.83 [21.2]	.24 [6.2]	.22 [5.7]	.05 [1.2]	.61 [15.5]	.23 [5.9]		
	10	YAV14T34FBOX	YAV14T34F	.38 [9.7]	.35 [8.9]	.23 [5.8]	.19 [4.8]	.81 [20.6]	.23 [5.8]	.21 [5.3]	.04 [0.9]	.60 [15.3]			
12-10 Str. and Sol.	1/4	YAV10T23FBOX	YAV10T23F	.48 [12.3]	.45 [11.5]	.28 [7.1]	.26 [6.6]	1.03 [26.2]	.26 [6.6]	.24 [6.1]	.05 [1.2]	.79 [20.1]	.30 [7.7]	7/16" [11.1]	

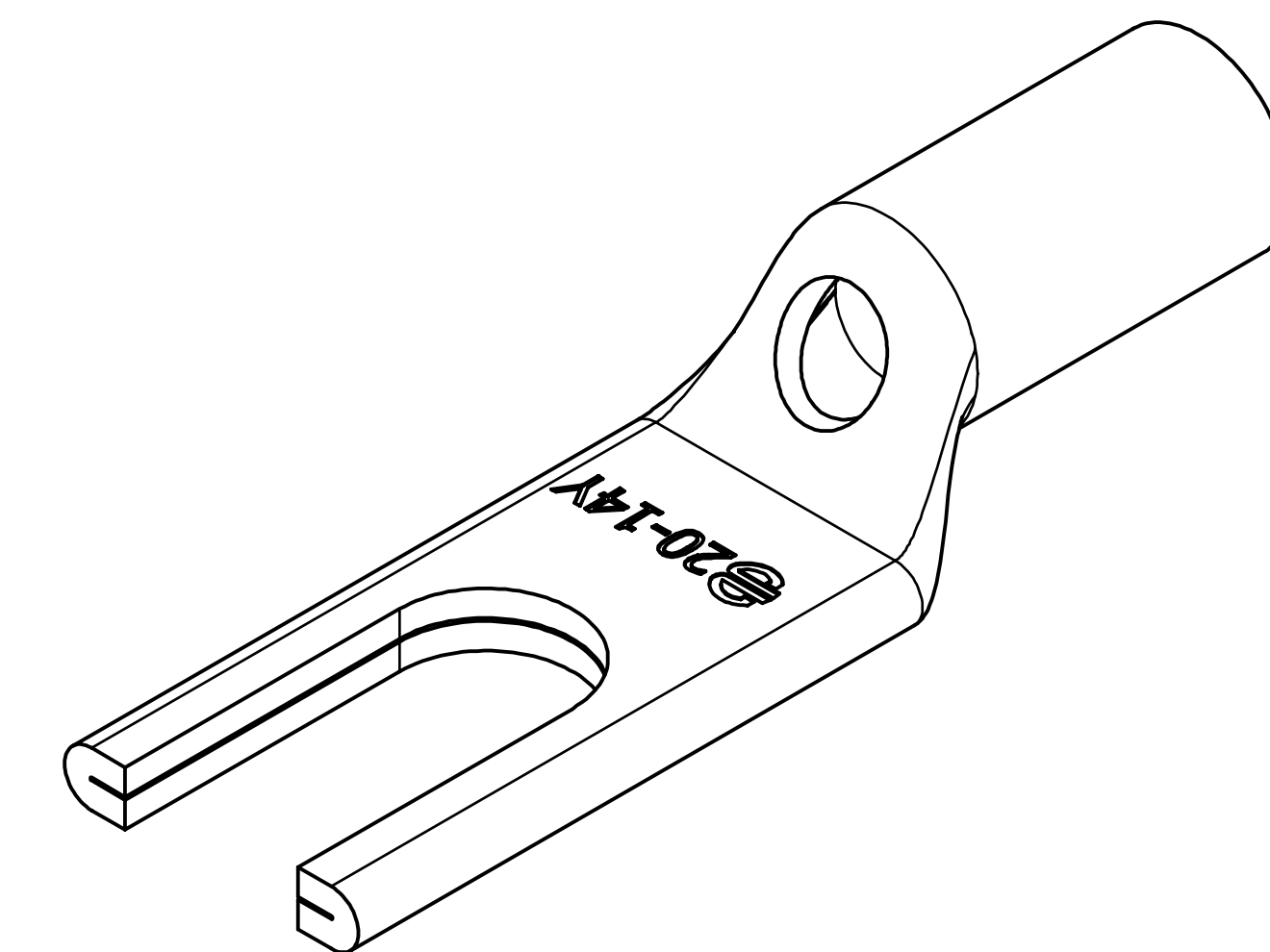
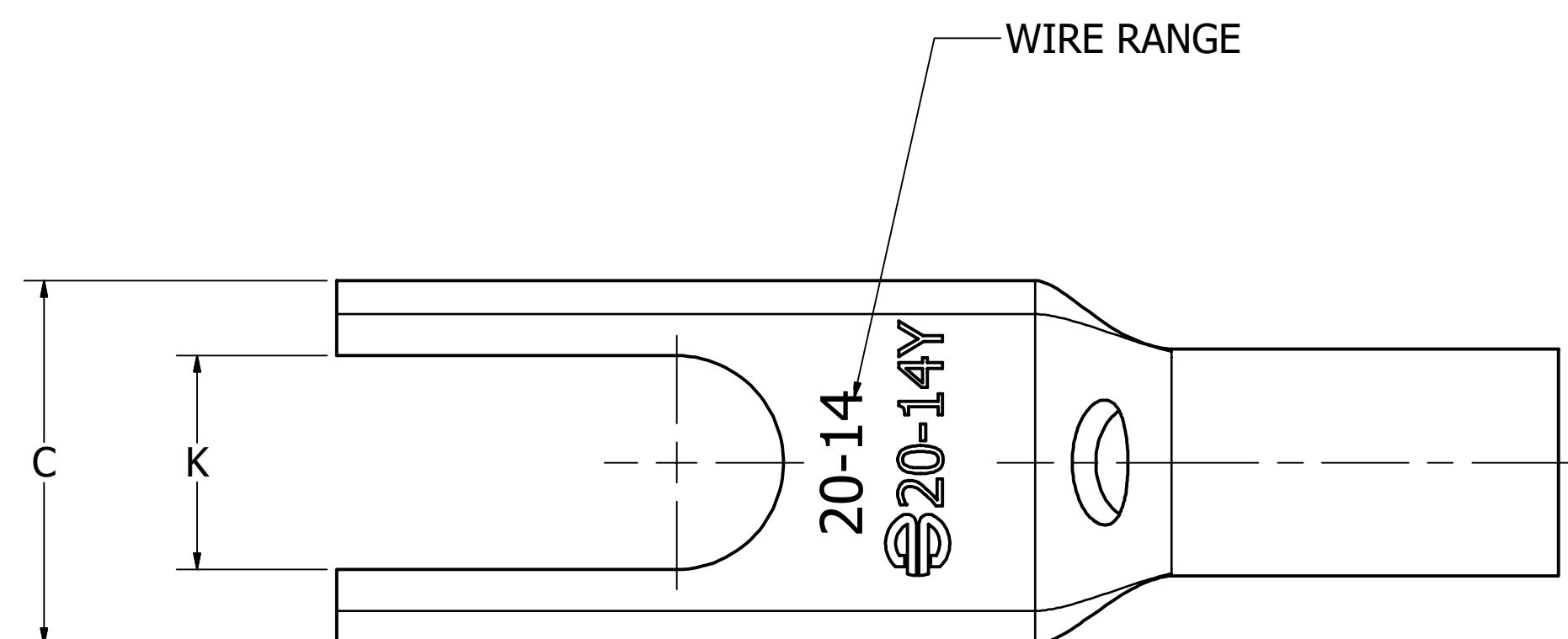
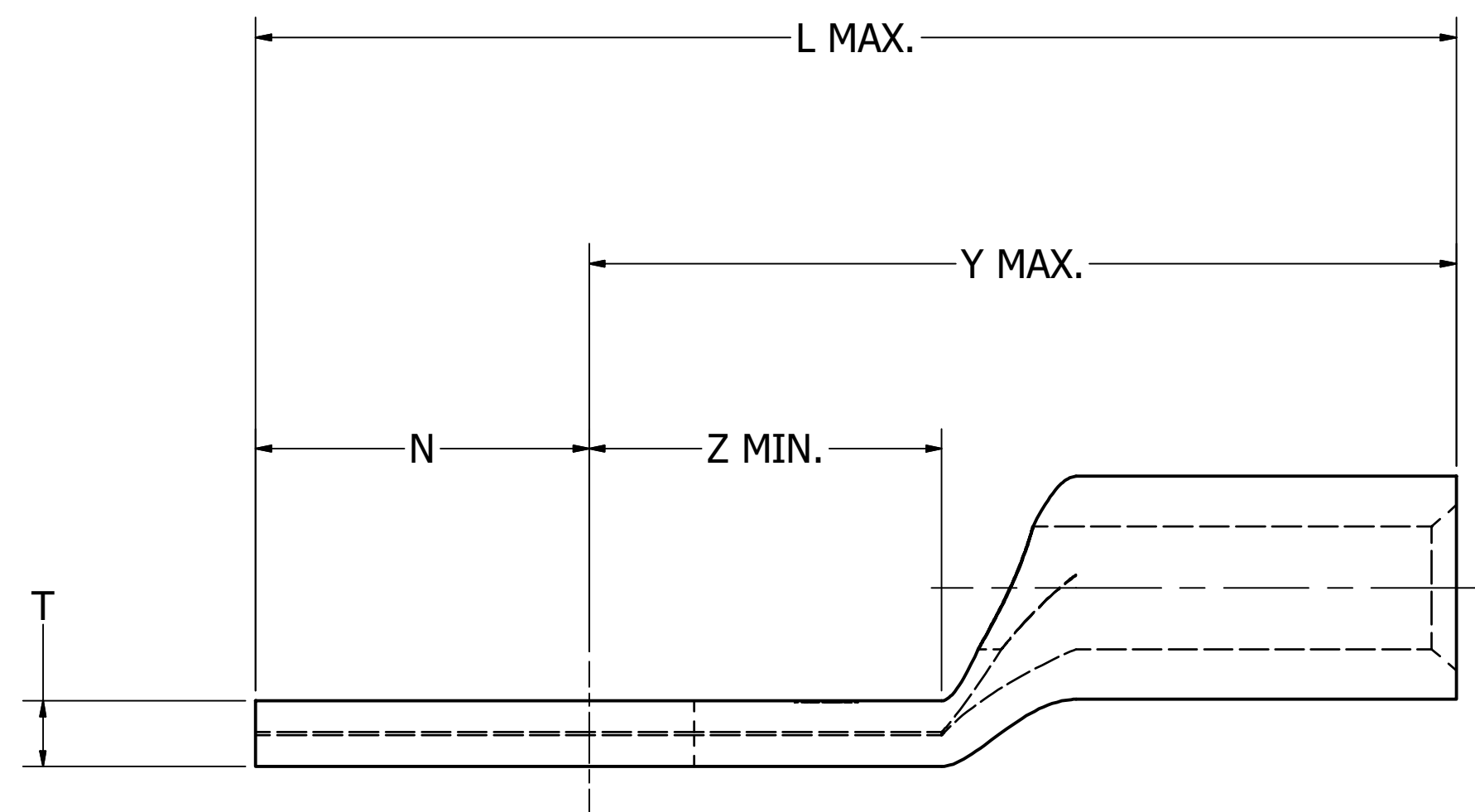

**NOTES:**

1. TERMINAL: TIN PLATED COPPER
2. DIMENSIONS IN BRACKETS [ ] ARE IN MILLIMETERS AND ARE FOR REFERENCE ONLY.
3. DIE SETS ARE LISTED IN BRACKETS [ ] AFTER THEIR RESPECTIVE TOOLS.
4. UL LISTED & CSA CERTIFIED WIRE CONNECTORS PER UL486A/B (FILE E9498) & CSA C22.2 NO.65 REQUIREMENTS (FILE 42862)
5. DISCONTINUED TOOLS: Y6NCP, Y10MRS, Y10MRPA, EMR20, PATMD1022LI  
CONTACT TECH SERVICE FOR INFORMATION ABOUT APPROVED APPLICATIONS (1-800-451-4956)

TO ORDER BURNDY® PRODUCTS CALL		HYLUG	
UNITED STATES 1-800-346-4175 (LONDONDERRY, NH)		ITEM NO: N/A	
CANADA: 1-800-361-6975 (QUEBEC) 1-800-387-6487 (ALL OTHER PROVINCES)		CAT. NO: TYPE YAV-T-F	
FOR PRODUCT INFO: <a href="http://www.burndy.com">http://www.burndy.com</a>		DRAWN BY: R.YOGARAJ 12/06/2018	
		CHECKER: V.SAKTHIVEL 12/06/2018	
		DSN APRVL: --	
		MFG APRVL: --	
		QA APRVL: --	
		MKT APRVL: --	
		PROD FAM: --	
		PROJECT #: --	
		SIZE	
		D	
		DRAWING NO	
		50094187	
		SHEET 1 OF 1	
		REV	
		A	