

REV	DATE	DESCRIPTION	ECO	BY	C'H'K.
A	3/8/2019	NEW DRAWING CREATION	50985	PP	WP

WIRE SIZE (AWG)	CATALOG NUMBER	BULK CATALOG NUMBER	NEMA Tab Size	LENGTH (L)	WIDTH (W)	WIRE STRIP LENGTH ±.03 [±.8]	COLOR CODE	INSTALLATION TOOLING (ONE CRIMP)
22-16 Str. and Sol.	QN18F11X02D	QN18F11X02B	.11 X .02	.77 [19.6]	.11 [2.8]	3/8" [9.5]	RED	MRE1022NV, Y1022, Y10D
	QN18F18X02D	QN18F18X02B	.19 X .02	.79 [20.1]	.19 [4.7]			
	QN18F25X03D	QN18F25X03B	.25 X .03	.87 [22.1]	.25 [6.4]			
16-14 Str. and Sol.	QN14F11X02D	QN14F11X02B	.11 X .02	.77 [19.6]	.11 [2.8]		BLUE	
	QN14F18X02D	QN14F18X02B	.19 X .02	.79 [20.1]	.19 [4.7]			
	QN14F25X03D	QN14F25X03B	.25 X .03	.87 [22.1]	.25 [6.4]			
12-10 Str. and Sol.	QN10F18X02D*	QN10F18X02B	.19 X .02	.84 [21.3]	.19 [4.7]		YELLOW	
	QN10F25X03D	QN10F25X03B	.25 X .03	.95 [24.1]	.25 [6.4]			

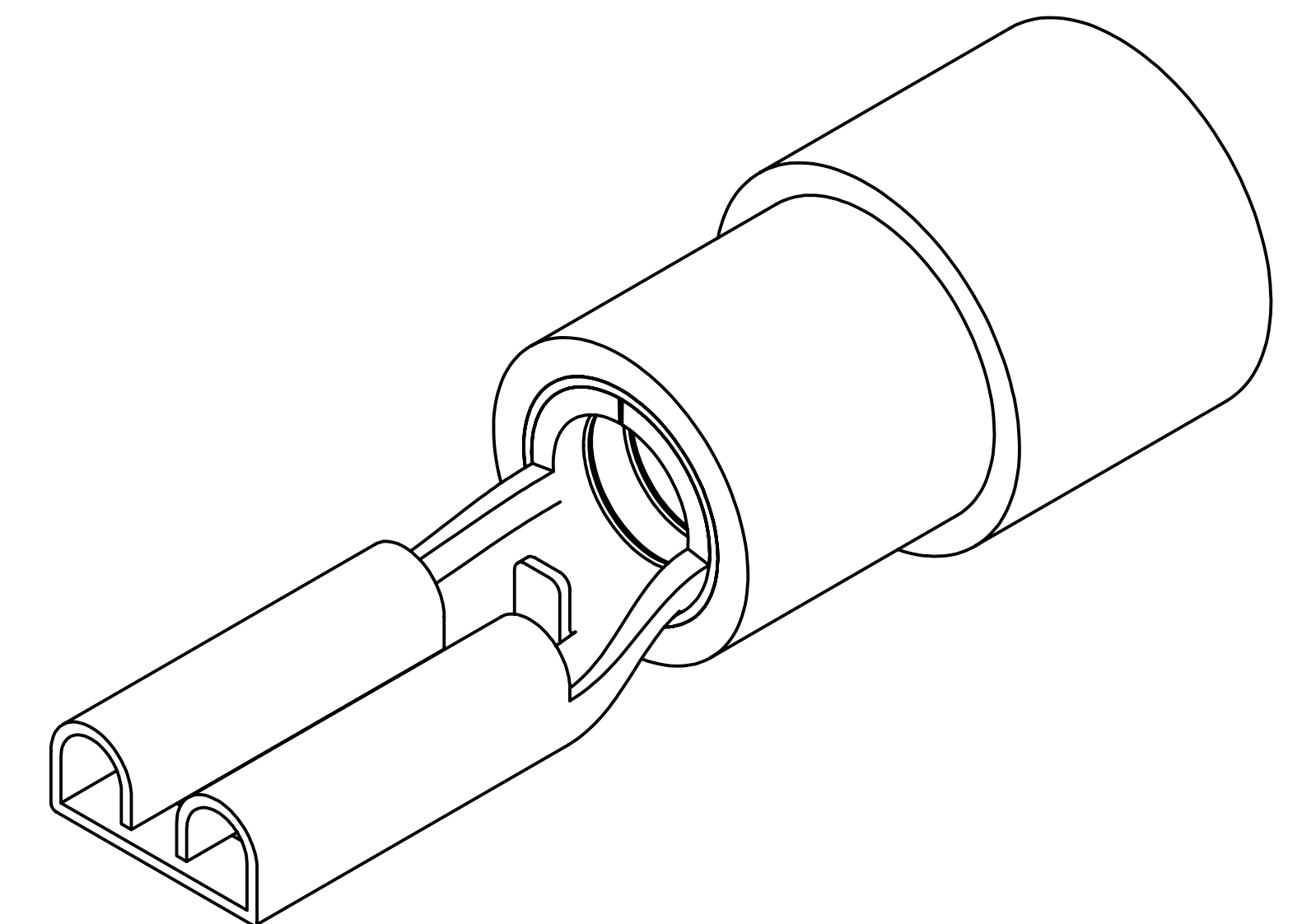
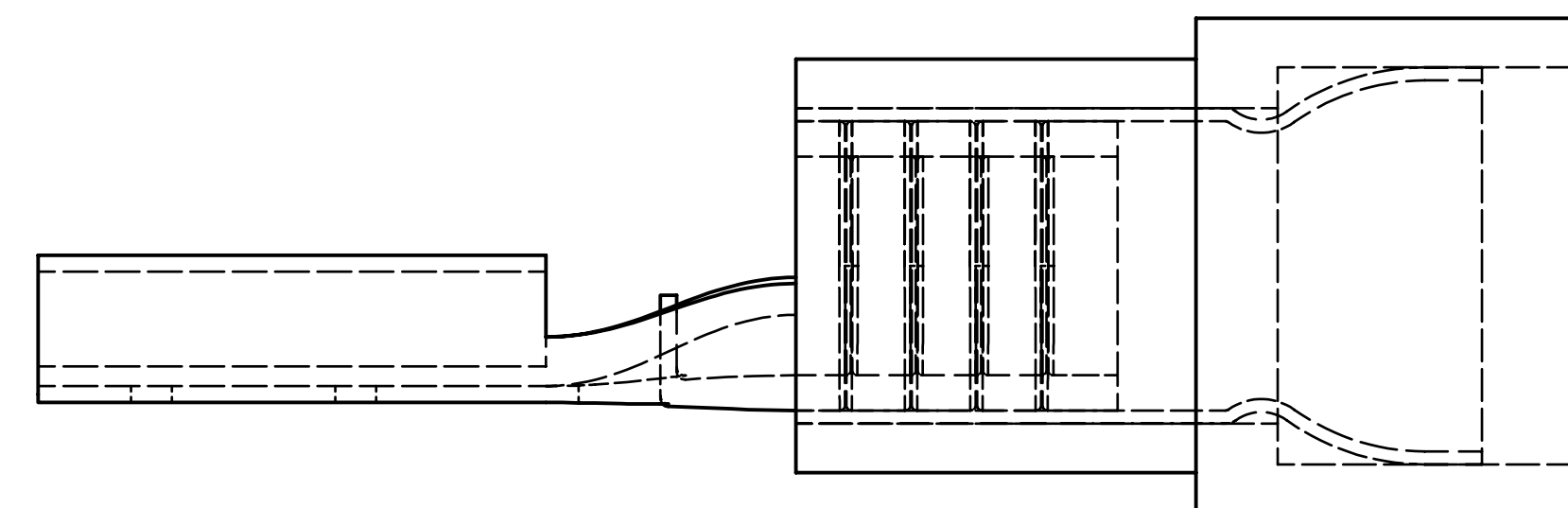
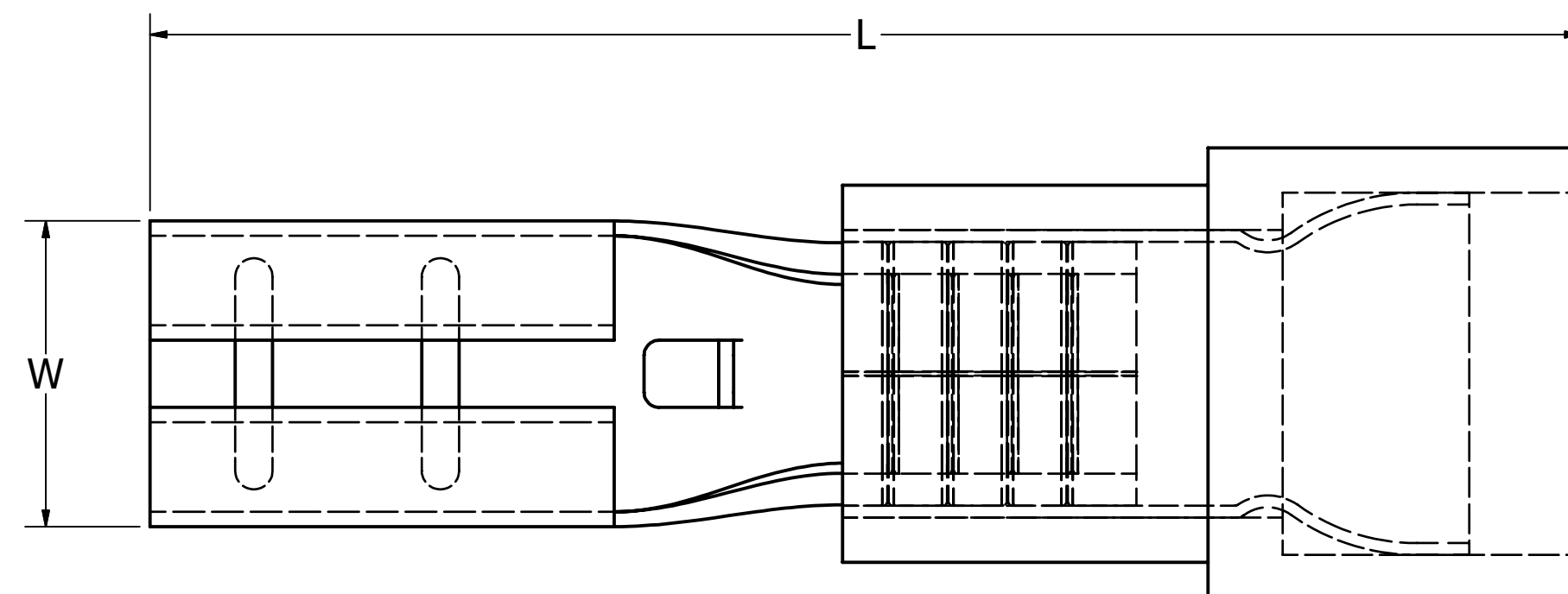

NOTES:

1. TERMINAL: TIN PLATED BRASS
2. INSULATION: NYLON
3. DIMENSIONS IN BRACKETS [] ARE IN MILLIMETERS AND ARE FOR REFERENCE ONLY.
4. cULus LISTED ELECTRICAL QUICK-CONNECT TERMINALS PER UL310 (FILE E79563) & CSA C22.2 NO. 153 REQUIREMENTS.
5. WIRE CONNECTOR:

300V MAXIMUM

TEMPERATURE RATING OF INSULATING MATERIAL 105°C

FLAME RATING: UL94 V-2

6. ITEMS WITH CATALOG NUMBERS FOLLOWED BY ASTERISKS (*) ARE NOT cULus LISTED.

TO ORDER BURNDY® PRODUCTS CALL

UNITED STATES
1-800-346-4175 (LONDONDERRY, NH)

CANADA:
1-800-361-6975 (QUEBEC)
1-800-387-6487 (ALL OTHER PROVINCES)

FOR PRODUCT INFO: <http://www.burndy.com>

FINGRIP

ITEM NO: N/A		
CAT. NO: TYPE QN-F		
DRAWN BY: P.PRASANTH	2/22/2019	
CHECKER: A.FITZGERALD	3/13/2019	
DSN APRVL: K.CASTONGUAY	3/13/2019	
MFG APRVL: --		
QA APRVL: B.ELLIOTT	3/12/2019	
MKT APRVL: M.BAILLY	3/13/2019	
PROJECT #: --	SIZE	DRAWING NO
DOCUMENT TYPE: SALES	D	50094210
REL LEVEL: Released		SHEET 1 OF 1

REV

A