

REV	DATE	DESCRIPTION	ECO	BY	C'H'K.
A	3/11/2019	CREATION NEW DRAWING	50987	PP	WP

WIRE SIZE (AWG)	CATALOG NUMBER	BULK CATALOG NUMBER	NEMA Tab Size	LENGTH (L)	WIDTH (W)	WIRE STRIP LENGTH ± .03 [± .8]	COLOR CODE	INSTALLATION TOOLING (ONE CRIMP)
22-18 Str. and Sol.	FQN18M18X02D*	-	.19 X .02	.88 [22.4]	.19 [4.7]	3/8" [9.5]	RED	MRE1022NV, Y1022, Y10D
	FQN18M25X03D	FQN18M25X03B	.25 X .03	.80 [20.3]	.25 [6.4]			
16-14 Str. and Sol.	FQN14M18X02D*	-	.19 X .02	.19 [4.7]			BLUE	
	FQN14M25X03D	FQN14M25X03B		.88 [22.4]	.25 [6.4]	YELLOW		
12-10 Str. and Sol.	FQN10M25X03D	FQN10M25X03B	.25 X .03	.96 [24.4]				

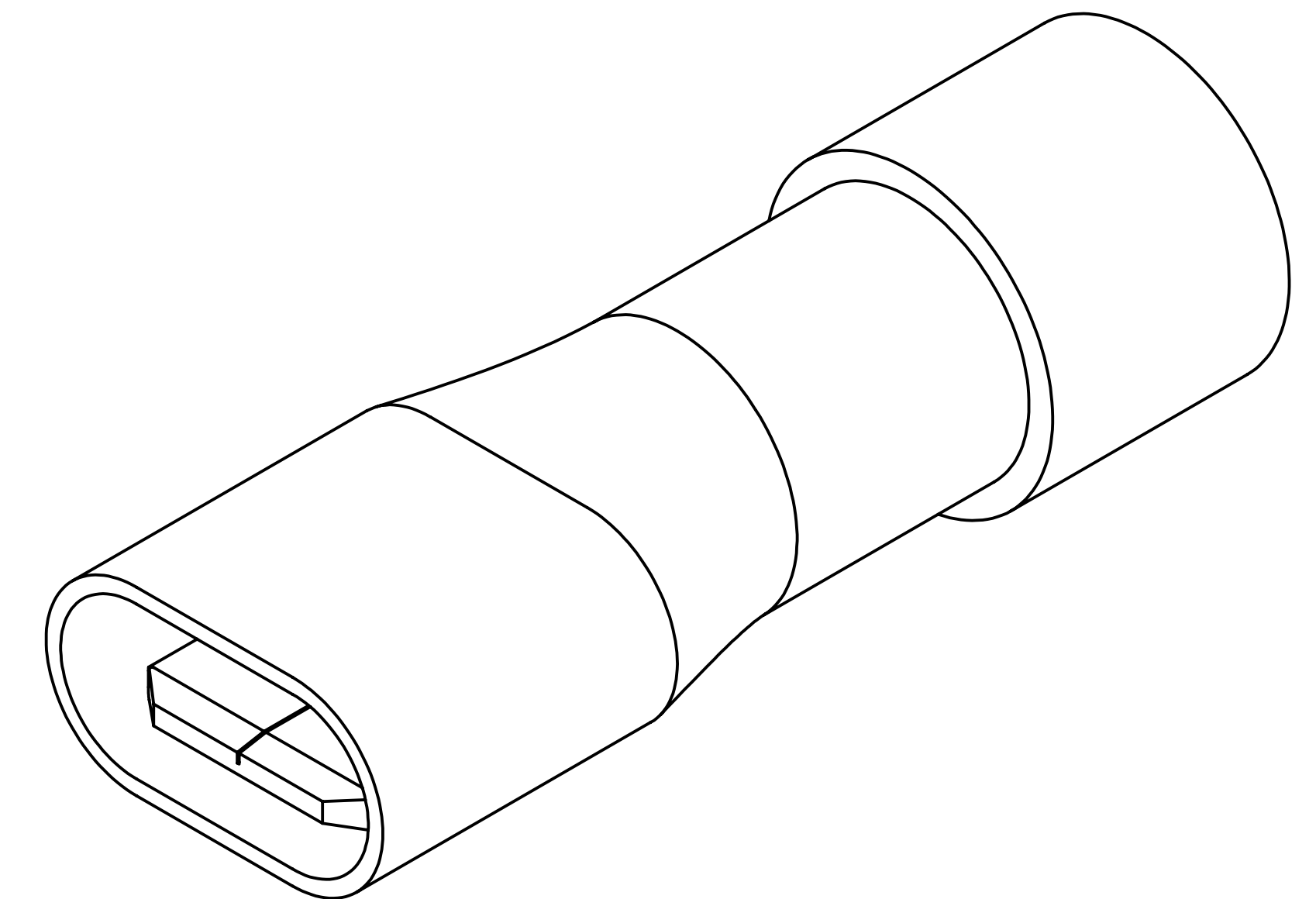
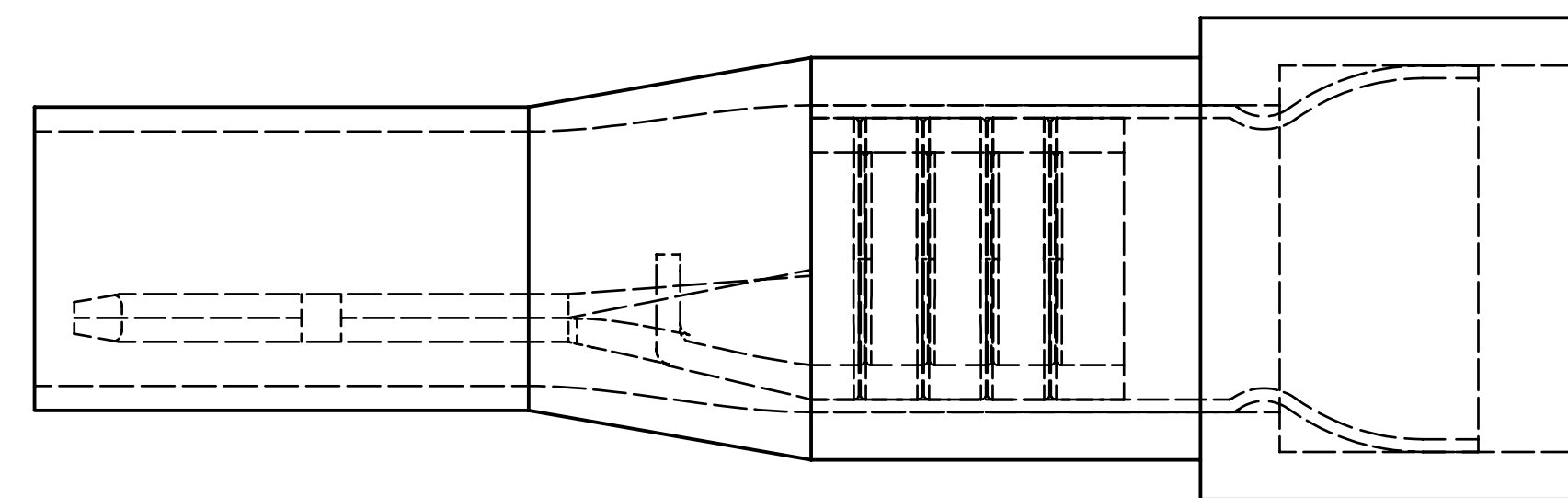
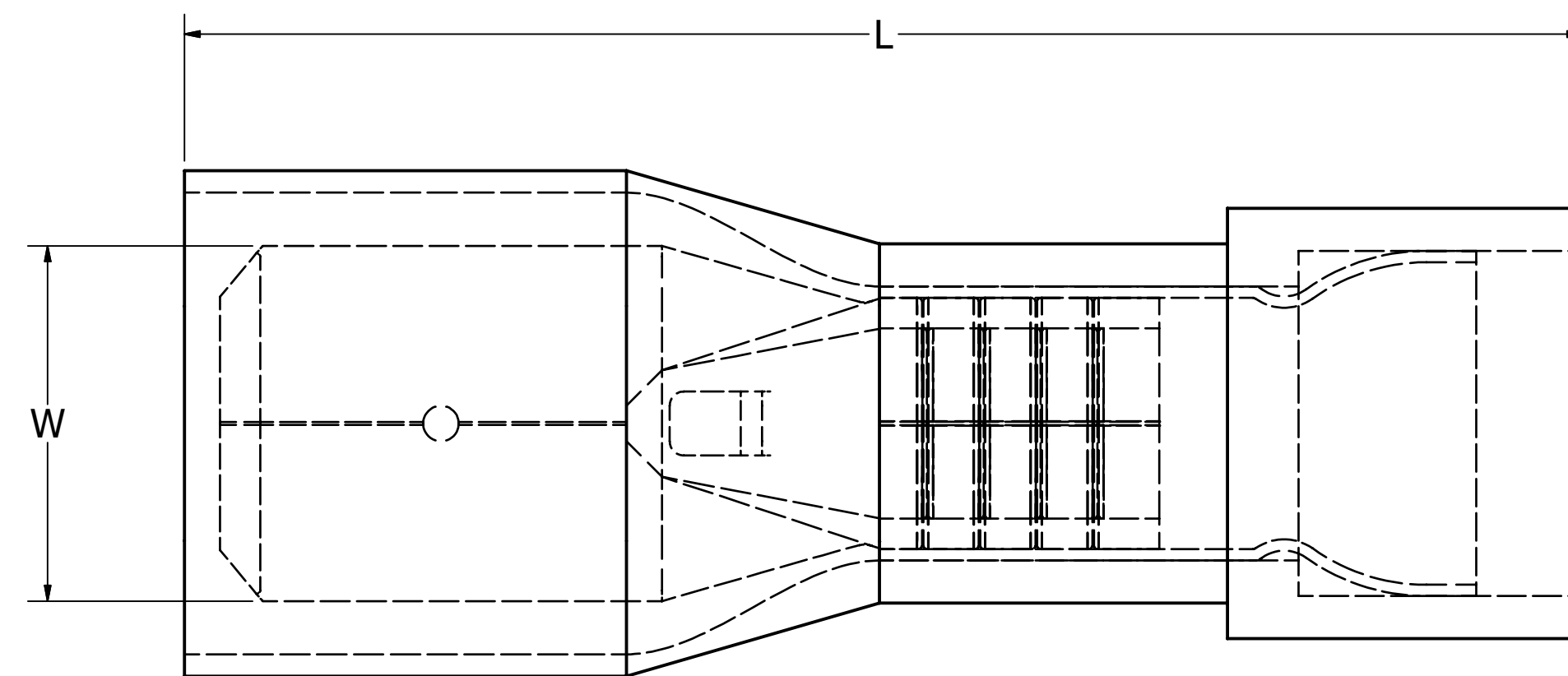

NOTES:

1. TERMINAL: TIN PLATED BRASS
2. INSULATION: NYLON
3. DIMENSIONS IN BRACKETS [] ARE IN MILLIMETERS AND ARE FOR REFERENCE ONLY.
4. cULus LISTED ELECTRICAL QUICK-CONNECT TERMINALS PER UL310 (FILE E79563) & CSA C22.2 NO. 153 REQUIREMENTS.
5. WIRE CONNECTOR:
300V MAXIMUM
TEMPERATURE RATING OF INSULATING MATERIAL 105°C
FLAME RATING: UL94 V-2
6. ITEMS WITH CATALOG NUMBERS FOLLOWED BY ASTERISKS (*) ARE NOT cULus LISTED.

TO ORDER BURNDY® PRODUCTS CALL		FINGRIP	
UNITED STATES 1-800-346-4175 (LONDONDERRY, NH)		ITEM NO: N/A	
CANADA: 1-800-361-6975 (QUEBEC) 1-800-387-6487 (ALL OTHER PROVINCES)		CAT. NO: TYPE FQN-M	
FOR PRODUCT INFO: http://www.burndy.com		DRAWN BY: P.PRASANTH 2/22/2019	
		CHECKER: --	
		DSN APRVL: K.CASTONGUAY 3/26/2019	
		MFG APRVL: --	
		QA APRVL: B.ELLIOTT 3/18/2019	
		MKT APRVL: M.BAILLY 3/16/2019	
		PROD FAM: --	
		PROJECT #: --	
		SIZE	
		D	
		DRAWING NO	
		50094211	
		REV	
		A	
		SHEET 1 OF 1	