

REV	DATE	DESCRIPTION	ECO	BY	C'H'K.
A	09/26/2018	NEW DRAWING	49975	JL	KC

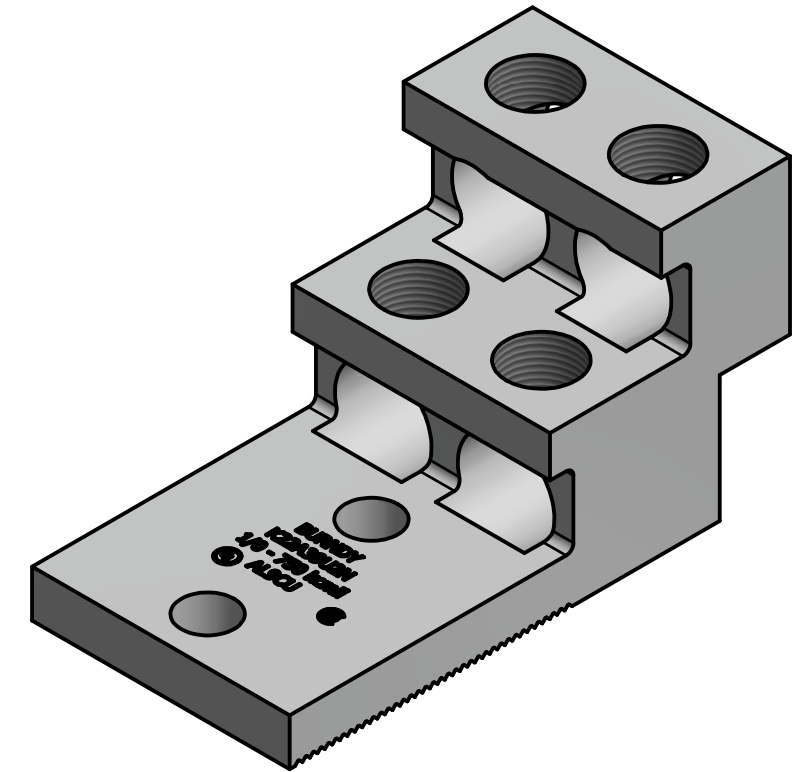
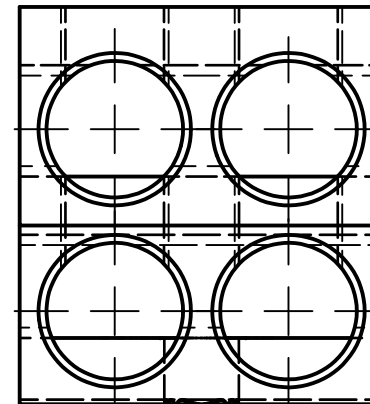
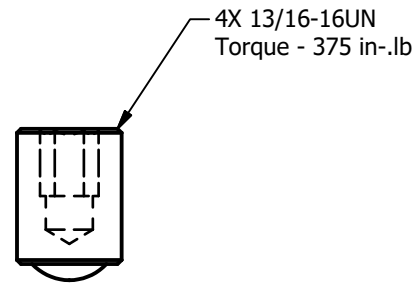
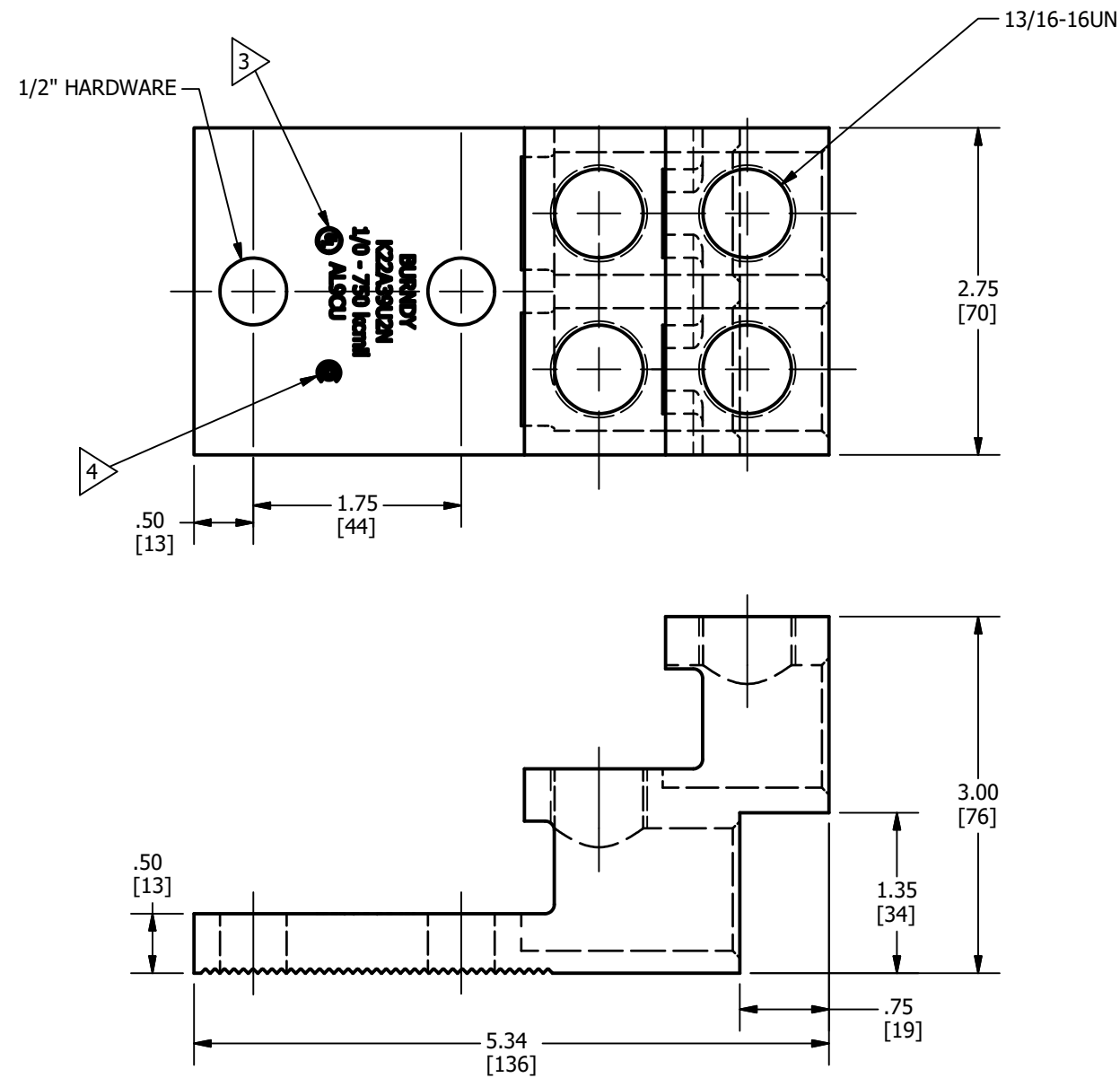

NOTES:

- METERAIL: BODY - ALUMINUM
SCREW - ALUMINUM
- FINISH-BODY: TIN - PLATED
SCREW: TIN - PLATED
- CONECTORS ARE UL LISTED TO UL486A - 486B FOR ALUMINUM AND
COPPER CONDUCTORS AT 90°C.
- CONNECTORS ARE CSA CERTIFIED TO C22.2. NO. 65 FOR
INDICATED CONDUCTORS RANGE.
- NOT RECOMMENDED FOR USE IN HIGHLY CORROSIVE ENVIROMMENT.
- DIMENSIONS IN BRACKETS [] ARE IN MILLIMETERS ROUNDED OFF TO THE
NEAREST MILLIMETER, UNLESS OTHERWISE SPECIFIED AND ARE FOR REFERENCE ONLY.

TO ORDER BURNDY® PRODUCTS CALL UNITED STATES 1-800-346-4175 (LONDONDERRY, NH) CANADA: 1-800-361-6975 (QUEBEC) 1-800-387-6487 (ALL OTHER PROVINCES) FOR PRODUCT INFO: http://www.burndy.com	UNIVERSAL TERMINAL	
	ITEM NO: 50041407	
CAT. NO: K22A39U2N		
DRAWN BY: JL BERGERON 9/26/2018		
CHECKER: K.CASTONGUAY 9/26/2018		
DSN APRVL: T.REYNOLDS 10/15/2018		
MFG APRVL: --		
QA APRVL: B.POST		
MKT APRVL: M.BAILLY 10/15/2018		
PROD FAM: --	DRAWING NO	REV
PROJECT #: --	SIZE	50094866
DOCUMENT TYPE: SALES	B	A
REL LEVEL: Released	SHEET 1 OF 1	