

REV	DATE	DESCRIPTION	ECO	BY	CHK.
B	03/12/2020	DEVELOP A COMPLETE SET OF PRODUCTION DRAWINGS AND 3D MODELS FOR GL2929CG13. LINK ALL DRAWINGS IN AGILE. SALES DRAWING ATTACHED FOR REFERENCE ALONG WITH SAP BOM'S.	53193	MK	NJS

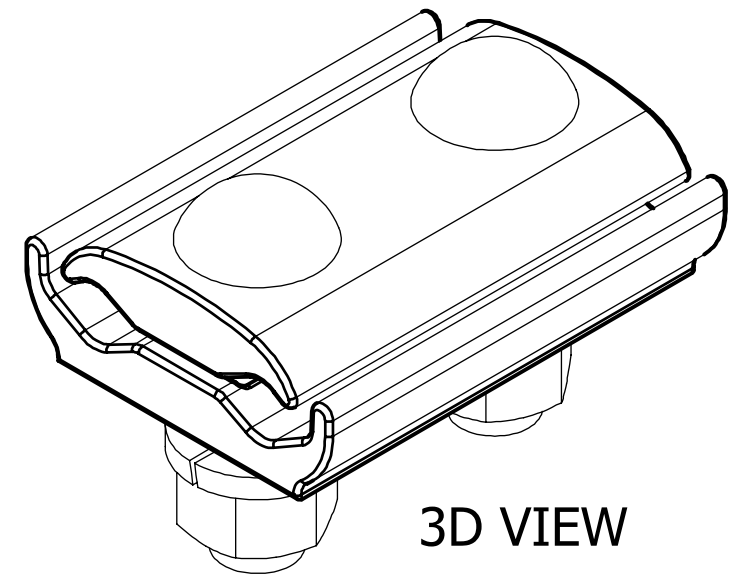
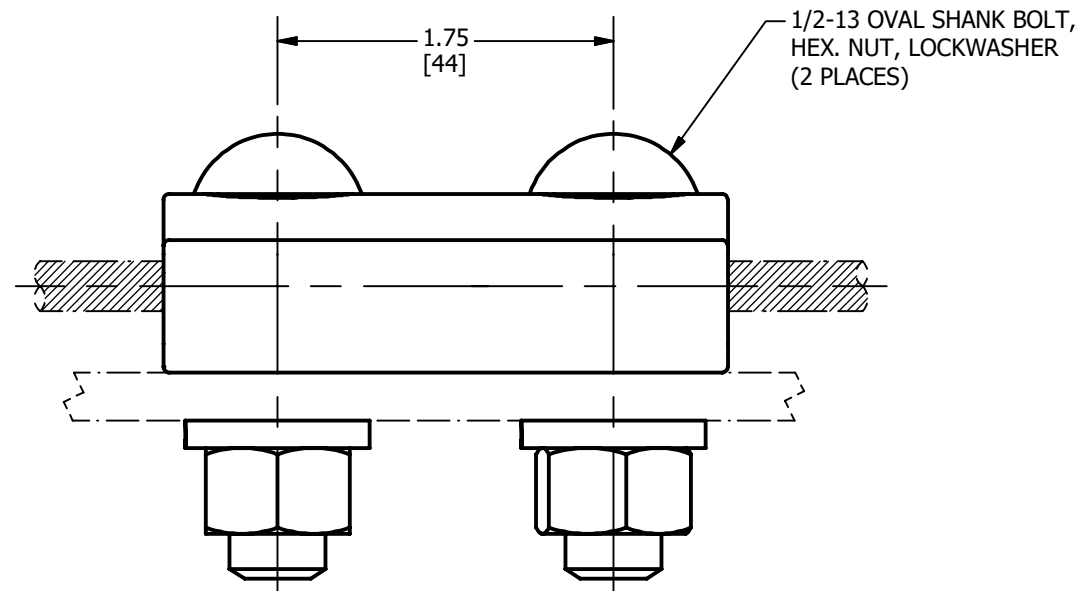
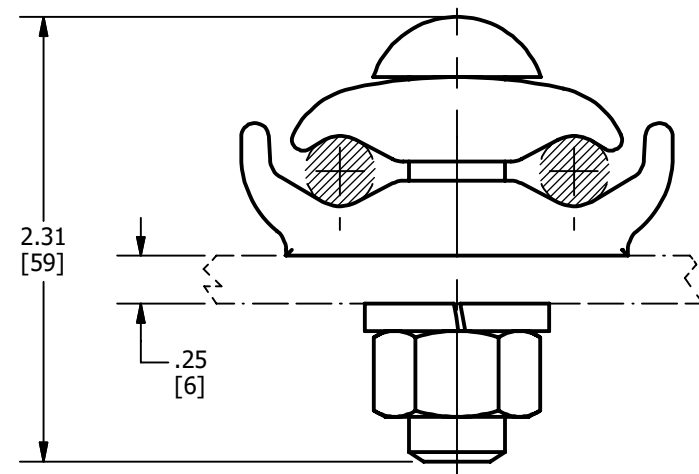
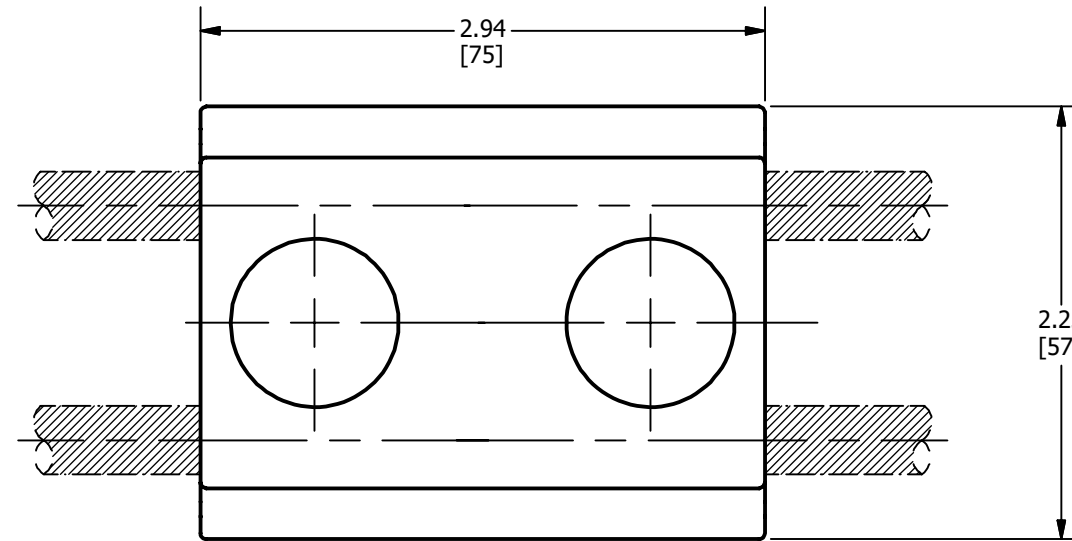

NOTES:

- MATERIAL : TIN-PLATED CAST COPPER ALLOY
HARDWARE: SILICON BRONZE
- ACCOMMODATES:
CONDUCTOR: 2/0 SOL. (.365 DIA.) TO 250 kcmil (.578 DIA.)
BUS BAR: .25 THICK MAX.
- FOR INSTALLATION, TIGHTEN EVENLY TO 360 IN-LB.
- DIMENSIONS IN BRACKETS [] ARE IN MILLIMETERS ROUNDED OFF TO THE NEAREST MILLIMETER, UNLESS OTHERWISE NOTED, AND ARE FOR REFERENCE ONLY.

TO ORDER BURNDY® PRODUCTS CALL		GROUND CLAMP															
UNITED STATES 1-800-346-4175 (LONDONDERRY, NH)		ITEM NO: 27013577															
CANADA: 1-800-361-6975 (QUEBEC) 1-800-387-6487 (ALL OTHER PROVINCES)		CAT. NO: GL2929CG13															
FOR PRODUCT INFO: http://www.burndy.com		<table border="1"> <tr> <td>DRAWN BY: B.PARTHIBAN</td> <td>08/20/2019</td> <td rowspan="5" style="text-align: center;">BURNDY</td> </tr> <tr> <td>CHECKER: L.TROMBLEY</td> <td>04/29/2020</td> </tr> <tr> <td>DSN APRVL: L.TROMBLEY</td> <td>04/29/2020</td> </tr> <tr> <td>MFG APRVL: T.WAWRZYNIAK</td> <td>04/25/2020</td> </tr> <tr> <td>QA APRVL: J.BRODEUR</td> <td>04/25/2020</td> </tr> <tr> <td>MKT APRVL: K.ROBICHEAU</td> <td>08/29/2019</td> <td></td> </tr> </table>		DRAWN BY: B.PARTHIBAN	08/20/2019	BURNDY	CHECKER: L.TROMBLEY	04/29/2020	DSN APRVL: L.TROMBLEY	04/29/2020	MFG APRVL: T.WAWRZYNIAK	04/25/2020	QA APRVL: J.BRODEUR	04/25/2020	MKT APRVL: K.ROBICHEAU	08/29/2019	
DRAWN BY: B.PARTHIBAN	08/20/2019	BURNDY															
CHECKER: L.TROMBLEY	04/29/2020																
DSN APRVL: L.TROMBLEY	04/29/2020																
MFG APRVL: T.WAWRZYNIAK	04/25/2020																
QA APRVL: J.BRODEUR	04/25/2020																
MKT APRVL: K.ROBICHEAU	08/29/2019																
<table border="1"> <tr> <td>PROD FAM: MECHANICAL GROUNDING</td> <td>DRAWING NO</td> <td>REV</td> </tr> <tr> <td>PROJECT #: --</td> <td>SIZE</td> <td></td> </tr> <tr> <td>DOCUMENT TYPE: SALES</td> <td>50104477</td> <td>B</td> </tr> <tr> <td>REL LEVEL: Released</td> <td>B</td> <td>SHEET 1 OF 1</td> </tr> </table>		PROD FAM: MECHANICAL GROUNDING	DRAWING NO	REV	PROJECT #: --	SIZE		DOCUMENT TYPE: SALES	50104477	B	REL LEVEL: Released	B	SHEET 1 OF 1				
PROD FAM: MECHANICAL GROUNDING	DRAWING NO	REV															
PROJECT #: --	SIZE																
DOCUMENT TYPE: SALES	50104477	B															
REL LEVEL: Released	B	SHEET 1 OF 1															