

REV	DATE	DESCRIPTION	ECO	BY	C'H'K.
A	04/13/2020	NEW DRAWING CREATION	53617	YR	SS

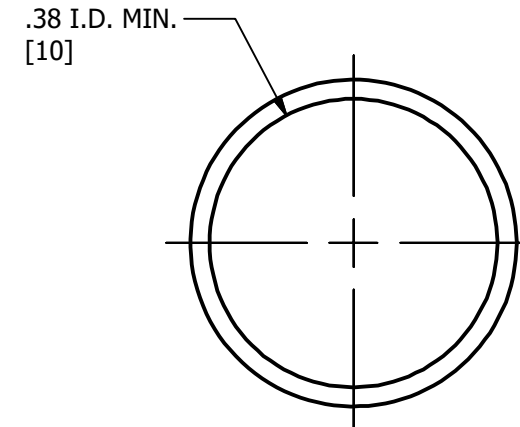

AS RECEIVED

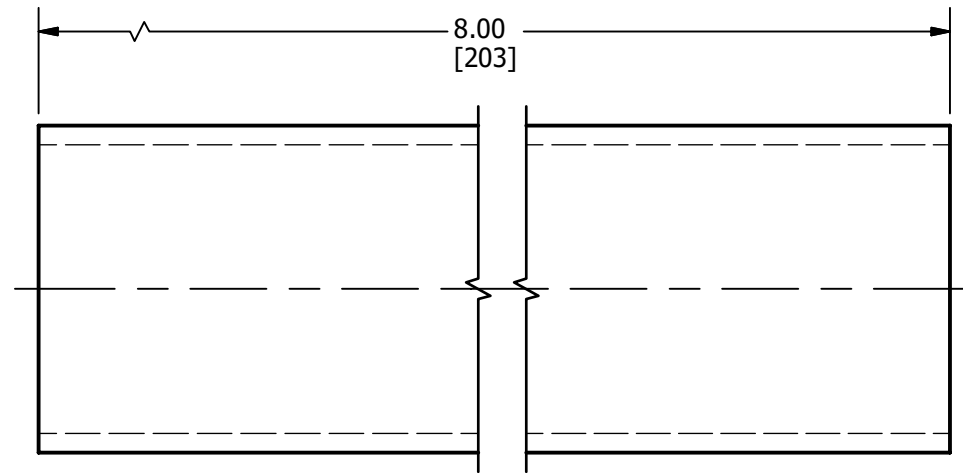
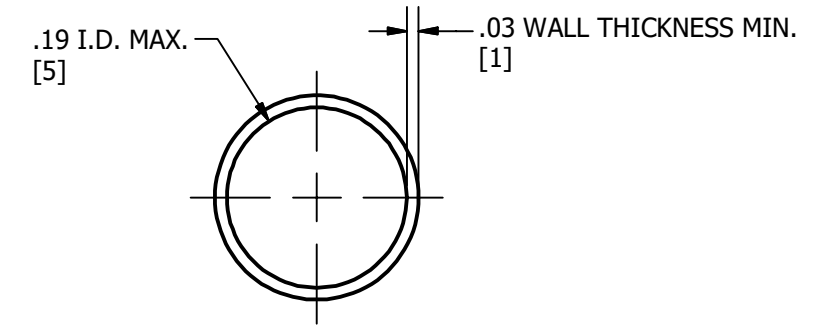

AFTER RECOVERY

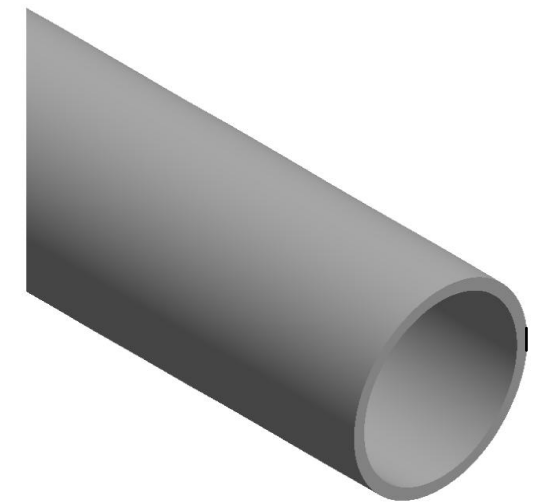

NOTES:

1. MATERIAL: FLEXIBLE POLYVINYL CHLORIDE.
2. DIMENSIONS IN BRACKETS [] ARE IN MILLIMETERS ROUNDED OFF TO THE NEAREST MILLIMETER, UNLESS OTHERWISE SPECIFIED AND ARE FOR REFERENCE ONLY.
3. SHRINK TEMPERATURE: 135°C (275°F) NOMINAL.
4. OPERATING TEMPERATURE RANGE FROM 20°C TO 105°C .
5. MUST HAVE OF 2:1 SHRINK RATIO.
6. HEAT SHRINKABLE PVC TUBING.
7. UL-224 105°C, 600V, VW-1 (FLAME RETARDENT).
8. SHRINK INSTRUCTIONS:
 A) THE ARTICLE TO BE COVERED MUST BE CLEAN AND DRY.
 B) INSERT THE ARTICLE TO BE COVERED INTO TUBING.
 C) APPLY HEAT TO THE TUBING WITH A BACK AND FORTH MOTION FROM END TO END.
 D) REMOVE HEAT AS SOON AS THE TUBING BEGINS TO ASSUME THE SHAPE OF THE ARTICLE.

TO ORDER BURNDY® PRODUCTS CALL		HEAT SHRINK TUBING	
UNITED STATES 1-800-346-4175 (LONDONDERRY, NH)		ITEM NO: 10101980	
CANADA: 1-800-361-6975 (QUEBEC) 1-800-387-6487 (ALL OTHER PROVINCES)		CAT. NO: HSC38FRL8	
FOR PRODUCT INFO: http://www.burndy.com		DRAWN BY: R.YOGARA 04/13/2020	
		CHECKER: S.SAURABH 04/13/2020	
		DSN APRVL: --	
		MFG APRVL: --	
		QA APRVL: --	
		MKT APRVL: --	
		PROD FAM: --	
		DRAWING NO	
		50105062	
		REV	
		A	
		PROJECT #: --	
		SIZE	
		B	
		DOCUMENT TYPE: SALES	
		REL LEVEL: Released	
		SHEET 1 OF 1	