

CATALOG NUMBER	CONDUCTOR		BOLT SIZE	BURNDY® INSTALLATION TOOLING (# CRIMPS)						
	AWG/KCMIL	MM <sup>2</sup> (CLASS 5)		DIE INDEX	COLOR CODE	MECHANICAL MD6, OUR840, MD7-34R	HYDRAULIC BCT500HS, Y500CTHS		Y35, Y39, Y750 Y46,  PAT750	DIELESS (# OF CRIMPS)
YAV29LTC14FXB	250 kcmil 4/0 Flex G,H,I,K,M, DLO (550/24)	--	1/4 [M6]	16	YELLOW	W29VT (2) X29RT (4)	W29VT (2) W29RT (2) X29RT (4)	U29RT (1)	Y / PAT644HSXT (1) MY29-11 (1) Y / PAT81KFT (1) Y / PAT4PC834 (1)	1-1/16"

REV	DATE	DESCRIPTION	ECO	BY	C'H'K.
A	06/26/2020	NEW DRAWING CREATION	53789	YR	SS

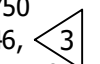
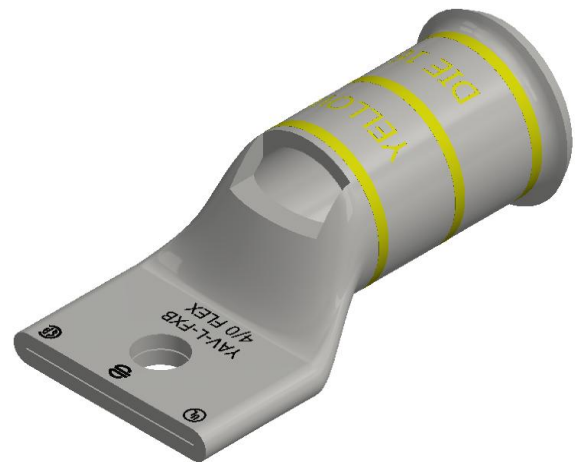
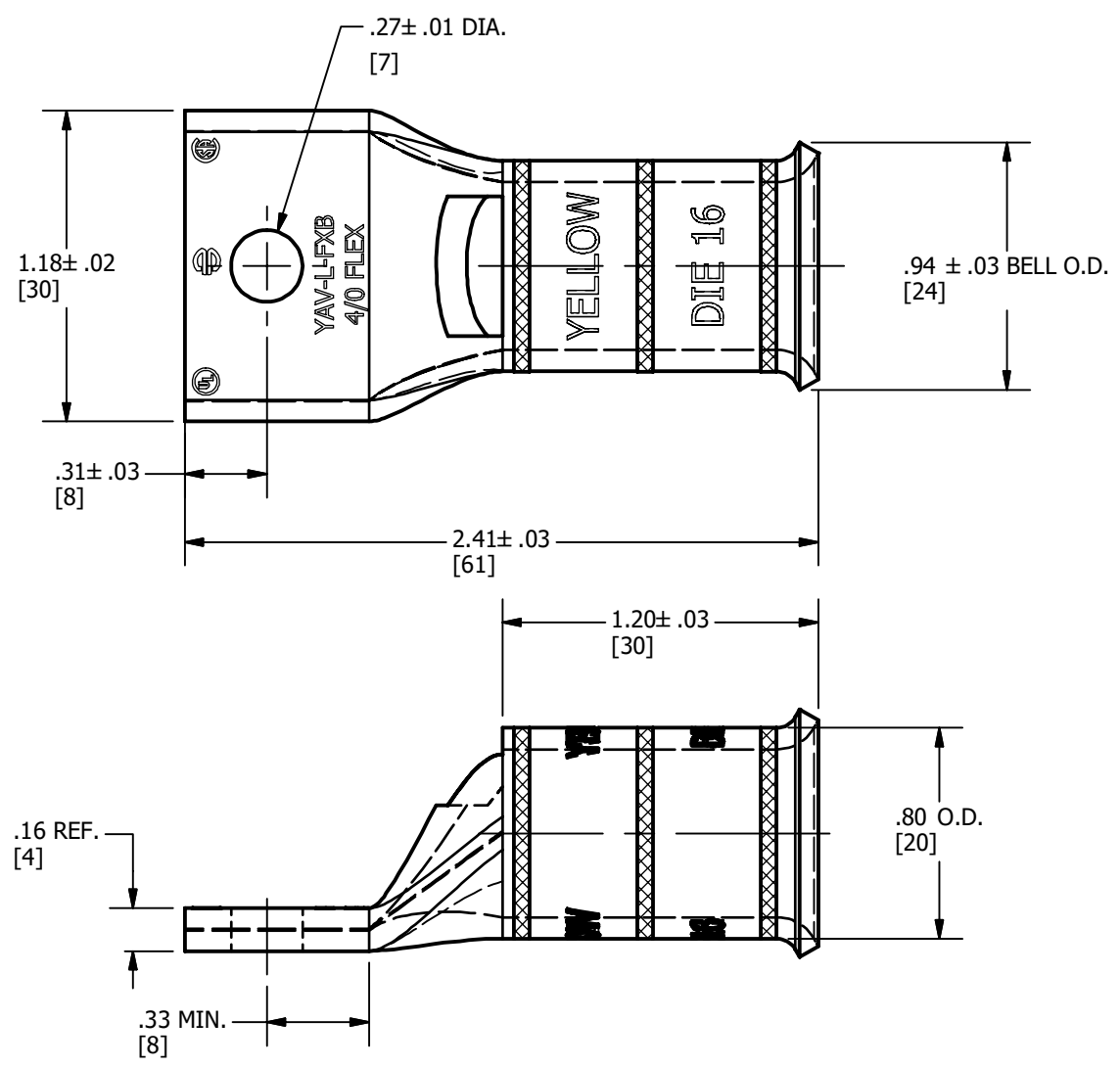

**NOTES:**

1. MATERIAL: COPPER TUBING.
2. FINISH: TIN PLATED.
3. CATALOG # PUADP-1 ADAPTOR IS REQUIRED TO USE "U" DIES IN Y46 SERIES TOOLS.
4. CONNECTORS ARE UL LISTED AND CSA CERTIFIED. UNDRILLED VERSIONS ARE NOT LISTED OR CERTIFIED.
5. DIMENSIONS IN BRACKETS [ ] ARE IN MILLIMETERS ROUNDED OFF TO THE NEAREST MILLIMETER, UNLESS OTHERWISE SPECIFIED AND ARE FOR REFERENCE ONLY.

TO ORDER BURNDY® PRODUCTS CALL		HYLUG™, BELLED 4/0 FLEX (550/24)	
UNITED STATES 1-800-346-4175 (LONDONDERRY, NH)		ITEM NO: 10037852	
CANADA: 1-800-361-6975 (QUEBEC) 1-800-387-6487 (ALL OTHER PROVINCES)		CAT. NO: YAV29LTC14FXB	
FOR PRODUCT INFO: <a href="http://www.burndy.com">http://www.burndy.com</a>		DRAWN BY: R.YOGARA 06/26/2020	
		CHECKER: M.SAURABH 06/26/2020	
		DSN APRVL: --	
		MFG APRVL: --	
		QA APRVL: --	
		MKT APRVL: --	
		PROD FAM: CM&R COMPRESSION	
		DRAWING NO	
		PROJECT #: --	
		SIZE	
		DOCUMENT TYPE: SALES	
		50105097	
		REL LEVEL: Released	
		B	
		SHEET 1 OF 1	
		A	