

CATALOG NUMBER	CONDUCTOR		Stud Hole Size	COLOR CODE	DIE INDEX	INSTALLATION TOOLING (# CRIMPS)				
	AWG/KCMIL	MM ² CLASS 5				MECHANICAL	HYDRAULIC		DIELESS (# OF CRIMPS)	WIRE STRIP LENGTH
						MD6, OUR840, MD7-34R	BCT500HS, Y500CHS	Y35, Y39, Y750, Y46, PAT750		
YA8CTC14FXB	#8 AWG #8 Flex G,H,I,K,M DLO (37/24) #6 Sol #8 Sol	10	1/4	RED	49	W8CVT (2)	W8CVT (2)	U8CRT (2)	MRC840 (2) MY29-11 (2) Y122CMR (2) Y1MRTC (2) Y / PAT81KFT (1)	1

REV	DATE	DESCRIPTION	ECO	BY	CH'K.
A	06/26/2020	NEW DRAWING CREATION	53788	SS	YR

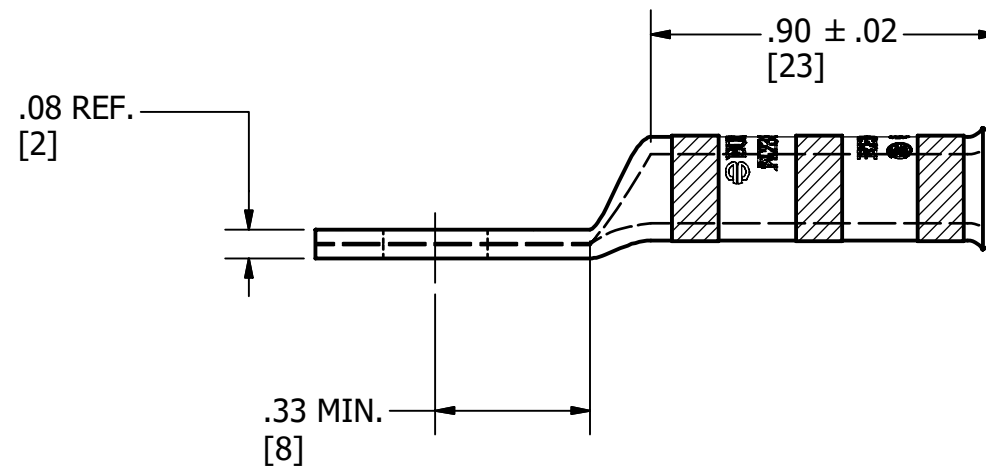
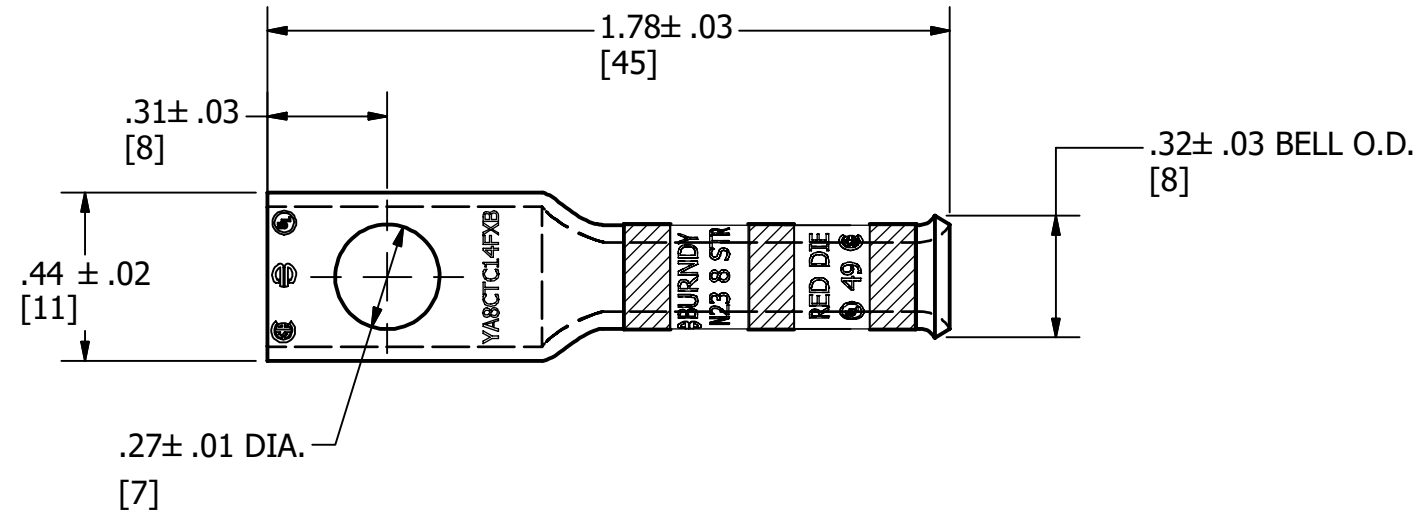

NOTES:

1. MATERIAL: COPPER TUBING.
2. FINISH: TIN PLATED.
3. CATALOG # PUADP-1 ADAPTOR IS REQUIRED TO USE "U" DIES IN Y46 SERIES TOOLS
4. DIMENSIONS IN BRACKETS [] ARE IN MILLIMETERS ROUNDED OFF TO THE NEAREST MILLIMETER, UNLESS OTHERWISE SPECIFIED AND ARE FOR REFERENCE ONLY.
5. CONNECTORS RE UL LISTED AND CSA CERTIFIED, UNDRILLED VERSIONS ARE NOT LISTED OR CERTIFIED.

TO ORDER BURNDY® PRODUCTS CALL
 UNITED STATES
 1-800-346-4175 (LONDONDERRY, NH)
 CANADA:
 1-800-361-6975 (QUEBEC)
 1-800-387-6487 (ALL OTHER PROVINCES)
 FOR PRODUCT INFO: <http://www.burndy.com>

HYLUG™, BELLED 3/0 FLEX (450/24)	
ITEM NO: 518671	
CAT. NO: YA8CTC14FXB	
DRAWN BY: M.SAURABH 6/29/2020	
CHECKER: R.YOGARAJ 6/29/2020	
DSN APRVL: R.ROMAN 9/10/2020	
MFG APRVL: --	
QA APRVL: J.BRODEUR 9/9/2020	
MKT APRVL: B.MICHAUD 9/9/2020	
PROD FAM: --	
PROJECT #: --	SIZE
DOCUMENT TYPE: SALES	50105115
REL LEVEL: Released	B
DRAWING NO	REV
50105115	A
SHEET 1 OF 1	

