

CATALOG NO.	CONDUCTOR		BOLT SIZE	INSTALLATION TOOLING (# CRIMPS)				DIELESS (# CRIMPS)	WIRE STRIP LENGTH	
				COLOR CODE	DIE INDEX	MECHANICAL	HYDRAULIC			
	FLEX	MM ² CLASS 5				MD6, OUR840, MD7-34R	BCT500HS, Y500CTHS			Y35, Y39, Y750, Y46, PAT750
YAZV26TC12FXB	2/0 AWG 2/0 Flex G, H, I, K, M, DLO (275/24)	70	1/2 [M12]	BLACK	13	W26VT (4) W26RT (4) X26RT (4)	W26VT (4) W26RT (4) X26RT (4)	U26RT (2)	MY29-11 (2) Y / PAT644 (1) Y / PAT81KFT (2)	1-9/16"

REV	DATE	DESCRIPTION	ECO	BY	CHK.
A	07/01/2020	NEW DRAWING CREATION	53788	SS	YR

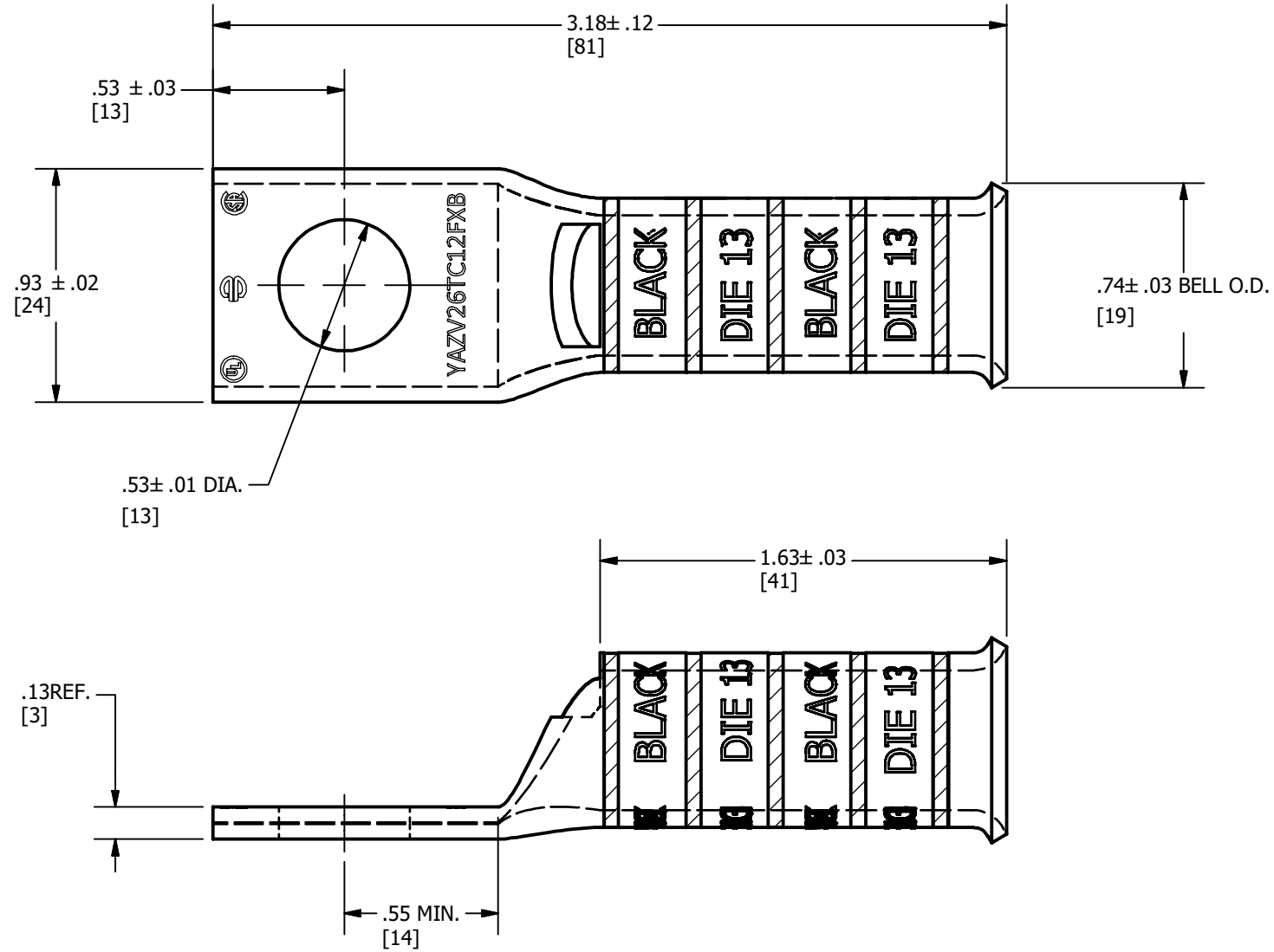

NOTES:

1. MATERIAL: COPPER TUBING.
2. FINISH: ELECTRO TIN PLATED.
3. CATALOG # PUADP-1 ADAPTOR IS REQUIRED TO USE "U" DIES IN Y46 SERIES TOOLS.
4. DIMENSIONS IN BRACKETS [] ARE IN MILLIMETERS ROUNDED OFF TO THE NEAREST MILLIMETER, UNLESS OTHERWISE NOTED, AND ARE FOR REFERENCE ONLY.
5. CONNECTOR ARE UL LISTED AND CSA CERTIFIED, UNDRILLED VERSIONS ARE NOT LISTED OR CERTIFIED.

TO ORDER BURNDY PRODUCTS CALL		HYLUG™	
UNITED STATES		ITEM NO: 10061489	
1-800-346-4175 (LONDONDERRY, NH)		CAT. NO: YAZV26TC12FXB	
CANADA:		DRAWN BY: M.SAURABH 7/1/2020	
1-800-361-6975 (QUEBEC)		CHECKER: R.YOGARAJ 7/1/2020	
1-800-387-6487 (ALL OTHER PROVINCES)		DSN APRVL: R.ROMAN 9/10/2020	
FOR PRODUCT INFO: http://www.burndy.com		MFG APRVL: --	
		QA APRVL: J.BRODEUR 9/9/2020	
		MKT APRVL: B.MICHAUD 9/9/2020	
		PROD FAM: --	
		DRAWING NO	
		50105118	
		REV	
		A	
		SHEET 1 OF 1	