

BURNDY® INSTALLATION TOOLING (# CRIMPS)								
DIE INDEX	COLOR CODE	MECHANICAL		HYDRAULIC			DIELESS	WIRE STRIP LENGTH
		MD6 MD7	BCT500 Y500CT PAT600	Y750, Y35 Y39, PAT750	Y46 PAT46	Y45		
19 OR 470	BLUE	W32VT (2)	W32RT (2) W32VT (2)	U32RT (2)	U32RT (2)	U32RT (2)	HYDRAULIC: Y644M (1) PAT644 (1) Y61KFT (2) Y4PC834 (2) PAT444 (1) Y444 (1)	1 - 5/16"

Catalog Number	Fig No	B ±.06	C ±.04	E ±.02	K ±.02	L ±.12	OD ±.01	N ±.03	(T)	Ymin	Z min
YAG34L2NTCFXTZ	2	1.27	1.55	1.75	0.56	5.11	1.06	0.63	0.23	2.40	-
YAG34LTC516N66FXTZ	1	1.27	1.55	-	0.33	3.09	1.06	0.66	0.23	-	0.36
YAG34L2TC38FXTZ	2	1.27	1.55	1.00	0.41	3.92	1.06	0.41	0.23	1.43	-
YAG34LTC12FXTZ	1	1.27	1.55	-	0.53	3.16	1.06	0.53	0.23	-	0.55
YAG34LTC516FXTZ	1	1.27	1.55	-	0.33	2.78	1.06	0.34	0.23	-	0.36
YAG34LTC38FXTZ	1	1.27	1.55	-	0.41	2.91	1.06	0.41	0.23	-	0.42

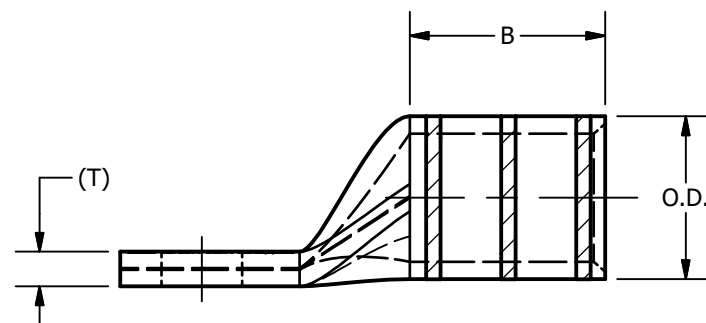

**FIG. 1**

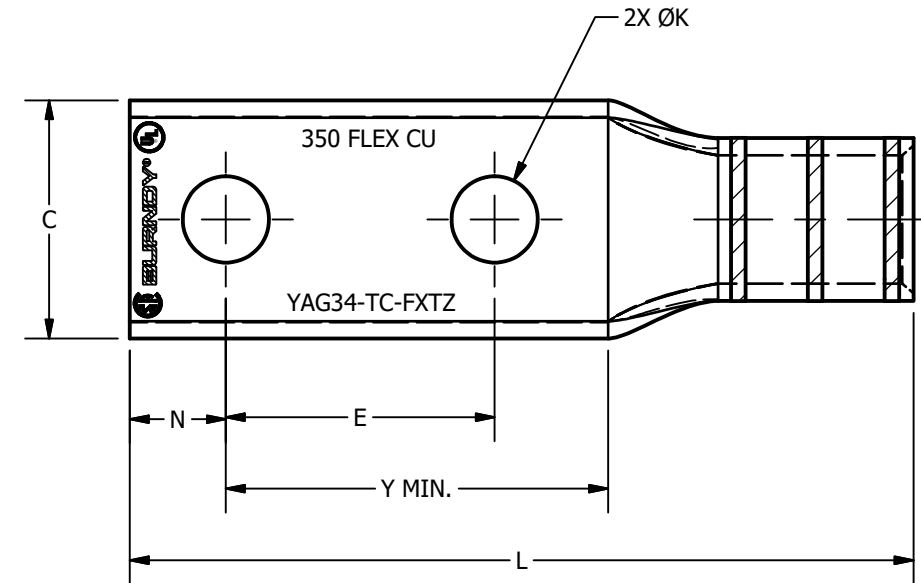
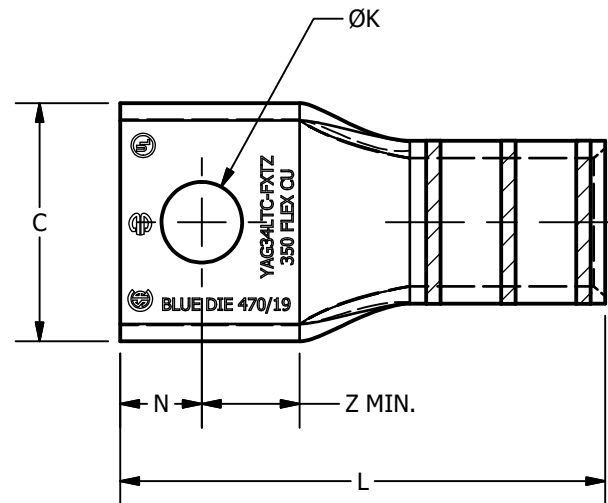
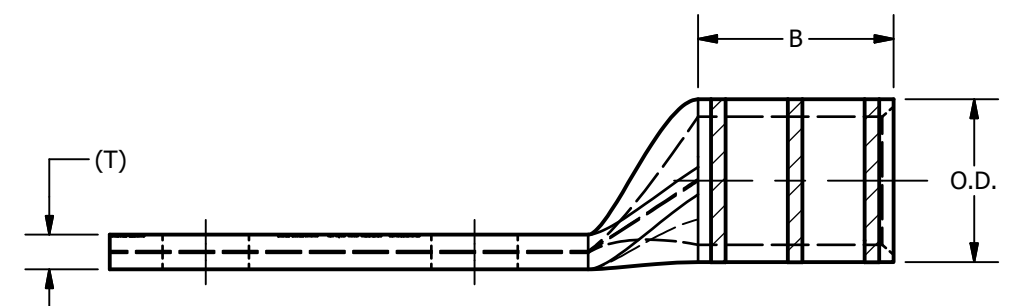

**FIG. 2**

**NOTES:**

1. MATERIAL: COPPER TUBING TIN - ZINC PLATED
2. UL LISTED AND CSA CERTIFIED CONNECTOR.

REV	DATE	DESCRIPTION	ECO	BY	C'H'K.
A	10/22/2019	NEW DRAWING	52375	JL	RR

TO ORDER BURNDY® PRODUCTS CALL

UNITED STATES  
1-800-346-4175 (LONDONDERRY, NH)

CANADA:  
1-800-361-6975 (QUEBEC)  
1-800-387-6487 (ALL OTHER PROVINCES)

FOR PRODUCT INFO: <http://www.burndy.com>

HYLUG™	
ITEM NO: SEE TABLE	
CAT. NO: SEE TABLE	
DRAWN BY: JL BERGERON	10/22/2019
CHECKER: R.ROMAN	10/22/2019
DSN APRVL: R.ROMAN	11/26/2019
MFG APRVL: -	
QA APRVL: B.ELLIOTT	11/26/2019
MKT APRVL: B.MICHAUD	11/25/2019
PROD FAM: TOOLS, MECHANICAL	DRAWING NO
PROJECT #: NPD02763	SIZE
DOCUMENT TYPE: SALES	50106556
REL LEVEL: Released	B
	SHEET 1 OF 1
	REV
	A

