

REV	DATE	DESCRIPTION	ECO	BY	CHK.
A	10/11/2021	BROUGHT TO RELEASE	210922012600	JL	KC

STRANDED COPPER CONDUCTOR ACCOMMODATED	BOLT SIZE	METRIC BOLT SIZE	COLOR CODE	DIE INFORMATION		HYDRAULIC			DIELESS (# CRIMPS)	WIRE STRIP LENGTH
				DIE INDEX	TYPE	Y46 PAT46	Y45	Y60BHU		
650 KCMIL CLASS G 646 KCMIL DLO	1/2	M12	BLACK	24	BLACK DIE SET	P39RT (2)	S39RT (2)	L39RT (1)	HYDRAULIC: Y644 (1) PAT644 (1) Y81KFT (4) PAT81KFT (4) Y4PC834 (4) PAT4PC834 (4)	3"

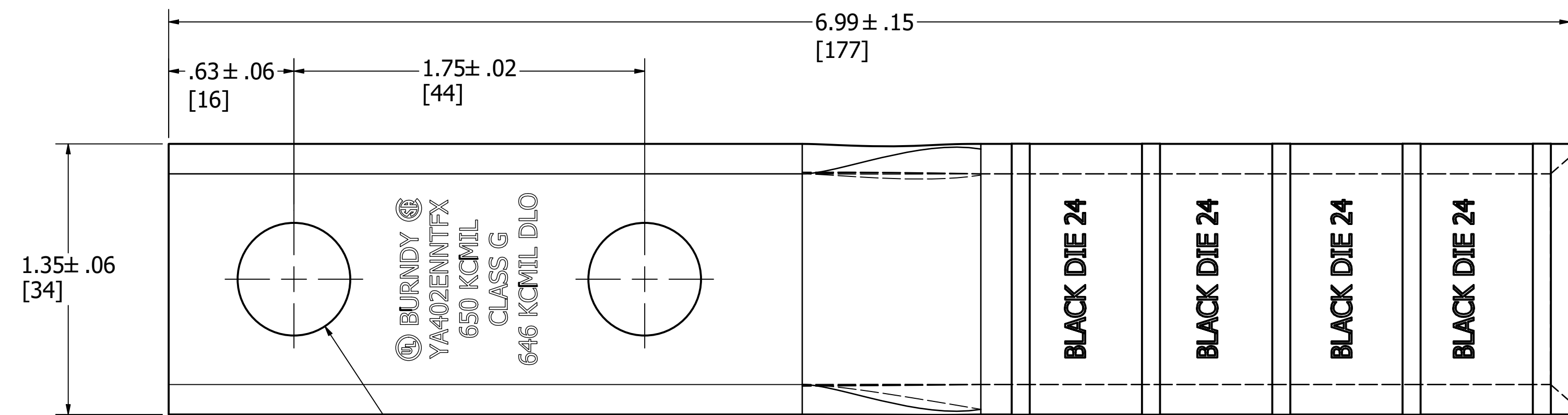

BARREL MARKING

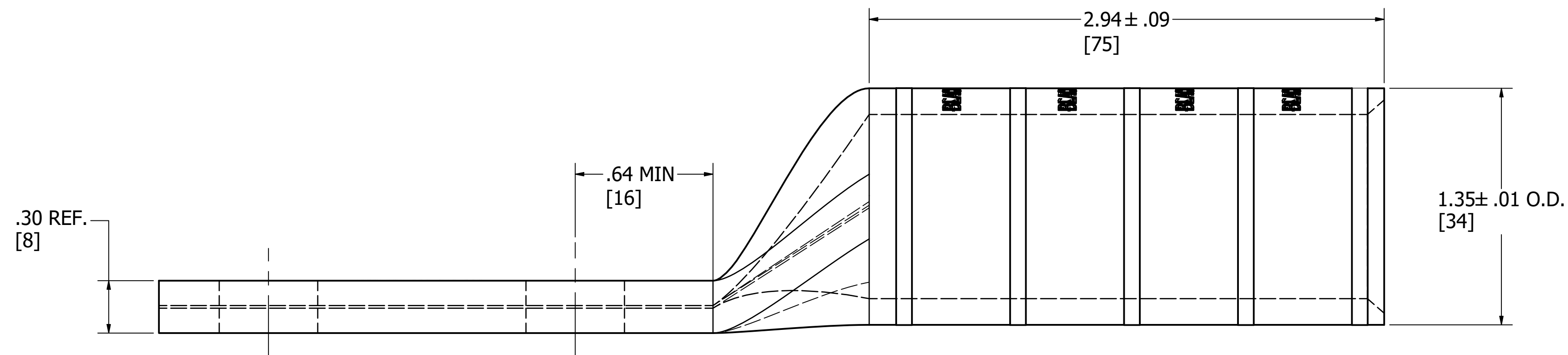

NOTES:

1. MATERIAL: COPPER TUBING
2. FINISH: TIN PLATED.
3. DIMENSIONS IN BRACKETS [ ] ARE IN MILLIMETERS ROUNDED OFF TO THE NEAREST MILLIMETER, UNLESS OTHERWISE NOTED, AND ARE FOR REFERENCE ONLY.
4. UL LISTED AND CSA CERTIFIED WIRE CONNECTOR.
5. "P", & "L" DIE SETS ARE COLOR CODED. "S" DIE SET IS NOT COLOR CODED. NEST AND INDENTOR TYPE ARE NOT COLOR CODED.

TO ORDER BURNDY® PRODUCTS CALL		HYLUG™	
UNITED STATES 1-800-346-4175 (LONDONDERRY, NH)		ITEM NO: 50110185	
CANADA: 1-800-361-6975 (QUEBEC) 1-800-387-6487 (ALL OTHER PROVINCES)		CAT. NO: YA402ENNTFX	
FOR PRODUCT INFO: <a href="http://www.burndy.com">http://www.burndy.com</a>		DRAWN BY: R.YOGARAJ 5/5/2020	
		CHECKER: S.SAURABH 5/5/2020	
		DSN APRVL: R.ROMAN 10/19/2021	
		MFG APRVL: J.MICHAUD 10/14/2021	
		QA APRVL: J.BRODEUR 10/14/2021	
		MKT APRVL: --	
		PROD FAM: CM&R COMPRESSION	
		DRAWING NO	
		50111162	
		SHEET 1 OF 1	
		REV	
		A	