

REV	DATE	DESCRIPTION	ECO	BY	C'H.K.
A	10/22/2020	NEW SALES DRAWING CREATED	54292	YR	PB

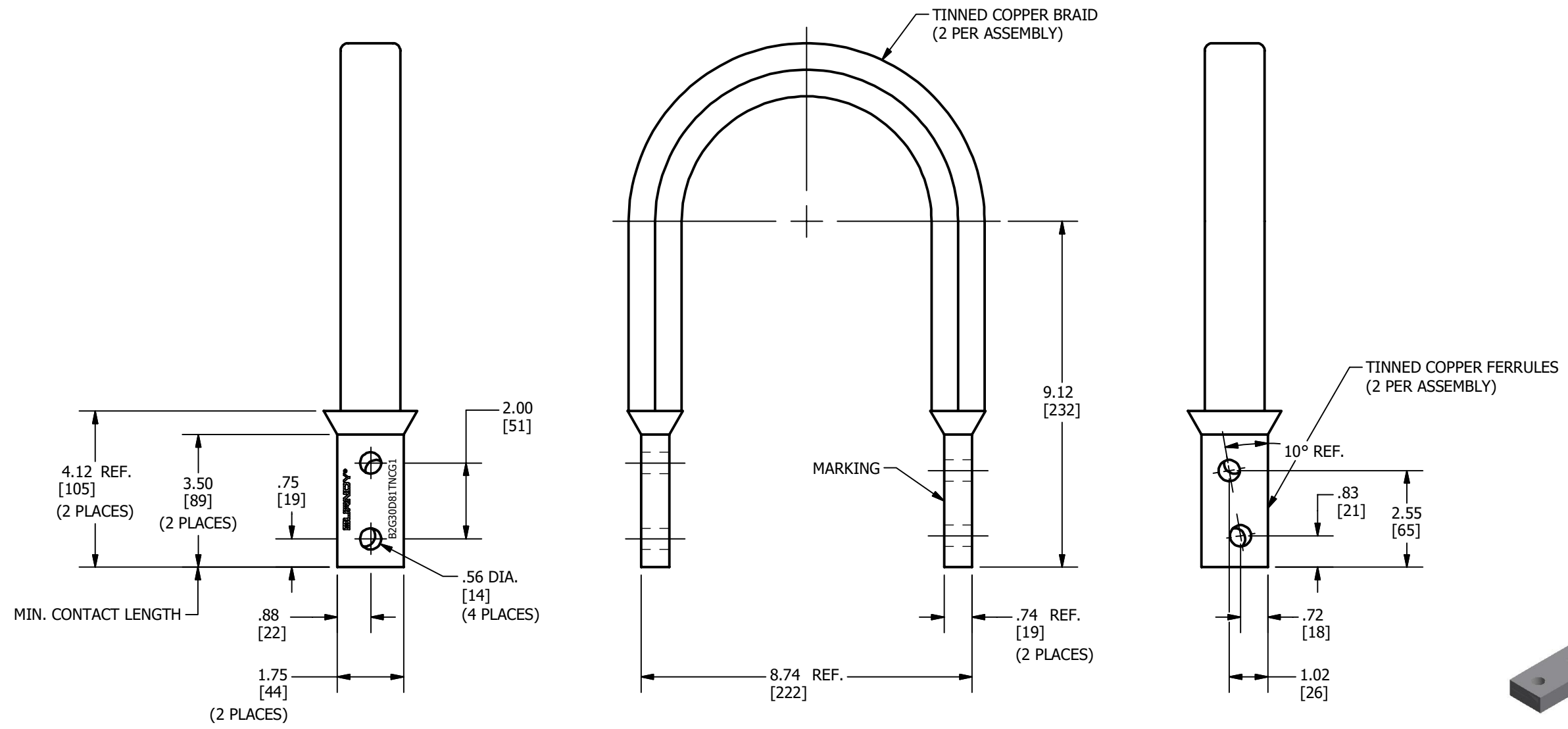

**NOTES:**

1. MATERIAL: FERRULES - TINNED COPPER  
BRAID - TINNED COPPER  
INSULATION - GREY PLASTISOL (U.V. STABILIZED)
2. RECOMMENDED BOLT TORQUE VALUE FOR 1/2"-13 BOLT: 480 IN-LBS
3. DESIGN AMPACITY: 700 AMPS @ 30C TEMPERATURE RISE OVER 40°C AMBIENT  
(BRAID AMPACITY IS GREATER THAN OR EQUAL TO 535 MCM CABLE)
4. THE MAXIMUM OPERATING TEMPERATURE FOR THE PLASTISOL IS 10°C.
5. DIMENSIONS IN BRACKETS [ ] ARE IN MILLIMETERS ROUNDED OFF TO THE NEAREST MILLIMETER, UNLESS OTHERWISE SPECIFIED AND ARE FOR REFERENCE ONLY.

TO ORDER BURNDY® PRODUCTS CALL  UNITED STATES 1-800-346-4175 (LONDONDERRY, NH)  CANADA: 1-800-361-6975 (QUEBEC) 1-800-387-6487 (ALL OTHER PROVINCES)  FOR PRODUCT INFO: <a href="http://www.burndy.com">http://www.burndy.com</a>	RETURN CURRENT BRAID		
	ITEM NO: 10033499		
	CAT. NO: B2G30D81TNCG1		
	DRAWN BY: R.YOGARA	10/22/2020	
	CHECKER: S.CARBONNEAU	02/16/2021	
DSN APRVL: S.CARBONNEAU	02/16/2021		
MFG APRVL: --			
QA APRVL: G.REDFIELD	11/12/2020		
MKT APRVL: K.ROBICHEAU	02/23/2021		
PROD FAM: MECHANICAL GROUNDING	DRAWING NO	REV	
PROJECT #: --	SIZE	50115834	
DOCUMENT TYPE: SALES	B	A	
REL LEVEL: Released		SHEET 1 OF 1	