

CAT NO.	MATERIAL
WCH2-90-15	300 Series Stainless Steel
WCH2-90-15GS	Galvanized Spring Steel

REV	DATE	DESCRIPTION	EC	BY	C'H'K.
A	10-13-2022	DRAWING UPDATE	221013024814	TM	EM

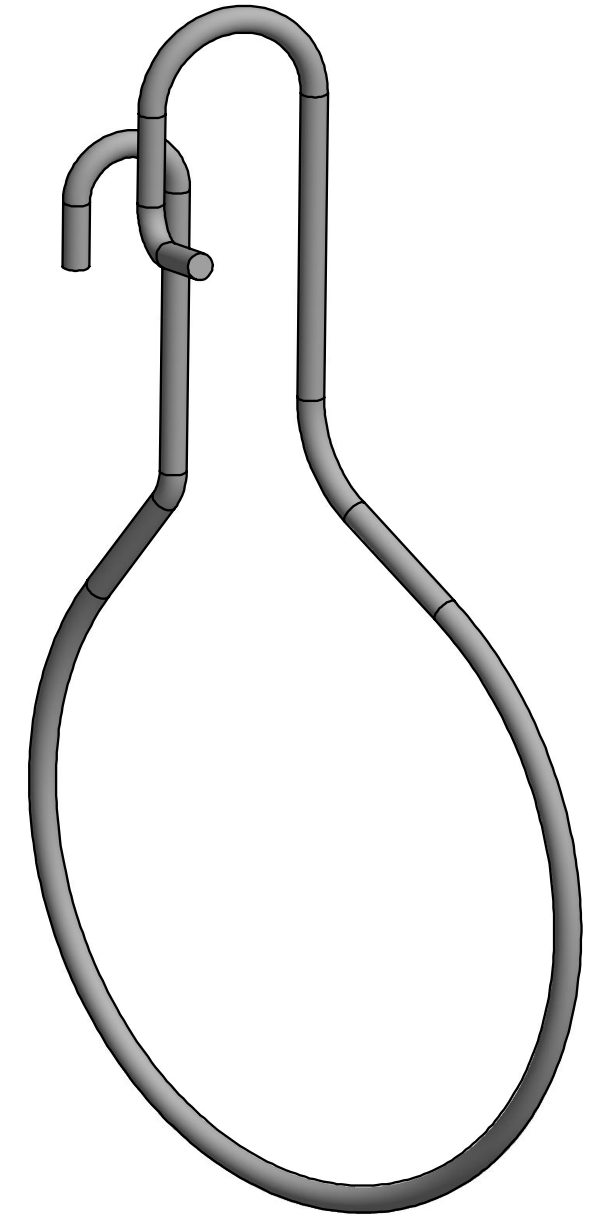
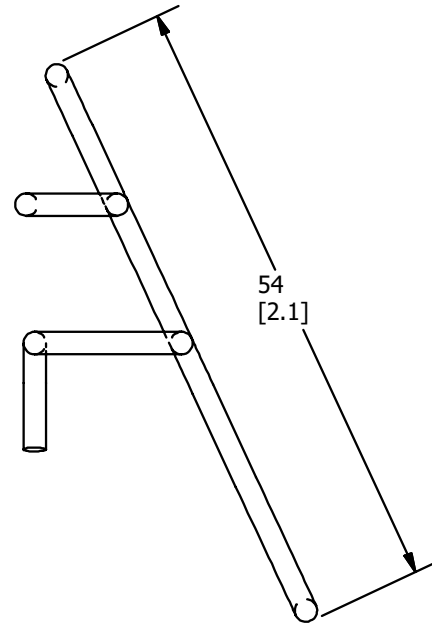
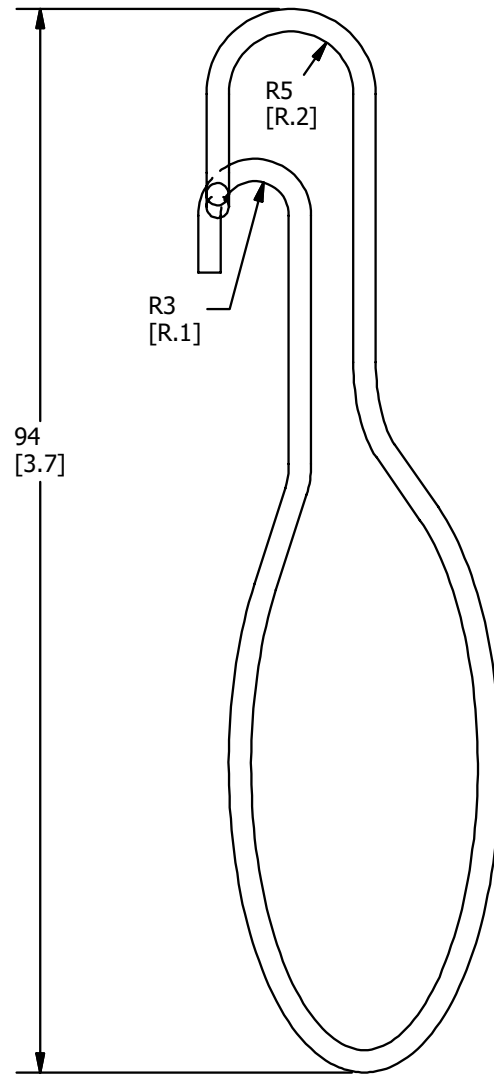
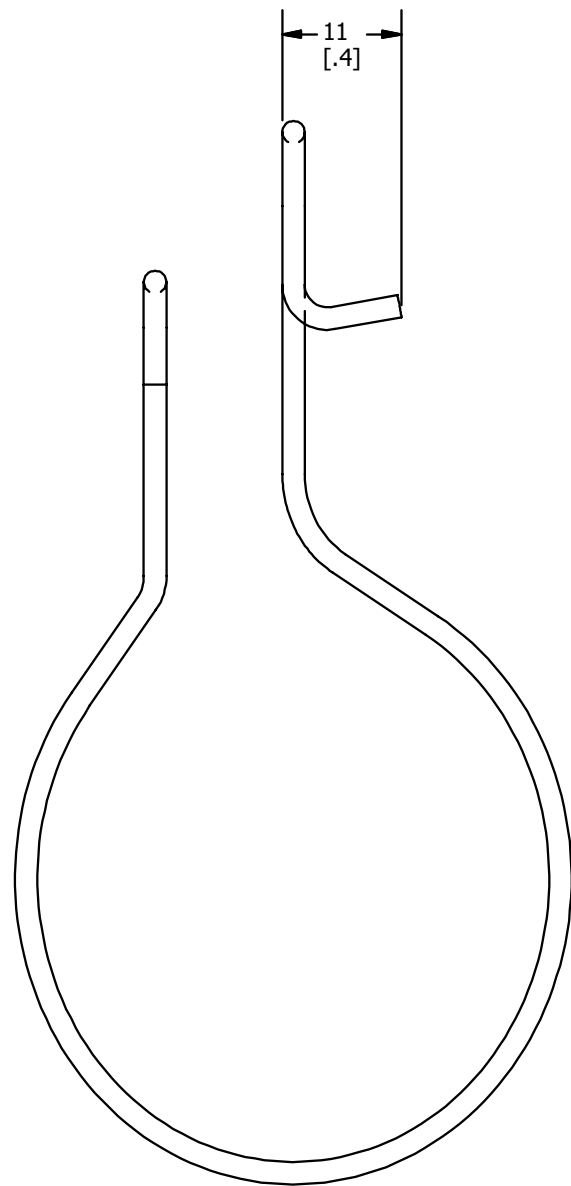

NOTES:

1. DIMENSIONS IN BRACKETS [] ARE IN INCHES ROUNDED OFF TO THE NEAREST TENTH, UNLESS OTHERWISE SPECIFIED AND ARE FOR REFERENCE ONLY.

TO ORDER BURNDY® PRODUCTS CALL

UNITED STATES
1-800-346-4175 (LONDONDERRY, NH)

CANADA:
1-800-387-6487

FOR PRODUCT INFO: <http://www.burndy.com>

CABLE HANGER

ITEM NO: --
CAT. NO: WCH2-90-15-- (SEE TABLE)

DRAWN BY: M.THAMARAI	04-21-2022
CHECKER: E.MARTIN	11-15-2022
DSN APRVL: E.MARTIN	11-15-2022
PUR APRVL: J.VERRANAULT	11-15-2022
QA APRVL: J.BRODEUR	11-15-2022
MKT APRVL: S.PARSONS	11-15-2022
PROD FAM: WILEY	



PROJECT #:	SIZE	DRAWING NO	REV
SALES	B	50127834	A
REL LEVEL: Released		SHEET 1 OF 1	