

| REV | DATE       | DESCRIPTION    | EC           | BY | C'H.K. |
|-----|------------|----------------|--------------|----|--------|
| A   | 07-12-2023 | DRAWING UPDATE | 230712031818 | TM | EM     |

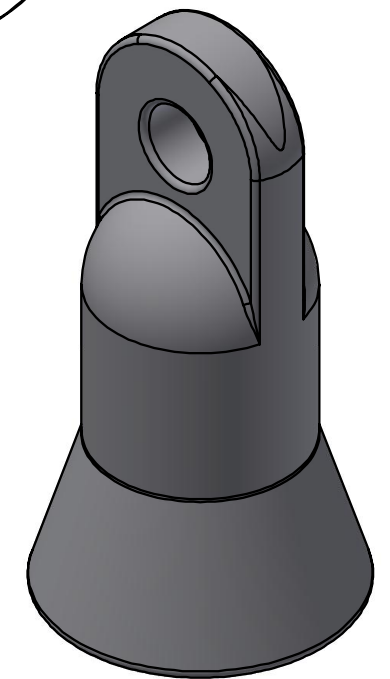
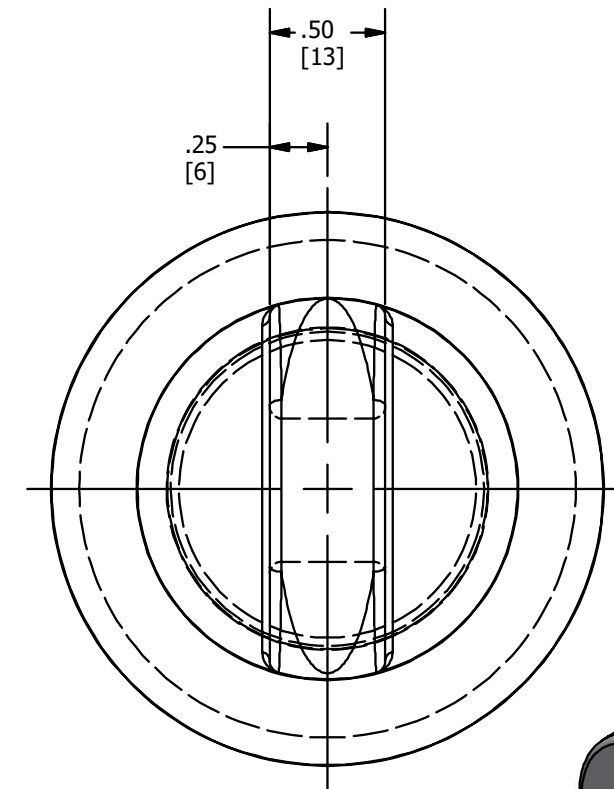
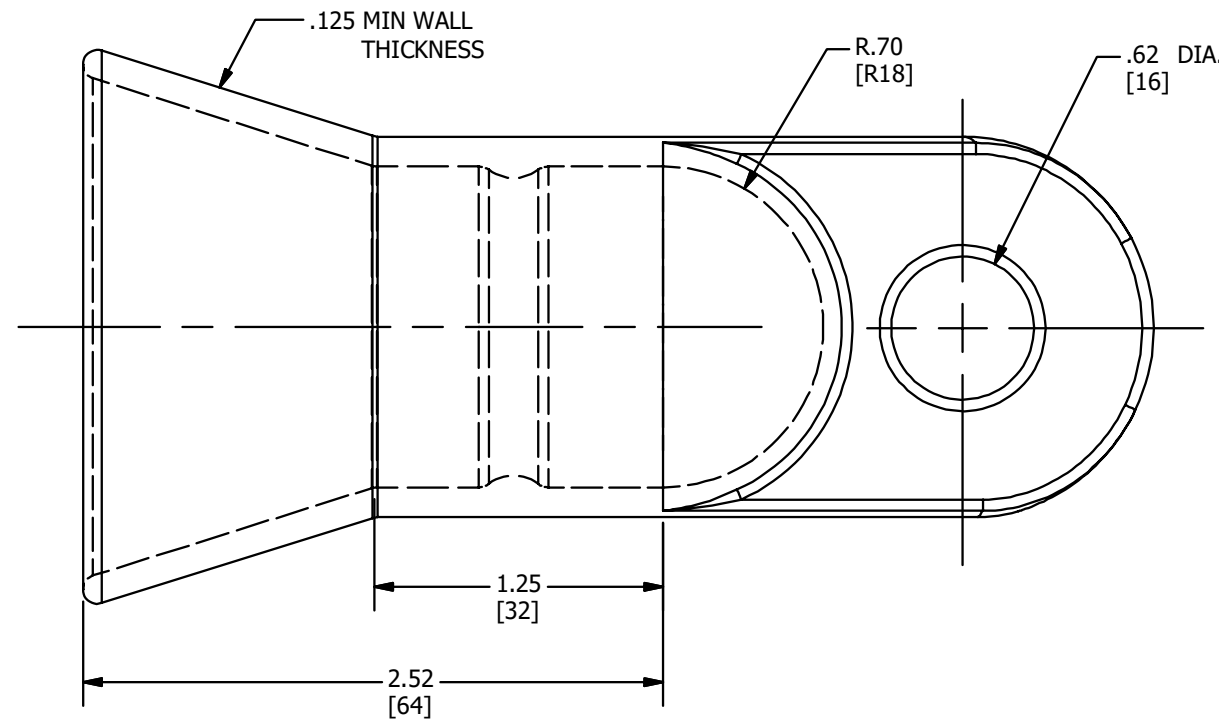
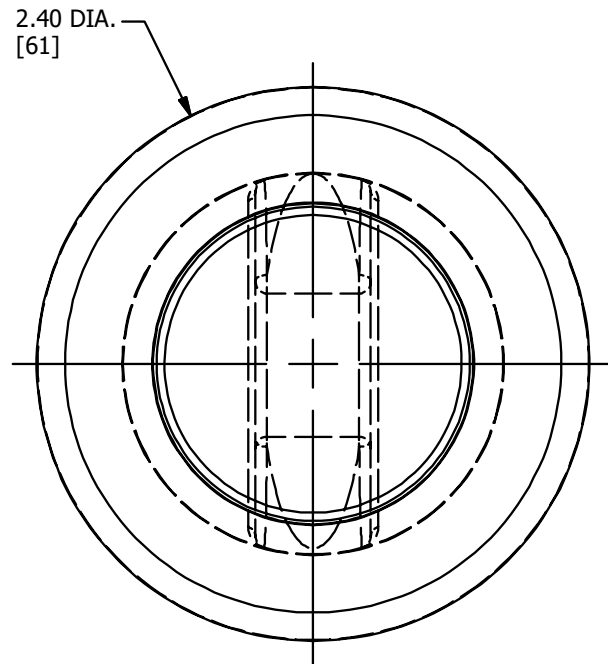

**NOTES:**

1. MATERIAL: ORANGE, THERMOPLASTIC ELASTOMER.
2. DIMENSIONS IN BRACKETS [ ] ARE IN MILLIMETERS ROUNDED OFF TO THE NEAREST MILLIMETER, UNLESS OTHERWISE SPECIFIED AND ARE FOR REFERENCE ONLY.

TO ORDER BURNDY® PRODUCTS CALL

UNITED STATES  
1-800-346-4175 (LONDONDERRY, NH)

CANADA:  
1-800-387-6487

FOR PRODUCT INFO: <http://www.burndy.com>

**BALL STUD COVER**

ITEM NO: 50131833

CAT. NO: GSC882NH35BCOVER

|                       |            |
|-----------------------|------------|
| DRAWN BY: M.THAMARAI  | 01-13-2023 |
| CHECKER: E.MARTIN     | 01-19-2023 |
| DSN APRVL: E.MARTIN   | 01-19-2023 |
| MFG APRVL: G.REDFIELD | 01-19-2023 |
| QA APRVL: G.REDFIELD  | 01-19-2023 |
| MKT APRVL: S.PARSONS  | 07-27-2023 |



|                      |            |              |
|----------------------|------------|--------------|
| PROD FAM: GROUNDING  | DRAWING NO | REV          |
| PROJECT #: --        | 50131835   | A            |
| DOCUMENT TYPE: SALES | SIZE: B    | SHEET 1 OF 1 |
| REL LEVEL: Released  |            |              |