

- NOTES:
- 1 CREEPAGE DISTANCE: 33.5" / 851mm
 - 2 ARC DISTANCE: 13.8" / 350mm
 - 3 NOMINAL VOLTAGE: 25kV
 - 4 NOMINAL CURRENT: 2700A
 - 5 VOLTAGE WITHSTAND, 60 sec.: 60kV
 - 6 BIL : 150kV
 - 7 ROUTINE TEST ACCORDING TO: IEEE C57.19.01
 - 8 MAX. TORQUE APPLIED ON FLANGE BOLTS: 40 lbf · ft / 54.2 N · m
 - 9 WEIGHT: 73 lb / 33.1 Kg
- △10 SILVER PLATED, AS PER ASTM B700, TYPE 1, GRADE D, CLASS N, NO NICKEL LAYER, FROM 13 TO 20 μm THICKNESS
- 11 BUSHING NOT SUITABLE FOR ENCLOSED APPLICATION

REVISIONS					
ZONE	REV.	DESCRIPTION	DRAWN BY	DATE	APPR.
B5	A	INCREASE THE CLEARANCE AROUND THE FLANGE MOUNTING HOLES	J.N.PILOTTE	2017-01-12	Y.V.
A6	B	CHANGE HOLES DIAMETER WAS Ø.88" BECOMES Ø1.00"	J.N.PILOTTE	2017-02-17	Y.V.

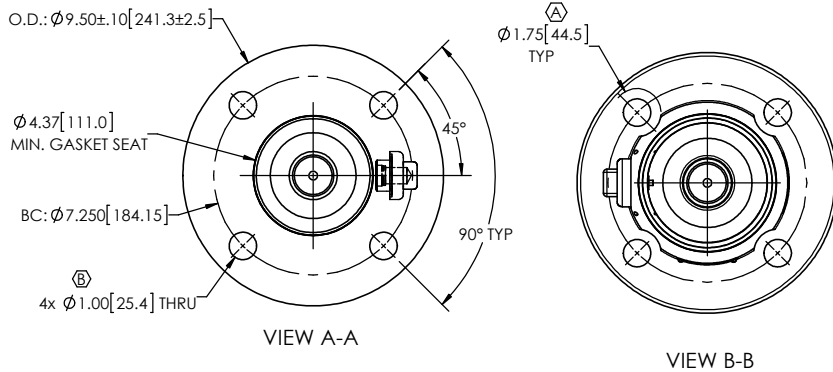
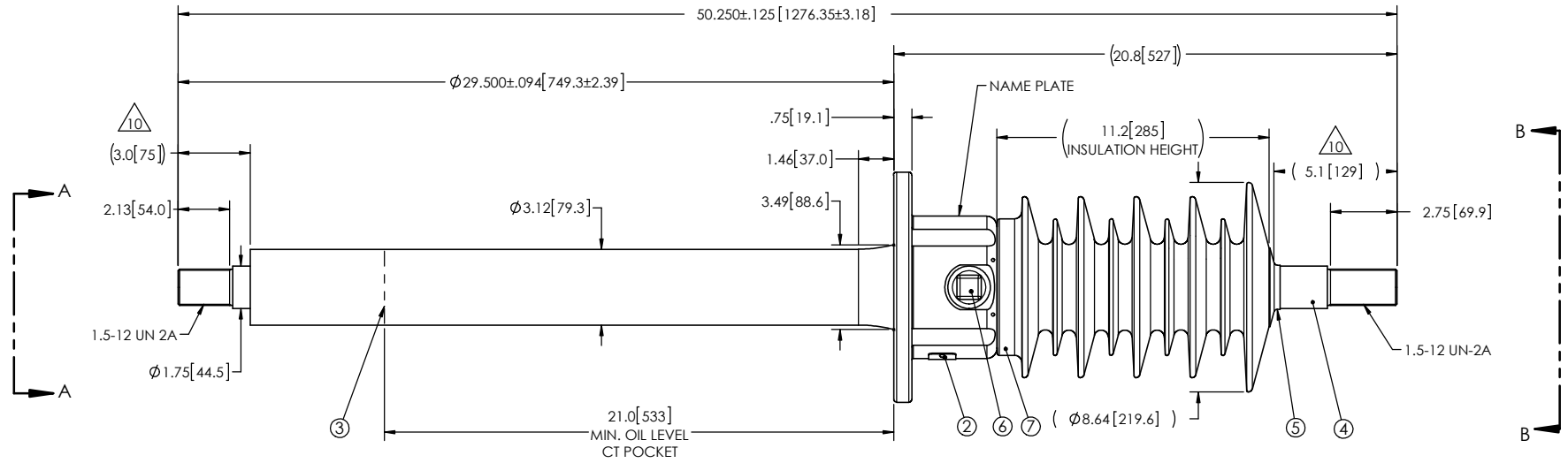

ITEM NO.	QTY	DRAWING NO.	PART NO.	DESCRIPTION	NOTE / MAT'L
6	1	S-1001-2022		CAPACITANCE TAP ASSEMBLY	ALUMINUM
5	1	S-1600-0587-0		CAP	COPPER
4	1	S-9135-8717		ROD ASSEMBLY	COPPER
3	1	S-6303-7647		SHIELD ASSEMBLY	COPPER
2	1	S-1770-9197		FLANGE	ALUMINUM
7	1	S-1770-9196	-001	CASTING, CYCLOALIPHATIC RESIN	EC-APG-15NA

GENERAL TOLERANCES (UNLESS OTHERWISE SPECIFIED)

X.	±0.125
.X	±0.094
.XX	±0.063
.XXX	±0.031
ANGLES	±0.25°
RADIUS	±0.031

REMOVE BURRS AND BREAK SHARP EDGES

DIMENSIONS ARE IN INCHES (UNLESS OTHERWISE SPECIFIED)

DRAWN BY: J.N.PILOTTE	DATE: 2016/09/22
CHECK BY:	
PROJECTING:	
PROJECT MANAGER:	

Electro Composites
solid HV bushings solution

TITLE: SDC® BUSHING 25kV, 2700A
MODEL: 150-027-T-537-09

FORMAT A	CAGE CODE	DRAWING NO. S-1770-9196	REVISION B
SCALE 1:7	GENERATED BY: SolidWorks 2013	SHEET 1 of 1	

This drawing is the proprietary property of Electro Composites (2008) ULC, not part of the public domain, and is issued with the express understanding and agreement that it is not to be reproduced or copied in whole or in part or issued for furnishing information to others, or used directly or indirectly, in any way detrimental to the interest of Electro Composites (2008) ULC and is to be returned upon request by Electro Composites (2008) ULC. All Rights Reserved.