

NOTES:

- 1 CREEPAGE DISTANCE AIR SIDE: 19.5" / 495mm
- 2 CREEPAGE DISTANCE NITROGEN SIDE: 17.6" / 448mm
- 3 NOMINAL VOLTAGE: 15kV
- 4 NOMINAL CURRENT: 2000A
- 5 WITHSTAND VOLTAGE AT 60 sec.: 50kV
- 6 BIL: 110kV
- 7 ROUTINE TEST ACCORDING TO: IEEE C57.19.01
- 8 MAX. TORQUE APPLIED ON FLANGE BOLTS: 40 lb.FT / 54.2 N.m
- 9 WEIGHT: 38 lbs / 17.3 Kg

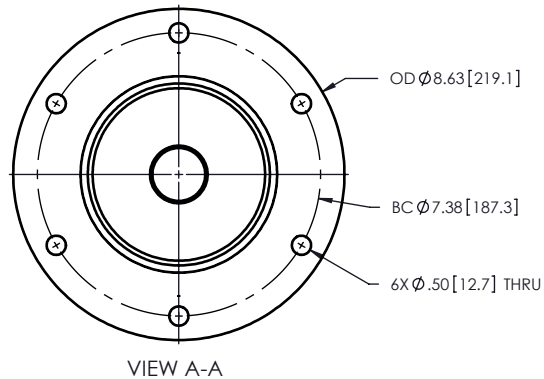
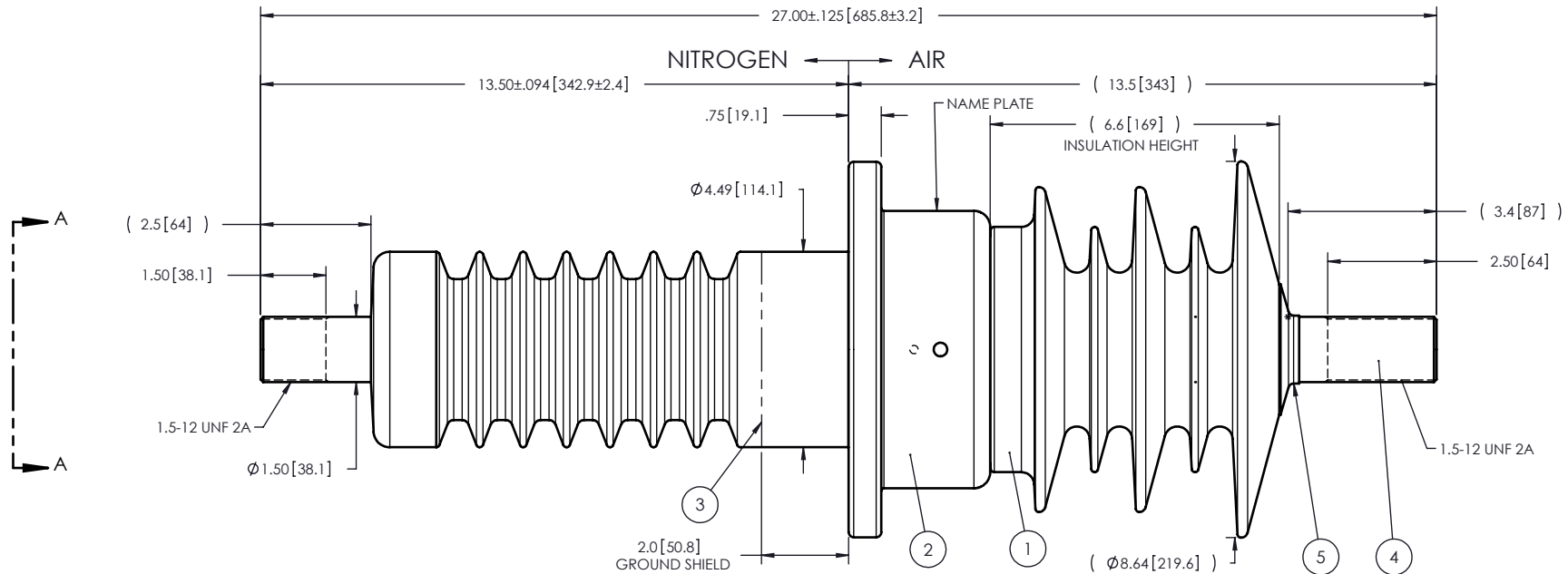

ITEM NO.	QTY	DRAWING NO.	PART NO.	DESCRIPTION	NOTE / MATL
5	1	S-1016-0008		CAP	COPPER
4	1	S-6517-6103		ROD ASSEMBLY	COPPER
3	1	S-5074-4805		SHIELD ASSEMBLY	COPPER
2	1	S-6517-6101		FLANGE	ALUMINUM
1	1	S-6517-6100	-001	CASTING, CYCLOALIPHATIC RESIN	EC-APG-02

PARTS LIST

GENERAL TOLERANCES (UNLESS OTHERWISE SPECIFIED) X. ±0.125 .X ±0.094 .XX ±0.063 .XXX ±0.010 ANGLES ±0.1° RADIUS ±0.031		REPLACE: DRAWN BY: J.N.PILOTTE DATE: 2010/09/14 CHECK BY: PROJECT ENG.: PROJECT MANAGER:		ElectroComposites™ solid HV bushings solution TITLE: BUSHING 15kV, 2000A MODEL: 110-020-W-575-00	
REMOVE BURRS AND BREAK SHARP EDGES DIMENSIONS ARE IN INCHES (UNLESS OTHERWISE SPECIFIED)		SCALE: 1:4		GENERATED BY: SolidWorks 2009 SHEET: 1 of 1	

This drawing is the proprietary property of Electro Composites (2008) ULC, not part of the public domain, and is issued with the express understanding and agreement that it is not to be reproduced or copied in whole or in part or issued for furnishing information to others, or used directly or indirectly, in any way detrimental to the interest of Electro Composites (2008) ULC and is to be returned upon request by Electro Composites (2008) ULC. All Rights Reserved.