

- NOTES:
- 1 CREEPAGE DISTANCE: 63.6" / 1615mm
  - 2 ARC DISTANCE: 27.2" / 690mm
  - 3 NOMINAL VOLTAGE: 69kV
  - 4 NOMINAL CURRENT: 400A
  - 5 VOLTAGE WITHSTAND, 60 sec.: 160kV
  - 6 BIL : 350kV
  - 7 ROUTINE TEST ACCORDING TO: IEEE C57.19.01
  - 8 MAX. TORQUE APPLIED ON FLANGE BOLTS: 70 lbf·ft / 94.9 N·m  $\triangle A$
  - 9 WEIGHT: 71 lb / 32.2 kg
- $\triangle A$  SILVER PLATED, AS PER ASTM B700, TYPE 1, GRADE D, CLASS N, NO NICKEL LAYER, FROM 13 TO 20 MICROMETERS THICKNESS

REVISIONS					
ZONE	REV.	DESCRIPTION	DRAWN BY	DATE	APPR.
A2 B4		ADD THE "SDC" DESIGNATION TO THE BUSHING NAME. THREAD TERMINAL S-6630-6191-1 STANDARDIZE TO S-6245-6112-1 TUBE AND CAP MATERIAL CHANGE FROM BRASS TO ALUMINUM SHIELD ASSEMBLY CHANGED FROM S-5158-4682 TO S-6630-10097	M. FORGET	2020-03-05	J.V.
C5 E6 F5	A	ADD THE MINIMUM GASKET SEAT DIMENSION. INCREASE THE TOLERANCES ON THE FLANGE OUTSIDE DIAMETER. MAX. TORQUE APPLIED ON FLANGE BOLT CHANGE FROM 40 lbf·ft TO 70 lbf·ft			

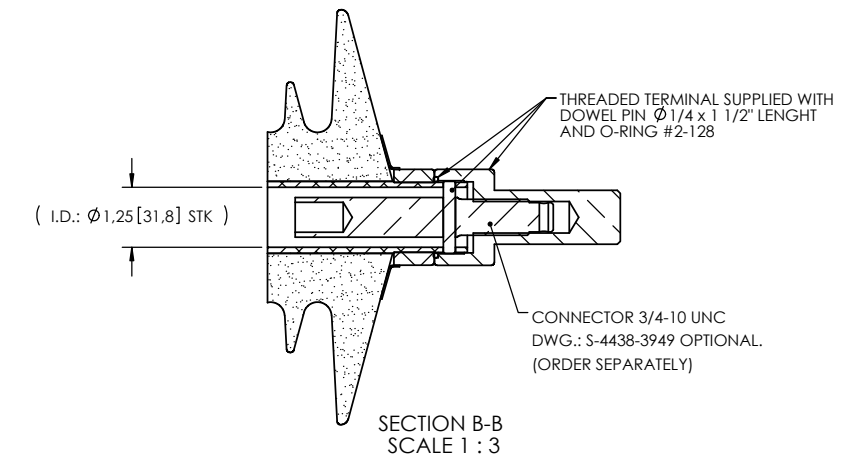
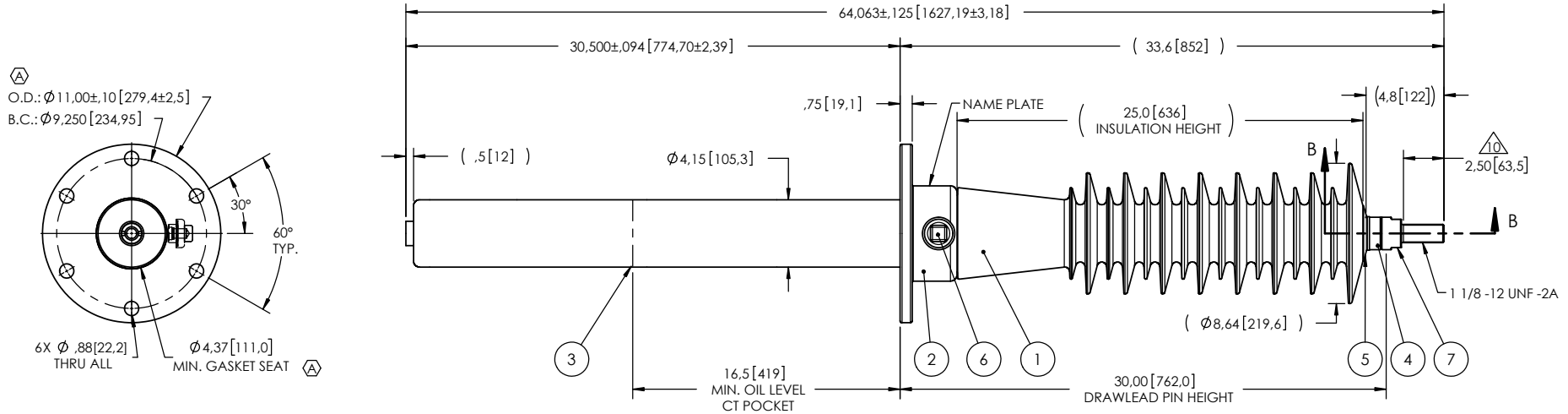

ITEM NO.	DRAWING NO.	PART NO.	DESCRIPTION	NOTE / MAT'L
7	1	S-6245-6112-1	THREADED TERMINAL KIT	COPPER
6	1	S-1001-2022	CAPACITANCE TAP ASSEMBLY	ALUMINUM
5	1	S-1344-0162-1	CAP	ALUMINUM
4	1	S-6630-6195	TUBE ASSEMBLY	ALUMINUM
3	1	S-6630-10097	SHIELD ASSEMBLY	COPPER
2	1	S-4922-4323	FLANGE	ALUMINUM
1	1	S-6630-6194	CASTING, CYCLOALIPHATIC RESIN	EC-APG-02

PARTS LIST				
GENERAL TOLERANCES (UNLESS OTHERWISE SPECIFIED)		EQUIVALENT TO:		<b>Electro Composites</b> <b>solid HV bushings solution</b> TITLE: $\triangle A$ SDC@ BUSHING 69kV, 400A MODEL:350-004-T-585-00
X.	$\pm 0.125$			
.X	$\pm 0.094$			
.XX	$\pm 0.063$			
.XXX	$\pm 0.031$			FORMAT: A CAGE CODE: DRAWING NO.: S-6630-6194 REVISION: A
ANGLES	$\pm .25^\circ$			SCALE: 1:10 GENERATED BY: SolidWorks 2009 SHEET: 1 of 1
RADIUS	$\pm 0.031$			
REMOVE BURRS AND BREAK SHARP EDGES				
DIMENSIONS ARE IN POUCCES (UNLESS OTHERWISE SPECIFIED)				

This drawing is the proprietary property of Electro Composites (2008) ULC, not part of the public domain, and is issued with the express understanding and agreement that it is not to be reproduced or copied in whole or in part or issued for furnishing information to others, or used directly or indirectly, in any way detrimental to the interest of Electro Composites (2008) ULC and is to be returned upon request by Electro Composites (2008) ULC. All Rights Reserved.