

T-BODY

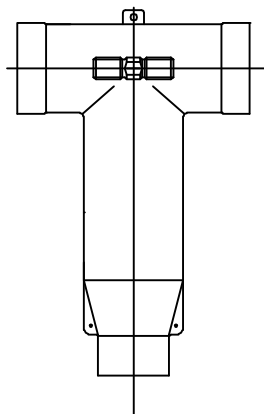

T-BODY WITH TESTPOINT

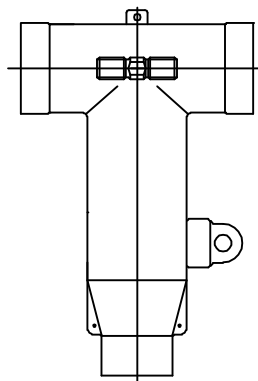

CABLE ADAPTER DIAMETER				
INSULATION Code "W"	Inches		MM	
	Min.	Max.	Min.	Min.
E	.530	.680	13.5	17.3
F	.640	.820	16.3	20.8
G	.760	.950	19.3	24.1
H	.850	1.050	21.6	26.7
J	.980	1.180	24.9	30.0
K	1.090	1.310	27.7	33.3
L	1.180	1.465	30.0	37.2
LM	1.280	1.430	32.5	36.3
M	1.370	1.630	34.8	41.4
N	1.515	1.780	38.5	45.2
P	1.725	1.935	43.8	49.1

TABLE W4

COMPRESSION CONNECTOR



CABLE ADAPTER

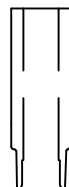

ELBOW TAP PLUG

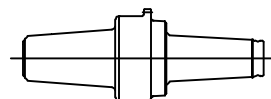

INSULATING CAP

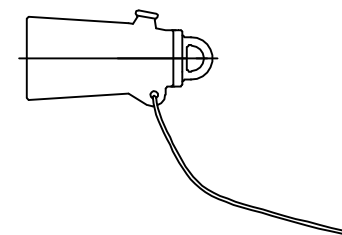

Conductor Code Chart		
Conductor Code "XX"	Concentric Compressed	Compact Solid
22	#2	#1
23	#1	1/0
24	1/0	2/0
25	2/0	3/0
26	3/0	4/0
27	4/0	250
28	250	300
29	300	350
30	350	400
31	400	450
32	450	500/550
33	500	600
34	550	650
35	600	700
36	650	750
38	700/750	900
39	800	-
40	900	1000
41	1000	-
44	1250	-

TABLE X5

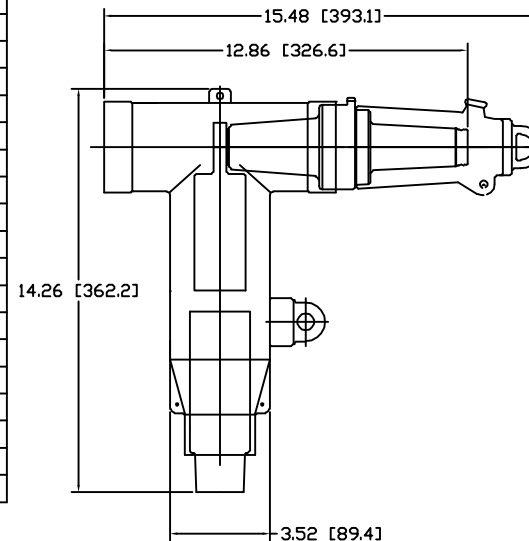

DIMENSIONS FOR REFERENCE ONLY
DIM: IN[MM]

DIM: IN[MM]

ORDERING INFORMATION

- 615ETPWXXTCJ
- W = INSULATION CODE FROM TABLE W4
- XX = CONDUCTOR CODE FROM TABLE X5
- T = ADD T FOR TEST POINT
- C = ADD C FOR INSULATING CAP
- J = ADD J FOR JACKET SEAL KIT

HUBBELL POWER SYSTEMS									
TITLE 615ETP SERIES 600A, 15KV ETP KIT									
CONFIDENTIAL: THIS DRAWING AND ITS CONTENTS ARE CONFIDENTIAL AND THE EXCLUSIVE PROPERTY OF HUBBELL POWER SYSTEMS. NO PUBLICATION, DISTRIBUTION OR COPIES MAY BE MADE WITHOUT THE WRITTEN CONSENT OF HUBBELL POWER SYSTEMS. HUBBELL POWER SYSTEMS UNPUBLISHED. ALL RIGHTS RESERVED UNDER THE COPYRIGHT LAWS.	<table border="1"> <tr> <td>SIZE</td> <td>DWG NO.</td> <td>CAT / PART / ASSY NO.</td> <td>REV</td> </tr> <tr> <td>BS</td> <td>--</td> <td>615ETPWXX</td> <td>0</td> </tr> </table>	SIZE	DWG NO.	CAT / PART / ASSY NO.	REV	BS	--	615ETPWXX	0
SIZE	DWG NO.	CAT / PART / ASSY NO.	REV						
BS	--	615ETPWXX	0						
DATE	01/23/13	DRN BY	JL						
DATE	01/23/13	SHEET	1 OF 1						