

NOTES:

- 1 CREEPAGE DISTANCE: 32.1" / 815mm
- 2 ARC DISTANCE: 13.0" / 330mm
- 3 NOMINAL VOLTAGE: 25kV
- 4 NOMINAL CURRENT: 400A
- 5 WITHSTAND VOLTAGE AT 60 sec.: 60kV
- 6 B.I.L. : 150kV
- 7 APPLICATION STANDARD: IEEE C57.19.01
- 8 MAX. TORQUE APPLIED ON FLANGE BOLTS: 40 lbf x ft/ 54.2k.N
- 9 WEIGHT: 43 lbs / 19.5 Kg

△10 SILVER PLATED TOP END, AS PER ASTM B700, TYPE 1, GRADE D, CLASS N, NO NICKEL LAYER, FROM 13 TO 20 MICROMETERS THICKNESS

△11 BLADE ORIENTATION WILL BE RANDOM

REVISIONS					
ZONE	REV.	DESCRIPTION	DRAWN BY	DATE	APPR.
C4 D1	A	THREADED TERMINAL CHANGE FROM S-6841-6442 TO S-6919-6634-1 SPADE WIDTH OF THE TERMINAL (-007) CHANGE FROM 1.50" TO 2.00"	J. CLICHE	2013-02-05	J.V.

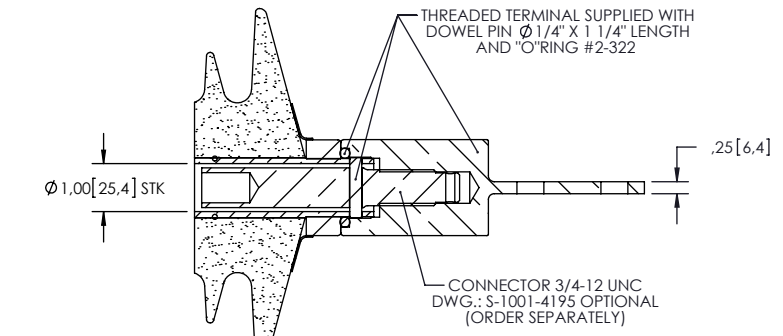
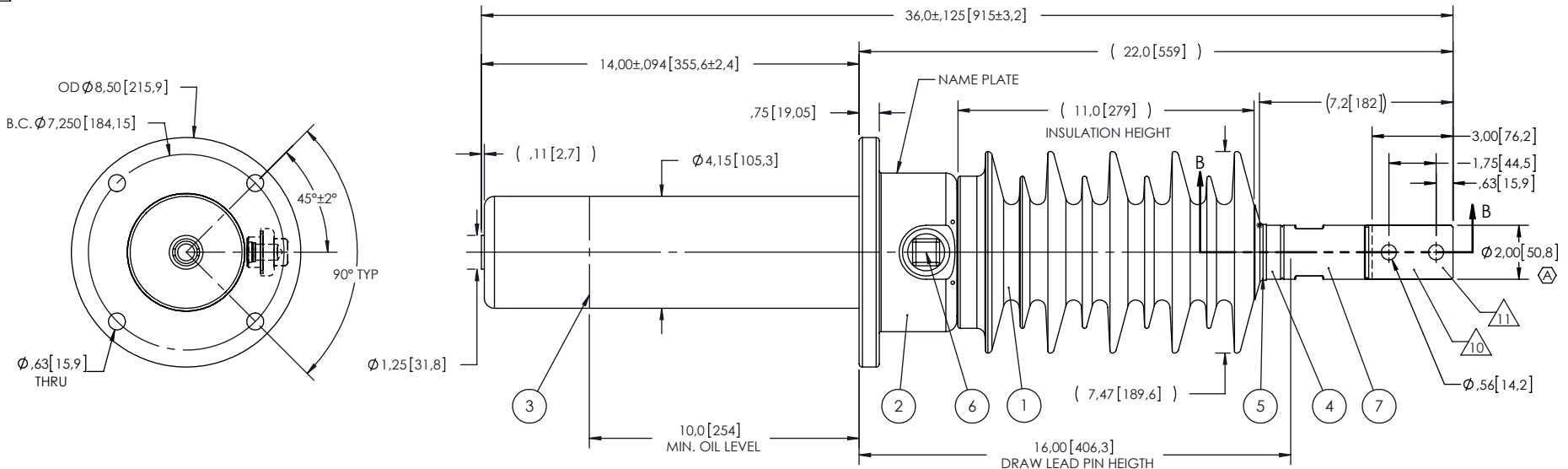

SECTION B-B
SCALE 1 : 4

ITEM NO.	QTY	DRAWING NO.	PART NO.	DESCRIPTION	NOTE / MATL
7	1	S-6919-6634-1		THREADED TERMINAL KIT	COPPER
6	1	S-1001-2022		CAPACITANCE TAP ASSEMBLY	ALUMINUM
5	1	S-1344-0162		CAP	COPPER
4	1	S-6841-6441		ROD ASSEMBLY	BRASS
3	1	S-6841-6440		SHIELD ASSEMBLY	COPPER
2	1	S-6841-6439		FLANGE	ALUMINUM
1	1	S-6841-6438	-001	CASTING, CYCLOALIPHATIC RESIN	EC-APG-02

PARTS LIST

GENERAL TOLERANCES (UNLESS OTHERWISE SPECIFIED) X. ±0.125 .X ±0.094 .XX ±0.063 .XXX ±0.010 ANGLES ±0.25° RADIUS ±0.031	REPLACE:	Electro Composites™ solid HV bushings solution			
	REMOVE BURRS AND BREAK SHARP EDGES DIMENSIONS ARE IN INCHES (UNLESS OTHERWISE SPECIFIED)	DRAWN BY: J.N.PILOTTE CHECK BY: PROJECT ENG.: PROJECT MANAGER:	DATE: 2011/03/11	TITLE: SDC® BUSHING 25kV, 400A MODEL: 150-004-T-617-00	
			FORMAT: A SCALE: 1:6	CAGE CODE: DRAWING NO.: S-6841-6438	REVISION: A SHEET: 1 of 1

This drawing is the proprietary property of Electro Composites (2008) ULC, not part of the public domain, and is issued with the express understanding and agreement that it is not to be reproduced or copied in whole or in part or issued for furnishing information to others, or used directly or indirectly, in any way detrimental to the interest of Electro Composites (2008) ULC and is to be returned upon request by Electro Composites (2008) ULC. All Rights Reserved.