

- NOTES:
- | | | |
|----|---|------------------------------------|
| 1 | CREEPAGE DISTANCE OUTSIDE: | 141.9" / 3604mm |
| 2 | ARC DISTANCE: | 48.1" / 223mm |
| 3 | NOMINAL VOLTAGE: | 115kV |
| 4 | NOMINAL CURRENT: | 1200A |
| 5 | VOLTAGE WITHSTAND, 60 sec.: | 260kV |
| 6 | B.I.L. : | 550kV |
| 7 | ROUTINE TEST ACCORDING TO: | IEEE C57.19.01 |
| 8 | MAX. TORQUE APPLIED ON FLANGE BOLTS: | 70 lbf x ft / 94.9 N.m \triangle |
| 9 | WEIGHT: | 315 lb / 142.9 kg |
| 10 | MAX. TORQUE APPLIED ON 3/4 NPT PIPE PLUG WITH TEFLON: | 35 lbf x ft |

REVISIONS					
ZONE	REV.	DESCRIPTION	DRAWN BY	DATE	APPR.
F5, E4, C5, B5	A	ADD THE MINIMUM GASKET SEAT DIMENSION. + ADD TOLERANCE ON THE EXTERNAL FLANGE DIAMETER + GENERAL UPDATE AS PER STANDARD	A.SAVARD	2018-03-02	J.V.

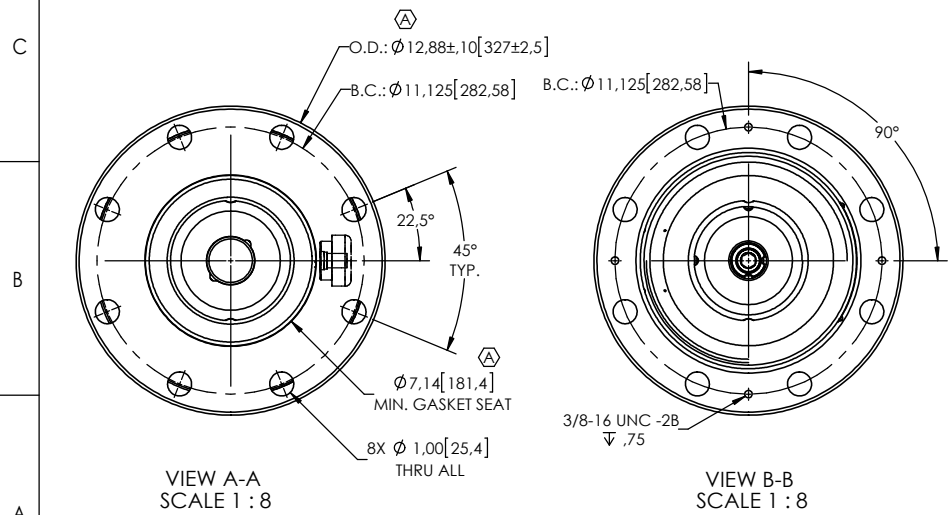
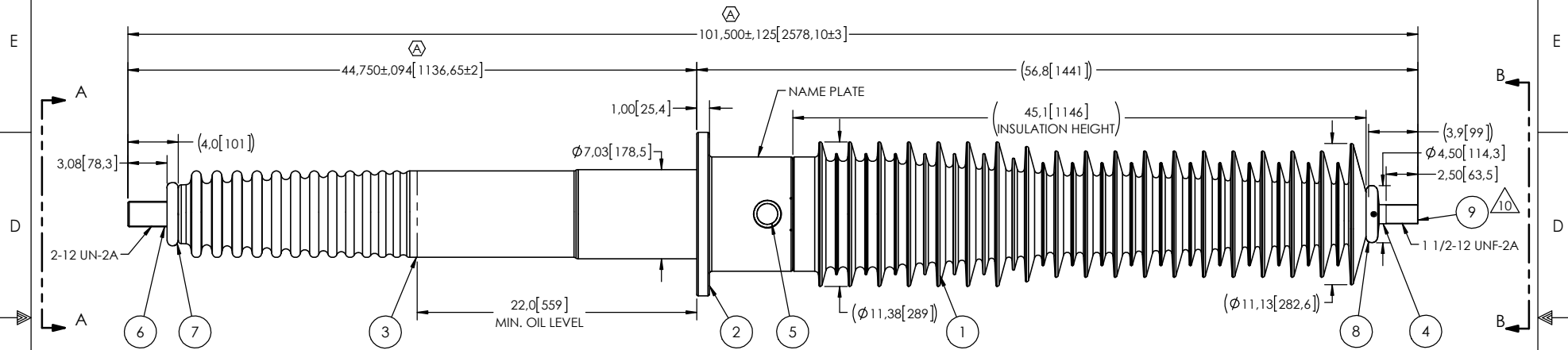

ITEM NO.	QTY	DRAWING NO.	PART NO.	DESCRIPTION	NOTE / MAT'L
9	1	S-1001-2465-322		3/4 NPT PIPE PLUG	BRASS
8	1	S-2878-4854		CORONA RING TOP	ALUMINUM
7	1	S-8140-7744		CORONA RING BOTTOM	ALUMINUM
6	1	S-8140-7743		TERMINAL TOP	COPPER
5	1	S-2878-2606		CAPACITANCE TAP ASSEMBLY	ALUMINUM
4	1	S-8140-7742		TUBE	COPPER
3	1	S-8140-7741		SHIELD ASSEMBLY	BRASS
2	1	S-8140-7740		FLANGE	ALUMINUM
1	1	S-8140-7739	-001	CASTING, CYCLOALIPHATIC RESIN	EC-APG-02

PARTS LIST					
GENERAL TOLERANCES (UNLESS OTHERWISE SPECIFIED)			ElectroComposites solid HV bushings solution		
X.	±0.125				
.X	±0.094		TITLE: SDC® BUSHING 115kV, 1200A MODEL: 550-012-B-650-01		
.XX	±0.063		DRAWN BY: A.SAVARD DATE: 2013/01/21		
.XXX	±0.010		PROJECT NO.: []		
ANGLES	±0.25°		FORMAT: A CAGE CODE: [] DRAWING NO.: S-8140-7739 REVISION: A		
RADIUS	±0.031		PROJECT MANAGER: [] SCALE: 1:12 GENERATED BY: SolidWorks 2013 SHEET: 1 of 1		
REMOVE BURRS AND BREAK SHARP EDGES					
DIMENSIONS ARE IN INCHES (UNLESS OTHERWISE SPECIFIED)					

This drawing is the proprietary property of Electro Composites (2008) ULC, not part of the public domain, and is issued with the express understanding and agreement that it is not to be reproduced or copied in whole or in part or issued for furnishing information to others, or used directly or indirectly, in any way detrimental to the interest of Electro Composites (2008) ULC and is to be returned upon request by Electro Composites (2008) ULC. All Rights Reserved.