

- NOTES:
- 1 CREEPAGE DISTANCE: 1282 mm/50.5"
 - 2 ARC DISTANCE: 545 mm/21.5"
 - 3 NOMINAL VOLTAGE: 34.5kV
 - 4 NOMINAL CURRENT: 4000A
 - 5 WITHSTAND VOLTAGE AT 60 sec.: 80kV
 - 6 B.I.L. : 200kV
 - 7 ROUTINE TEST ACCORDING TO IEEE C57.19.01
 - 8 MAX. TORQUE APPLIED ON FLANGE BOLTS: 70 lbf x ft
 - 9 WEIGHT: 114.8 Kg / 252 lbs \triangle
- \triangle SILVER PLATED, AS PER ASTM B700, TYPE 1, GRADE D, CLASS N, NO NICKEL LAYER, FROM 13 TO 20 MICROMETERS THICKNESS

| REVISIONS | | | | | |
|-----------|------|---|----------|------------|-------|
| ZONE | REV. | DESCRIPTION | DRAWN BY | DATE | APPR. |
| | A | WEIGHT HAS BEEN CHANGED ACCORDING TO AN IMPROVED DESIGN | A.SAVARD | 2012/02/22 | Y.V. |

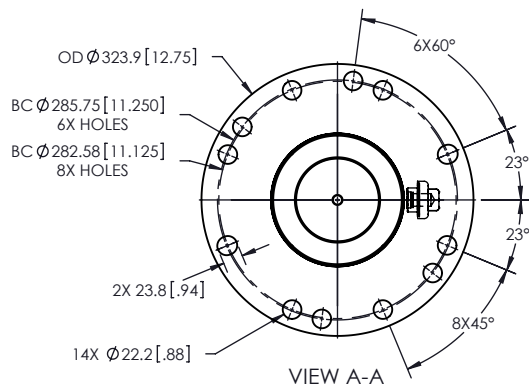
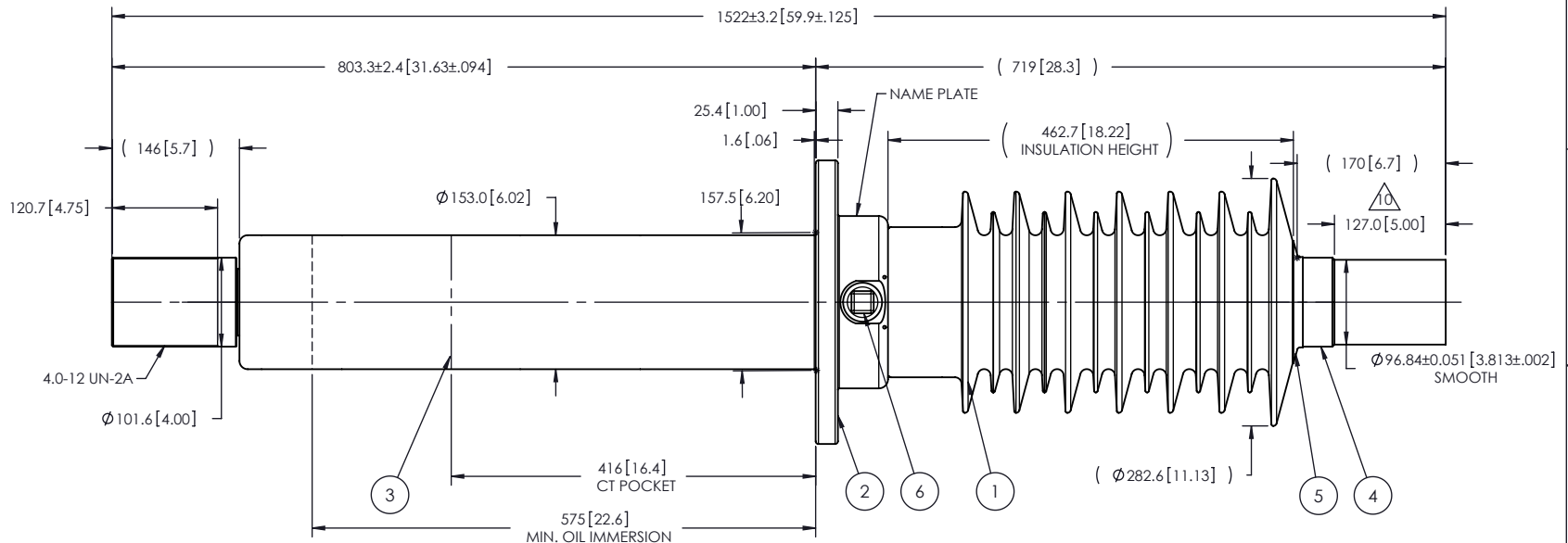

This drawing is the proprietary property of Electro Composites (2008) ULC, not part of the public domain, and is issued with the express understanding and agreement that it is not to be reproduced or copied in whole or in part or issued for furnishing information to others, or used directly or indirectly, in any way detrimental to the interest of Electro Composites (2008) ULC and is to be returned upon request by Electro Composites (2008) ULC. All Rights Reserved.

| ITEM NO. | QTY | DRAWING NO. | PART NO. | DESCRIPTION | NOTE / MAT'L |
|----------|-----|-------------|----------|-------------------------------|--------------|
| 6 | 1 | S-1001-2022 | | CAPACITANCE TAP ASSEMBLY | ALUMINUM |
| 5 | 1 | S-3974-3543 | | CAP | COPPER |
| 4 | 1 | S-7288-7014 | | ROD ASSEMBLY | COPPER |
| 3 | 1 | S-7288-7013 | | SHIELD ASSEMBLY | COPPER |
| 2 | 1 | S-7288-7012 | | FLANGE | ALUMINUM |
| 1 | 1 | S-7288-7011 | -001 | CASTING, CYCLOALIPHATIC RESIN | EC-APG-02 |

| PARTS LIST | | | | | |
|---|-------|---|---|--------------------------|-------------|
| GENERAL TOLERANCES (UNLESS OTHERWISE SPECIFIED) | | | Electro Composites™ solid HV bushings solution | | |
| X. | ±3.2 | TITLE: BUSHING 34.5kV, 4000A MODEL: 200-040-T-689-00 | | | |
| .X | ±2.4 | | DRAWN BY: A.SAVARD DATE: 2012/01/18 | | |
| .XX | ±1.6 | REMOVE BURRS AND BREAK SHARP EDGES | | | |
| .XXX | ±0.8 | DIMENSIONS ARE IN MILLIMETERS (UNLESS OTHERWISE SPECIFIED) | | | |
| ANGLES | ±1.0° | PROJECT ENG.: | | | |
| RADIUS | ±1.6 | PROJECT MANAGER: | | | |
| SCALE: 1:8 | | FORMAT: A | CAGE CODE: | DRAWING NO.: S-7288-7011 | REVISION: A |
| GENERATED BY: SolidWorks 2009 | | SHEET: 1 of 1 | | | |