

- NOTES:
- 1 CREEPAGE DISTANCE: 18.9" / 480mm
  - 2 ARC DISTANCE: 8.8" / 224mm
  - 3 NOMINAL VOLTAGE: 15kV
  - 4 NOMINAL CURRENT: 1300A
  - 5 WITHSTAND VOLTAGE AT 60 sec.: 50kV
  - 6 B.I.L. : 110kV
  - 7 APPLICATION STANDARD: IEEE C57.19.01
  - 8 MAX. TORQUE APPLIED ON FLANGE BOLTS: 40 lbf x ft
  - 9 WEIGHT: 26.6 lb / 12.07 Kg

REVISIONS					
ZONE	REV.	DESCRIPTION	DRAWN BY	DATE	APPR.

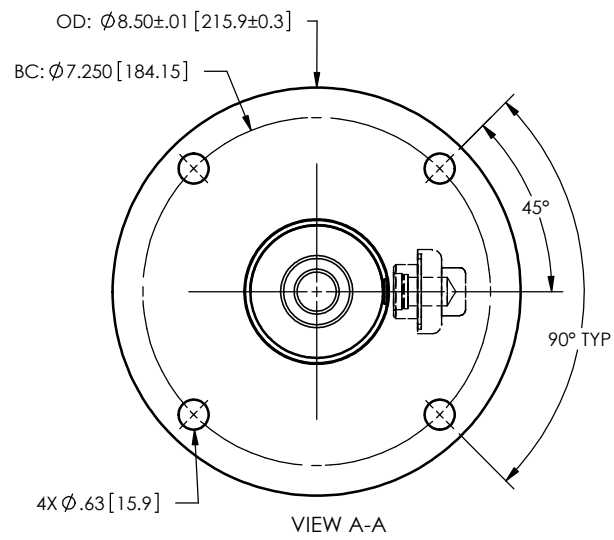
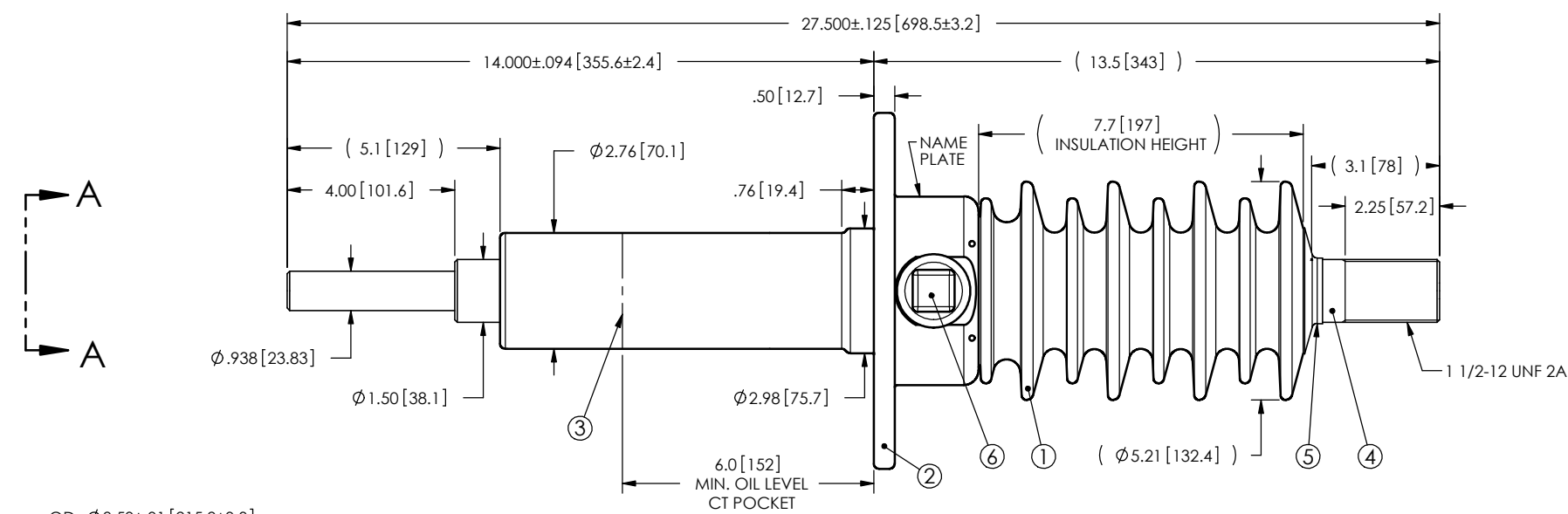

This drawing is the proprietary property of Electro Composites (2008) ULC, not part of the public domain, and is issued with the express understanding and agreement that it is not to be reproduced or copied in whole or in part or issued for furnishing information to others, or used directly or indirectly, in any way detrimental to the interest of Electro Composites (2008) ULC and is to be returned upon request by Electro Composites (2008) ULC. All Rights Reserved.

ITEM NO.	QTY	DRAWING NO.	PART NO.	DESCRIPTION	NOTE / MAT'L
6	1	S-1001-2022		CAPACITANCE TAP ASSEMBLY	ALUMINUM
5	1	S-1001-0007		CAP	COPPER
4	1	S-8388-8905		ROD ASSEMBLY	COPPER
3	1	S-7484-7021		SHIELD ASSEMBLY	COPPER
2	1	S-7484-7020		FLANGE	ALUMINUM
1	1	S-8388-8904	-001	CASTING, CYCLOALIPHATIC RESIN	EC-APG-02

PARTS LIST					
GENERAL TOLERANCES (UNLESS OTHERWISE SPECIFIED)		REPLACE:		<b>Electro Composites</b> <b>solid HV bushings solution</b>	
X.	±0.125				
.X	±0.094			TITLE: BUSHING 15kV, 1300A MODEL: 110-013-T-690-01	
.XX	±0.063			DRAWING NO. S-8388-8904	
.XXX	±0.010			REVISION NR	
ANGLES	±0.1°			SCALE 1:4	
RADIUS	±0.031			GENERATED BY: SolidWorks 2013	
REMOVE BURRS AND BREAK SHARP EDGES		DIMENSIONS ARE IN INCHES (UNLESS OTHERWISE SPECIFIED)		SHEET 1 of 1	