

- NOTES:
- 1 CREEPAGE DISTANCE: 18.4" / 467mm
 - 2 ARC DISTANCE: 8.3" / 211mm
 - 3 NOMINAL VOLTAGE: 15kV
 - 4 NOMINAL CURRENT: 400A
 - 5 VOLTAGE WITHSTAND, 60 sec.: 50kV
 - 6 BIL : 110kV
 - 7 ROUTINE TEST ACCORDING TO: CSA C88.1-96
 - 8 MAX. TORQUE APPLIED ON FLANGE BOLTS: 40 lbf·ft / 54.2 N·m
 - 9 WEIGHT: 33 lb / 15.9 Kg

REVISIONS					
ZONE	REV.	DESCRIPTION	DRAWN BY	DATE	APPR.
E6 C6	A	INCREASE THE TOLERANCES ON THE FLANGE OUTSIDE DIAMETER. ADD THE MINIMUM GASKET SEAT DIMENSION.	J. CLICHE	2017-05-24	Y.V.

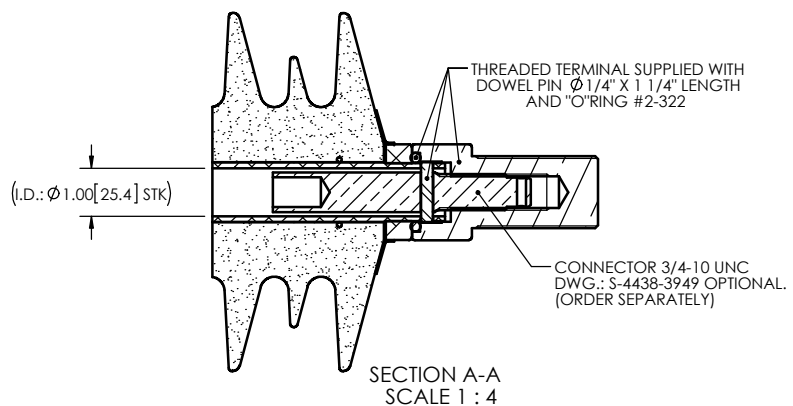
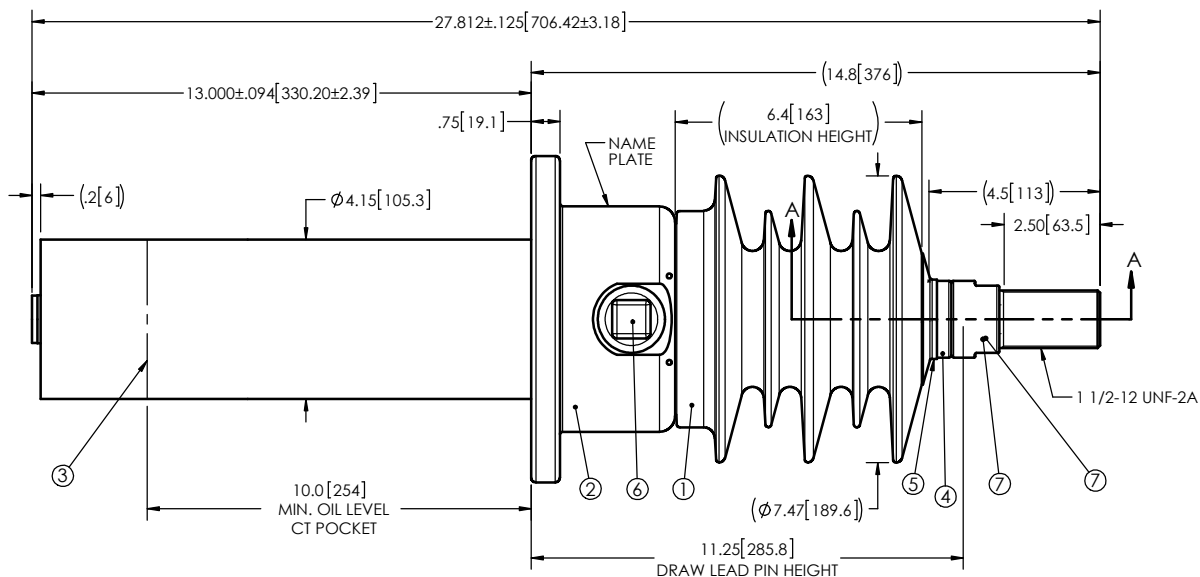
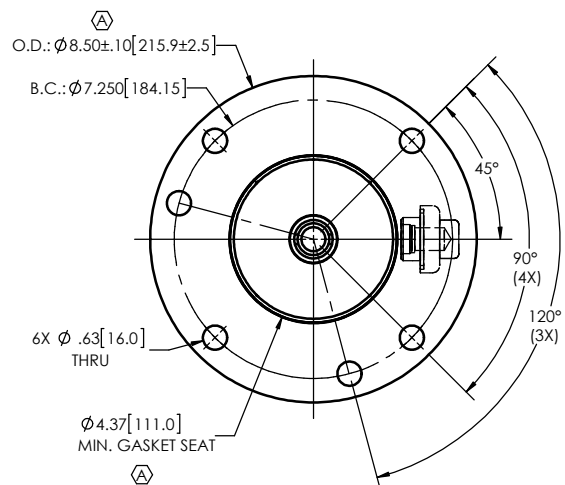

ITEM NO.	QTY	DRAWING NO.	PART NO.	DESCRIPTION	NOTE / MAT'L
7	1	S-4831-4209-0		THREADED TERMINAL KIT	COPPER
6	1	S-1001-2022		CAPACITANCE TAP ASSEMBLY	ALUMINUM
5	1	S-1344-0162-1		CAP	ALUMINUM
4	1	S-7669-7491		DRAWLEAD ASSEMBLY	ALUMINUM
3	1	S-7669-7490		SHIELD ASSEMBLY	COPPER
2	1	S-7669-7489		FLANGE	ALUMINUM
1	1	S-7669-7488	-001	CASTING, CYCLOALIPHATIC RESIN	EC-APG-02

PARTS LIST

GENERAL TOLERANCES (UNLESS OTHERWISE SPECIFIED)

X.	± 0.125
.X	± 0.094
.XX	± 0.063
.XXX	± 0.031
ANGLES	$\pm 0.25^\circ$
RADIUS	± 0.031

REMOVE BURRS AND BREAK SHARP EDGES

DIMENSIONS ARE IN INCHES (UNLESS OTHERWISE SPECIFIED)

DRAWN BY:		DATE:		TITLE:	
J.N.PILOTTE		2012/09/18		SDC [®] BUSHING 15kV, 400A MODEL: 110-004-T-759-00	
FORMAT:	CAGE CODE:	DRAWING NO.:	REVISION:		
A		S-7669-7488	A		
SCALE:	GENERATED BY:	SHEET:			
1:5	SolidWorks 2013	1 of 1			

This drawing is the proprietary property of Electro Composites (2008) ULC, not part of the public domain, and is issued with the express understanding and agreement that it is not to be reproduced or copied in whole or in part or issued for furnishing information to others, or used directly or indirectly, in any way detrimental to the interest of Electro Composites (2008) ULC and is to be returned upon request by Electro Composites (2008) ULC. All Rights Reserved.