

NOTES:

- 1 CREEPAGE DISTANCE: 82.0" / 2083mm
- 2 ARC DISTANCE: 36.6" / 924mm
- 3 NOMINAL VOLTAGE: 69kV
- 4 NOMINAL CURRENT: 1200A
- 5 WITHSTAND VOLTAGE AT 60 sec.: 160kV
- 6 B.I.L.: 350kV
- 7 ROUTINE TEST ACCORDING TO: IEEE C57.19.01
- 8 MAX. TORQUE APPLIED ON FLANGE BOLTS: 40 lbf X ft
- 9 WEIGHT: 109 lb / 49.5 Kg

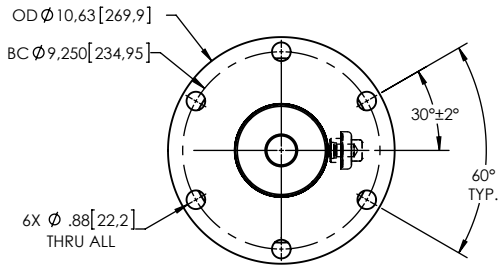
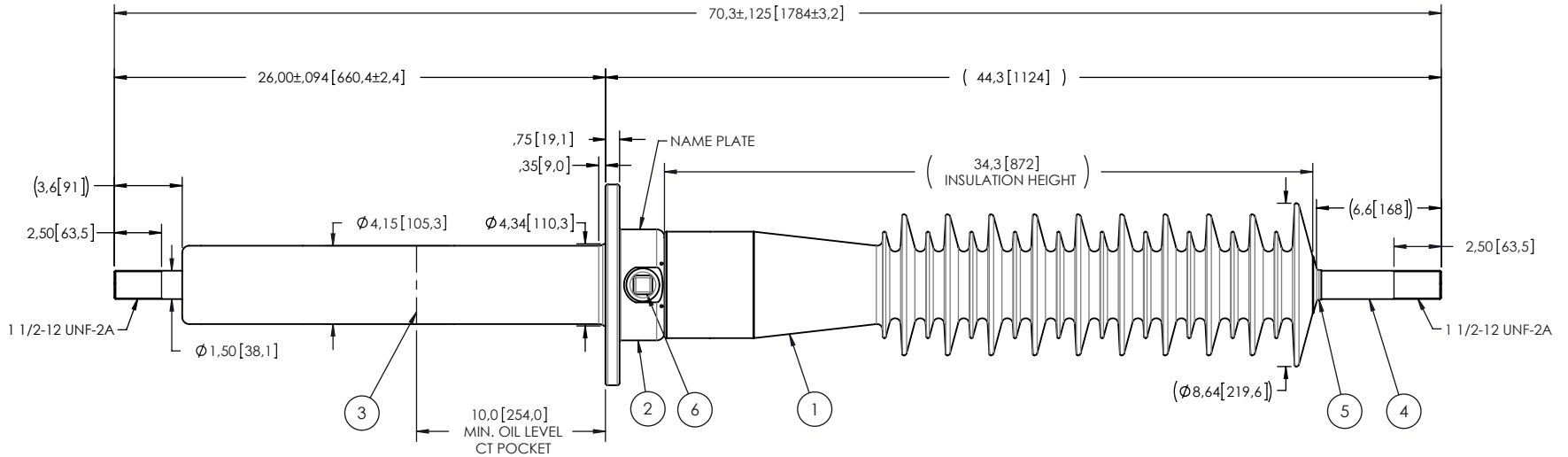

VIEW A-A

This drawing is the proprietary property of Electro Composites (2008) ULC, not part of the public domain, and is issued with the express understanding and agreement that it is not to be reproduced or copied in whole or in part or issued for furnishing information to others, or used directly or indirectly, in any way detrimental to the interest of Electro Composites (2008) ULC and is to be returned upon request by Electro Composites (2008) ULC. All Rights Reserved.

ITEM NO.	QTY	DRAWING NO.	PART NO.	DESCRIPTION	NOTE / MAT'L
6	1	S-1001-2022		CAPACITANCE TAP ASSEMBLY	ALUMINUM
5	1	S-1001-0007		CAP	COPPER
4	1	S-8140-7691		ROD ASSEMBLY	COPPER
3	1	S-5390-5064		SHIELD ASSEMBLY	COPPER
2	1	S-5172-4704		FLANGE	ALUMINUM
1	1	S-8140-7689	-001	CASTING, CYCLOALIPHATIC RESIN	EC-APG-02

PARTS LIST

GENERAL TOLERANCES (UNLESS OTHERWISE SPECIFIED)

X.	±0.125
.X	±0.094
.XX	±0.063
.XXX	±0.010
ANGLES	±0.25°
RADIUS	0.031

REMOVE BURRS AND BREAK SHARP EDGES

DIMENSIONS ARE IN INCHES (UNLESS OTHERWISE SPECIFIED)

DRAWN BY: A.SAVARD	DATE: 2012/12/13
CHECK BY:	
PROJECT ENG.:	
PROJECT MANAGER:	

Electro Composites
solid HV bushings solution

TITLE:
SDC® BUSHING 69kV, 1200A
MODEL: 350-012-T-786-00

FORMAT A	CAGE CODE	DRAWING NO. S-8140-7689	REVISION NR
-------------	-----------	----------------------------	----------------

SCALE 1 : 10	GENERATED BY: SolidWorks 2012	SHEET 1 of 1
-----------------	----------------------------------	-----------------