

LIST OF PARTS

DESCRIPTION	MATERIAL	FINISH
COVER	STEEL	GALVANIZED
INSERTS	STEEL	GALVANIZED
SCREWS	STEEL	GALVANIZED
NUTS	STEEL	GALVANIZED

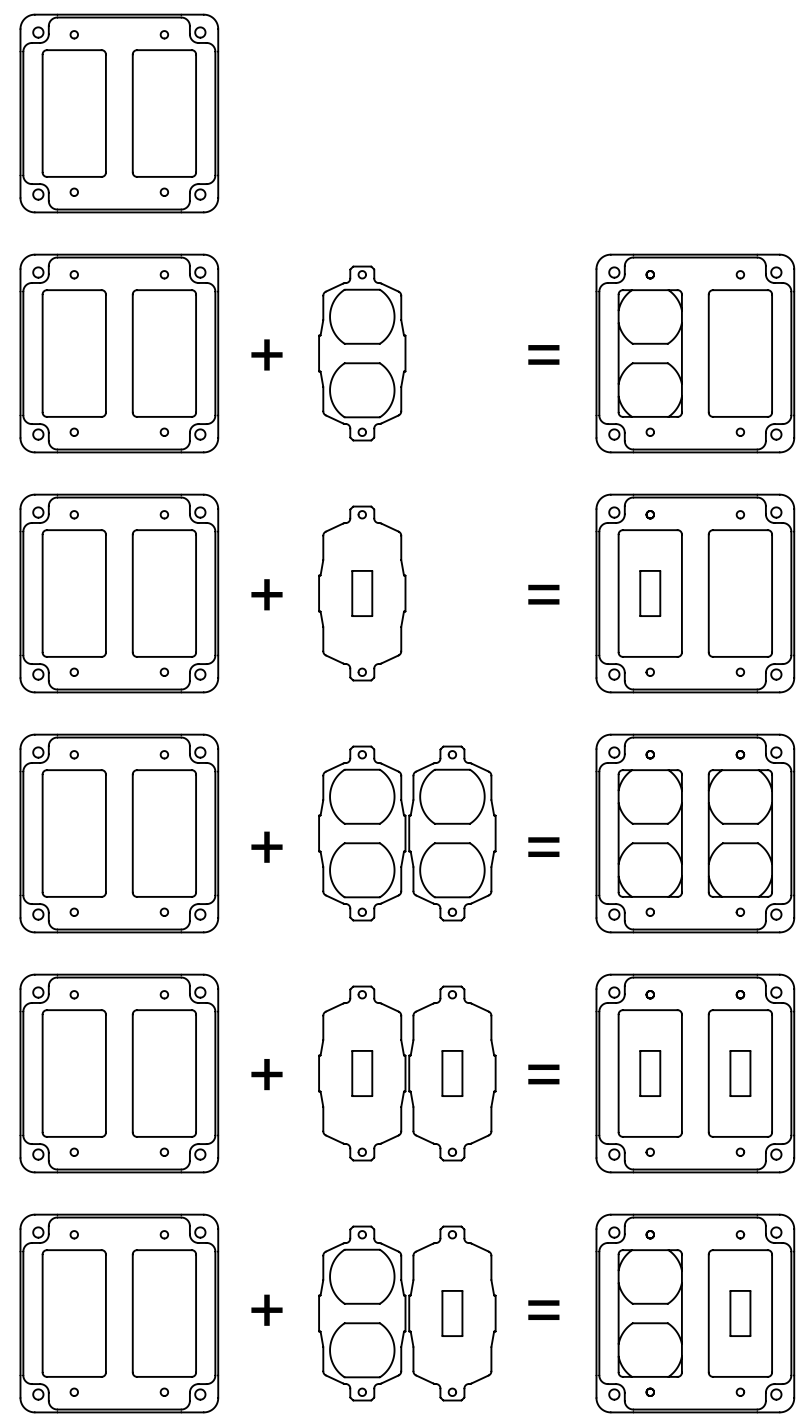

POSSIBLE ASSEMBLY COMBINATIONS

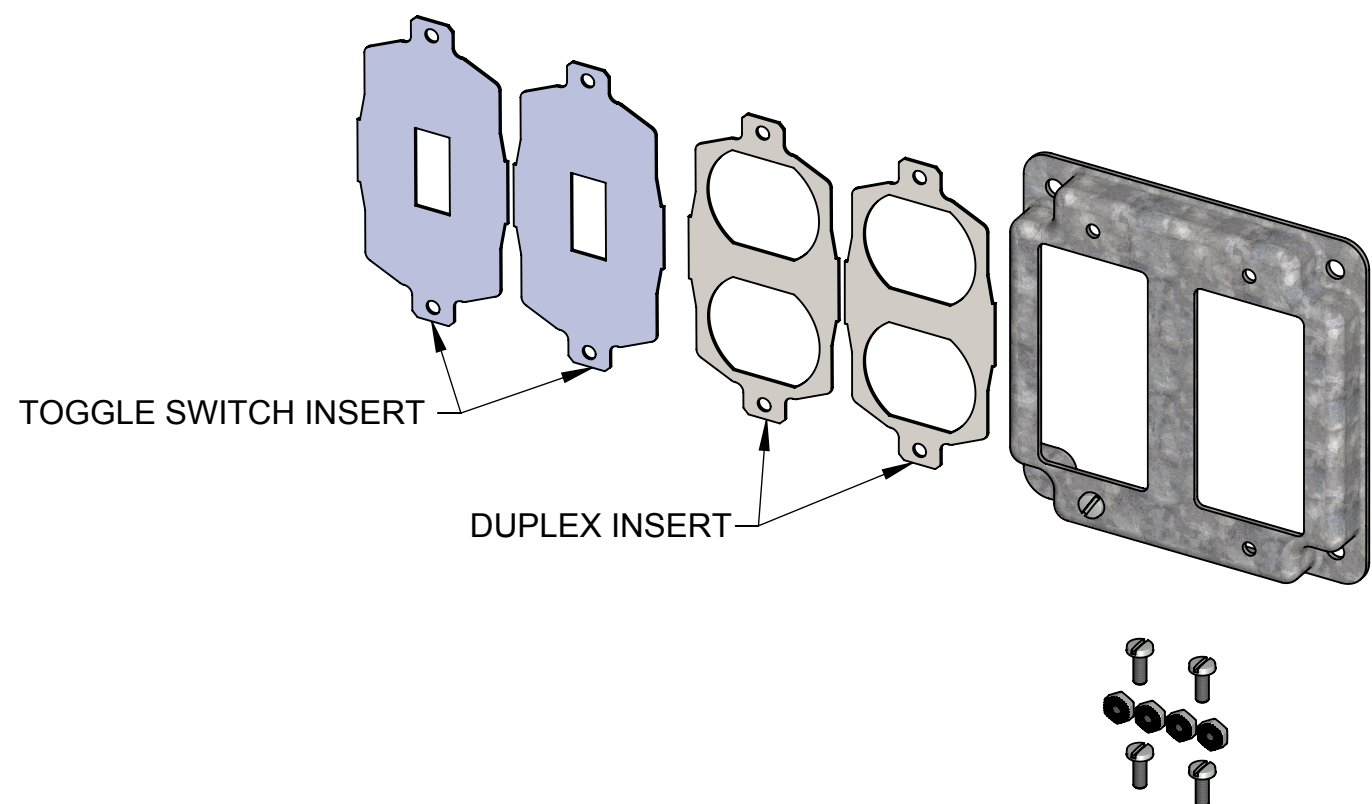
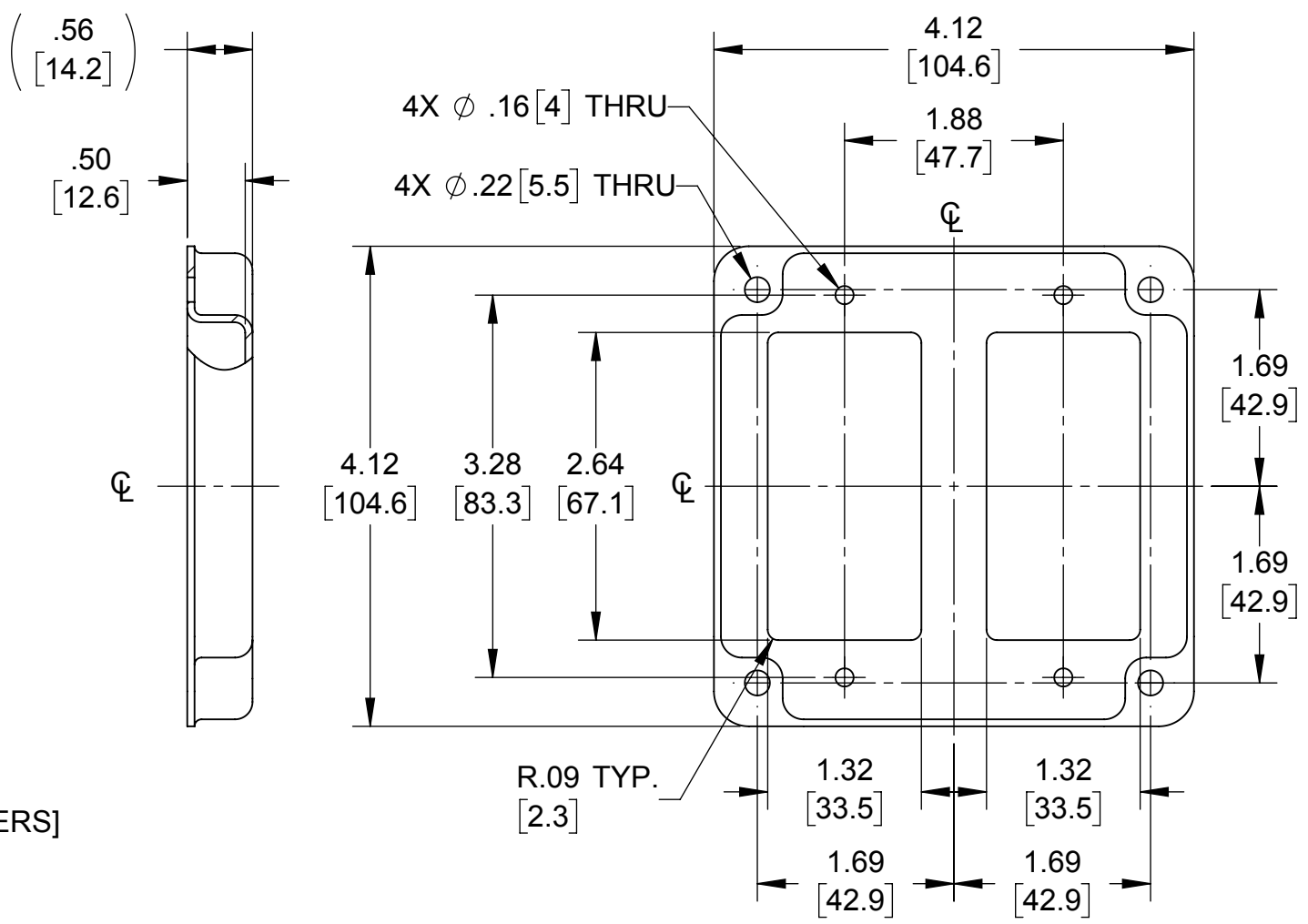

- NOTES:
 1. ALL DIMENSIONS ARE IN INCHES AND [MILLIMETERS]
 2. BOX VOLUME: 6.5 IN³ [107] CM³
 3. UL LISTED

SYM.	REVISION DESCRIPTION	APP	DATE
	INITIAL RELEASE	RMV	07-31-17

THE DESIGN AND DIMENSIONS OF THE PRODUCT SHOWN ON THIS DRAWING ARE SUBJECT TO CHANGE WITHOUT NOTICE

TITLE:
4" SQ. CRUSHED CORNER COVER, (2) GFCI

TOLERANCE UNLESS OTHERWISE SPECIFIED .XX DECIMAL ±.015 .XXX DECIMAL ±.005 ANGLE ±2°			RACO South Bend, Indiana	SIZE: B
DRAWN BY:	RMV	SCALE:	1:1.5	
APP. BY:	N.S.	DATE:	07-31-17	