

3/4-10 UFS-2B TAPPED HOLE
PER ANSI C29.7

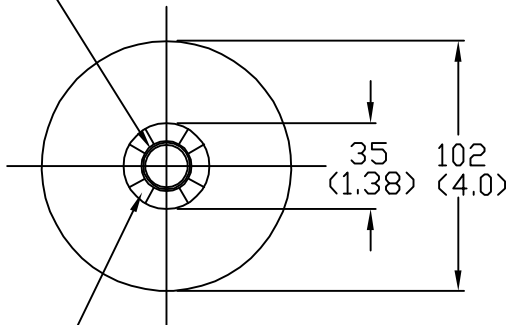

CAST IN SERRATED LOCKING
PAD PER ANSI C29.7

VIEW A-A
2X SCALE

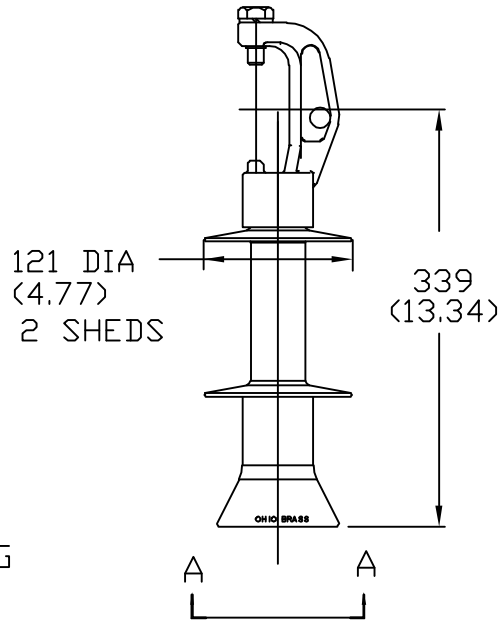

DRY ARCING DISTANCE _____	188 MM (7.4 IN)
LEAKAGE DISTANCE _____	279 MM (11.0 IN)
60 Hz DRY FLASHOVER _____	90 kV
60 Hz WET FLASHOVER _____	70 kV
IMPULSE POS. CRITICAL FLASHOVER _____	150 kV
IMPULSE POS. WITHSTAND _____	140 kV
SCL _____	12.5 kN (2800 LB)
RCL _____	5.5 kN (1235 LB)
NET WEIGHT _____	3.1 KG (6.9 LB.)

OHIO BRASS
TOLERANCE CHART



HUBBELL POWER SYSTEMS

CONFIDENTIAL: THIS DRAWING AND ITS CONTENTS ARE CONFIDENTIAL AND THE EXCLUSIVE PROPERTY OF HUBBELL POWER SYSTEMS. NO PUBLICATION, DISTRIBUTION OR COPIES MAY BE MADE WITHOUT THE WRITTEN CONSENT OF HUBBELL POWER SYSTEMS. HUBBELL POWER SYSTEMS UNPUBLISHED ALL RIGHTS RESERVED UNDER THE COPYRIGHT LAWS.

TITLE
VERI LITE
15 KV LINE POST

REV DATE 08/21/07

SIZE S	DWG NO. --	CAT / PART / ASSY NO. 80S015-0109	REV 2
-----------	---------------	--------------------------------------	----------

DO NOT SCALE THIS DRAWING	DRN BY JVR	DATE 08/31/05	SHEET 1 OF 1
---------------------------	------------	---------------	--------------