

3/4-10 UFS-2B TAPPED HOLE
PER ANSI C29.7

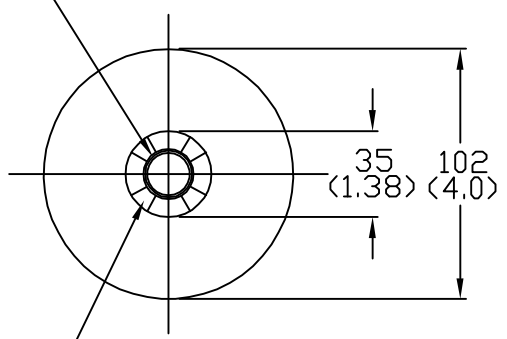

CAST IN SERRATED LOCKING
PAD PER ANSI C29.7

VIEW A-A
2X SCALE

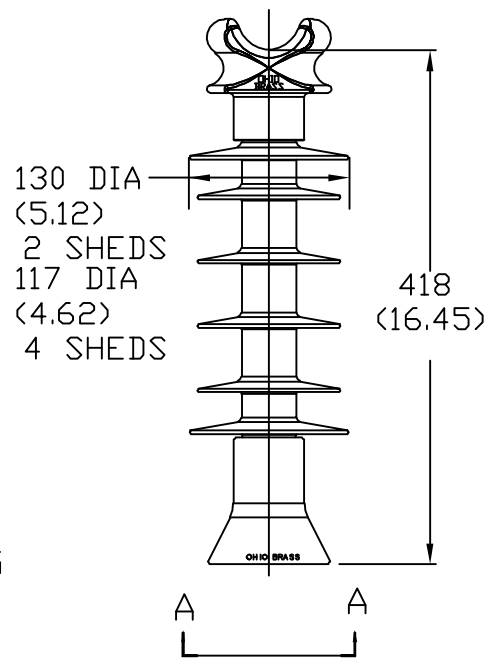

| | |
|--|--------------------|
| DRY ARCING DISTANCE _____ | 297 MM (11.7 IN) |
| LEAKAGE DISTANCE _____ | 662 MM (26.1 IN) |
| 60 Hz DRY FLASHOVER _____ | 135 kV |
| 60 Hz WET FLASHOVER _____ | 100 kV |
| IMPULSE POS. CRITICAL: FLASHOVER _____ | 215 kV |
| IMPULSE POS. WITHSTAND _____ | 200 kV |
| SCL _____ | 12.5 kN (2800 LB.) |
| RCL _____ | 5.5 kN (1235 LB.) |
| NET WEIGHT _____ | 3.6 KG (7.9 LB.) |

OHIO BRASS
TOLERANCE CHART



HUBBELL POWER SYSTEMS

CONFIDENTIAL: THIS DRAWING AND ITS CONTENTS ARE CONFIDENTIAL AND THE EXCLUSIVE PROPERTY OF HUBBELL POWER SYSTEMS. NO PUBLICATION, DISTRIBUTION OR COPIES MAY BE MADE WITHOUT THE WRITTEN CONSENT OF HUBBELL POWER SYSTEMS. HUBBELL POWER SYSTEMS UNPUBLISHED ALL RIGHTS RESERVED UNDER THE COPYRIGHT LAWS.

TITLE
VERI LITE
35 KV LINE POST

REV DATE 08/21/07

| | | | |
|---------------------------|---------------|--------------------------------------|--------------|
| SIZE S | DWG NO. -- | CAT / PART / ASSY NO. 80S028-0F09 | REV 3 |
| DO NOT SCALE THIS DRAWING | DRN BY JVR | DATE 08/31/05 | SHEET 1 OF 1 |