

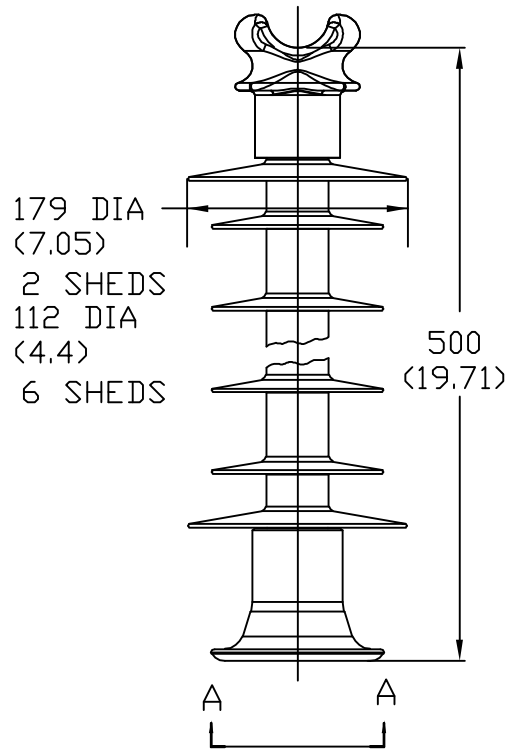

VIEW A-A
2X SCALE



DRY ARCING DISTANCE	_____	390 MM (14.4 IN)
LEAKAGE DISTANCE	_____	872 MM (34.3 IN)
60 Hz DRY FLASHOVER	_____	170 kV
60 Hz WET FLASHOVER	_____	125 kV
IMPULSE POS. CRITICAL FLASHOVER	_____	260 kV
IMPULSE POS. WITHSTAND	_____	235 kV
SCL	_____	12.5 kN (2800 LB.)
RCL	_____	5.5 kN (1235 LB.)
NET WEIGHT	_____	6.3 KG (13.9 LB.)

CONFIDENTIAL: THIS DRAWING AND ITS CONTENTS ARE CONFIDENTIAL AND THE EXCLUSIVE PROPERTY OF HUBBELL POWER SYSTEMS. NO PUBLICATION, DISTRIBUTION OR COPIES MAY BE MADE WITHOUT THE WRITTEN CONSENT OF HUBBELL POWER SYSTEMS. HUBBELL POWER SYSTEMS UNPUBLISHED ALL RIGHTS RESERVED UNDER THE COPYRIGHT LAWS.	 HUBBELL® POWER SYSTEMS			
	TITLE VERI LITE 46 KV LINE POST			
REV DATE	SIZE	DWG NO.	CAT / PART / ASSY NO.	REV
01/31/17	S	--	80S046-0F09	4
DO NOT SCALE THIS DRAWING		DRN BY JVR	DATE 09/01/05	SHEET 1 OF 1