

**LIST OF PARTS**

DESCRIPTION	MATERIAL	FINISH
COVER	STEEL	GALVANIZED
SCREWS	STEEL	GALVANIZED

#6-32 X 5/16" TRUSS HEAD  
MACHINE SCREWS (QTY.2)

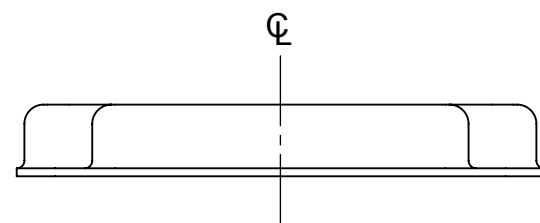
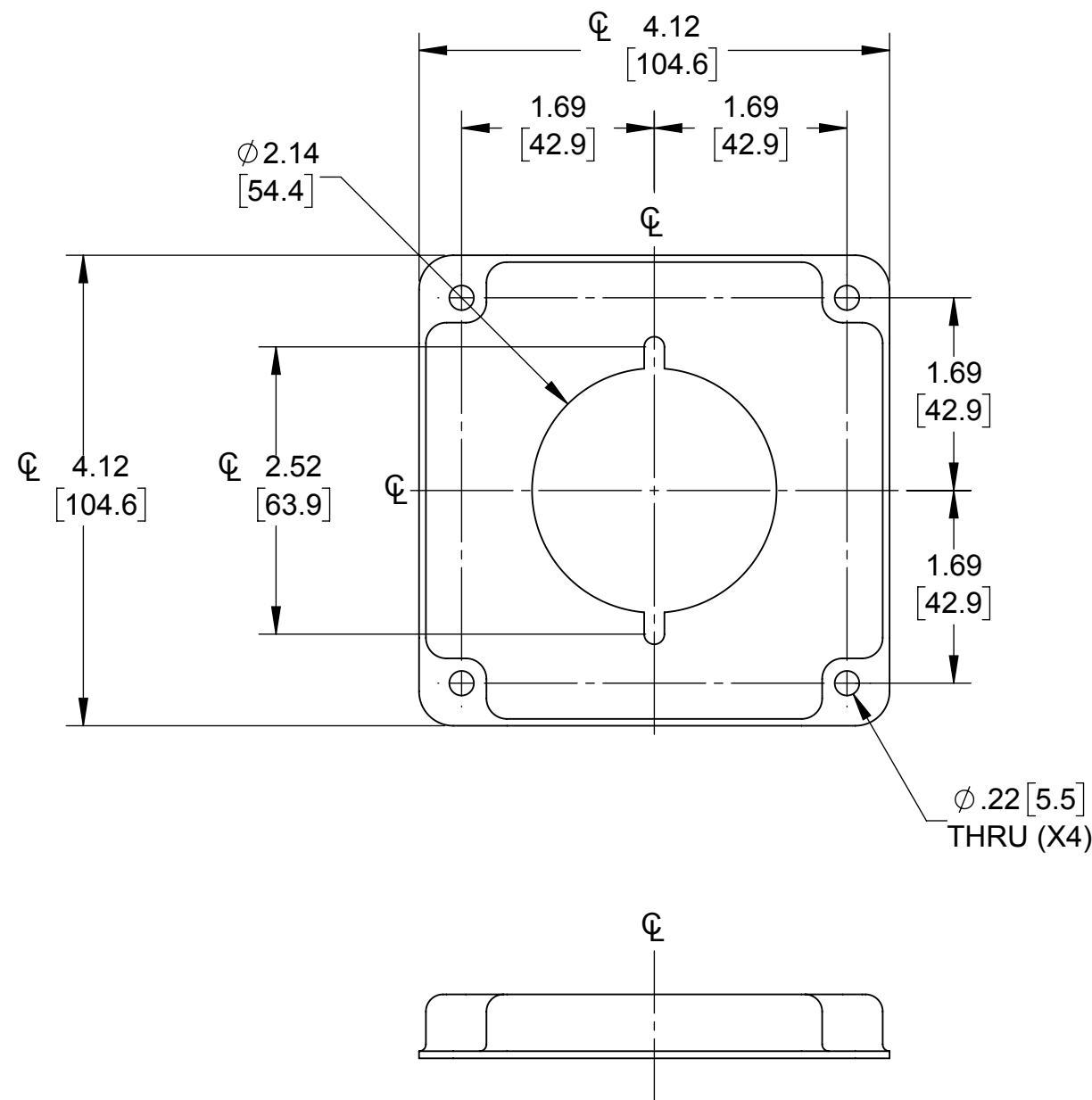
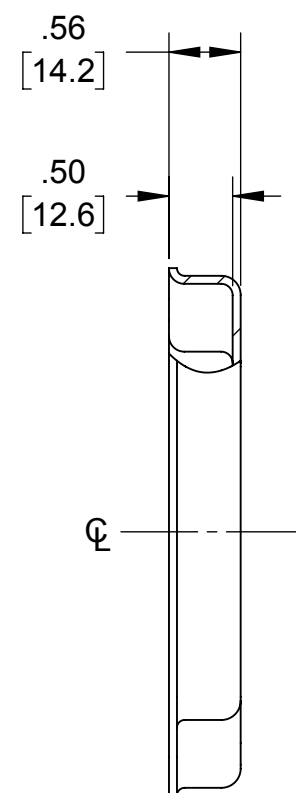
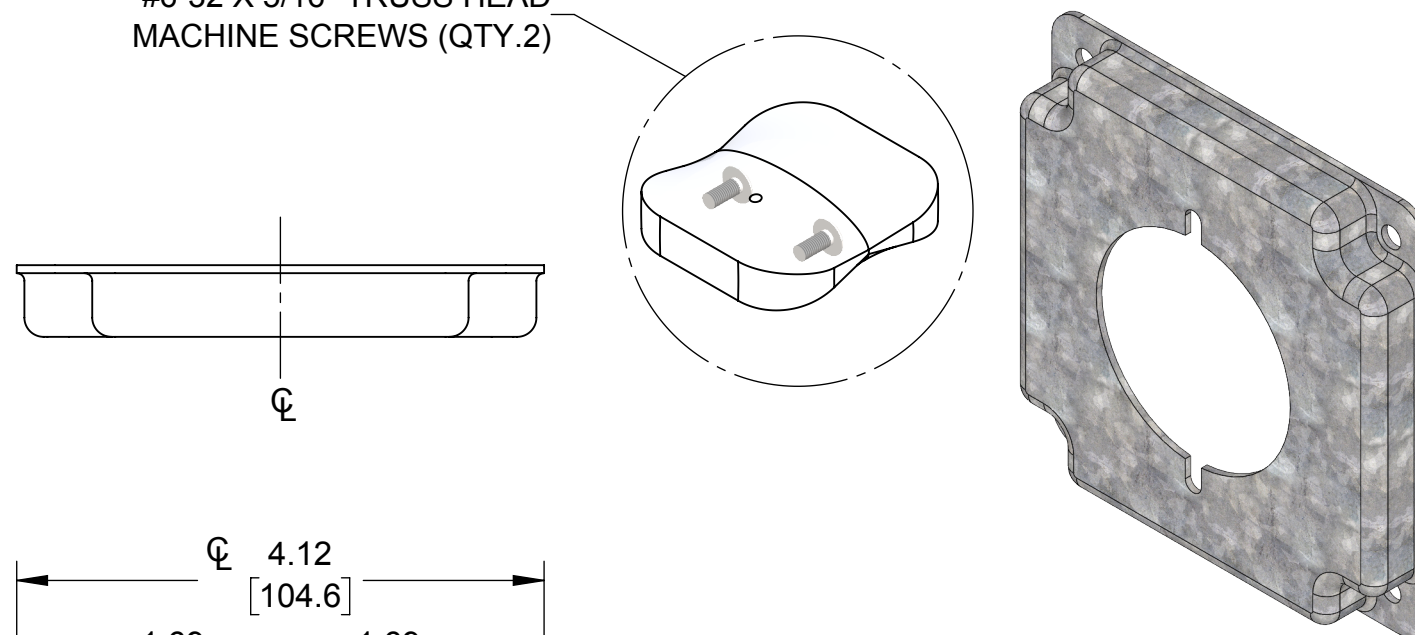

	INITIAL RELEASE	RMV	03-31-17
SYM.	REVISION DESCRIPTION	APP	DATE

THE DESIGN AND DIMENSIONS OF THE  
PRODUCT SHOWN ON THIS DRAWING ARE  
SUBJECT TO CHANGE WITHOUT NOTICE

TITLE:

**4" SQ. CRUSHED CORNER COVER,  
(1) 30-50A RECT 2.141"**

TOLERANCE UNLESS  
OTHERWISE SPECIFIED

.XX DECIMAL ±.015  
.XXX DECIMAL ±.005  
ANGLE ±2°

**RACO**  
South Bend, Indiana

DRAWN BY:	RMV	SCALE:
APP. BY:	RMV	1:1.5
DATE:	03-31-17	

**NOTES:**

- ALL DIMENSIONS ARE IN INCHES AND [MILLIMETERS]
- BOX VOLUME: 6.5 IN<sup>3</sup> [107] CM<sup>3</sup>
- UL LISTED