

- NOTES:
- 1 CREEPAGE DISTANCE: 13.7" / 349mm
  - 2 ARC DISTANCE: 6.8" / 173mm
  - 3 NOMINAL VOLTAGE: 5kV
  - 4 NOMINAL CURRENT: 1600A
  - 5 WITHSTAND VOLTAGE AT 60 sec.: 27kV
  - 6 B.I.L. : 75kV
  - 7 ROUTINE TEST ACCORDING TO: IEEE C57.19.01
  - 8 MAX. TORQUE APPLIED ON FLANGE BOLTS: 40 lbf·ft / 54.2 N·m
  - 9 WEIGHT: 25 lb / 11.6 kg

REVISIONS					
ZONE	REV.	DESCRIPTION	DRAWN BY	DATE	APPR.

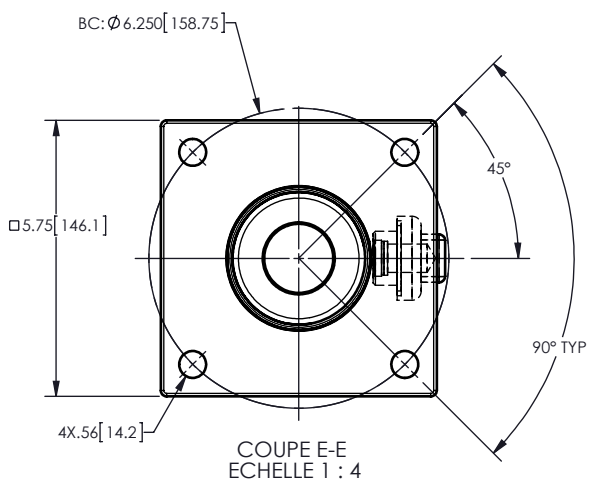
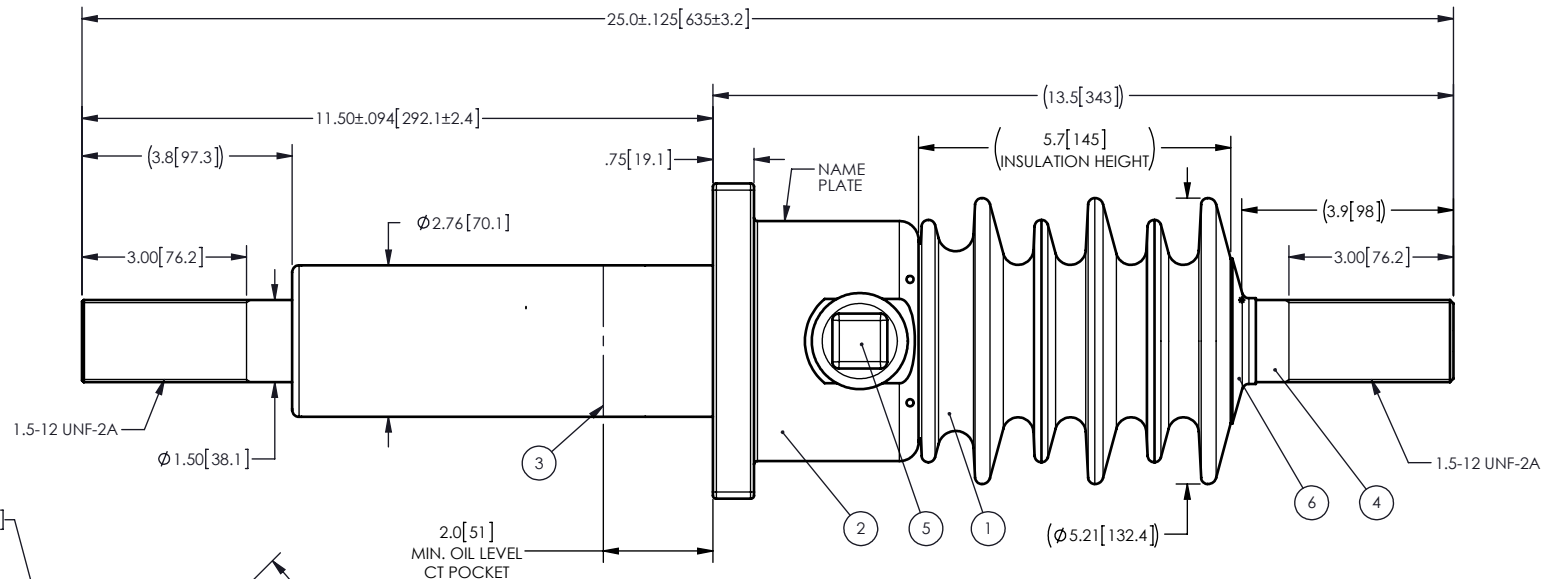

ITEM NO.	QTY	DRAWING NO.	PART NO.	DESCRIPTION	NOTE / MAT'L
6	1	S-1001-0007		CAP	COPPER
5	1	S-1001-2022		CAPACITANCE TAP ASSEMBLY	ALUMINUM
4	1	S-8167-8000		ROD ASSEMBLY	COPPER
3	1	S-8167-7999		SHIELD ASSEMBLY	COPPER
2	1	S-8167-7998		FLANGE	ALUMINUM
1	1	S-8167-7997	-001	CASTING, CYCLOALIPHATIC RESIN	EC-APG-02

PARTS LIST

<p>GENERAL TOLERANCES (UNLESS OTHERWISE SPECIFIED)</p> <p>X. ±0.125</p> <p>.X ±0.094</p> <p>.XX ±0.063</p> <p>.XXX ±0.010</p> <p>ANGLES ±0.25°</p> <p>RADIUS ±0.031</p>	<p>EQUIVALENT TO:</p>	<p><b>Electro Composites</b> solid HV bushings solution</p>			
		<p>TITLE: SDC® BUSHING 5kV, 1600A MODEL: 075-016-T-819-01</p>			
<p>REMOVE BURRS AND BREAK SHARP EDGES</p> <p>DIMENSIONS ARE IN INCHES (UNLESS OTHERWISE SPECIFIED)</p>	<p>DRAWN BY: J.N.PILOTTE</p> <p>CHECK BY:</p> <p>PROJECT ENG.:</p> <p>PROJECT MANAGER:</p>	<p>DATE: 2013-09-03</p>	<p>FORMAT: A</p> <p>SCALE: 1:3.5</p>	<p>CAGE CODE:</p> <p>DRAWING NO.: S-8167-7997</p>	<p>REVISION: NR</p> <p>GENERATED BY: SolidWorks 2012</p> <p>SHEET: 1 of 1</p>

This drawing is the proprietary property of Electro Composites (2008) ULC, not part of the public domain, and is issued with the express understanding and agreement that it is not to be reproduced or copied in whole or in part or issued for furnishing information to others, or used directly or indirectly, in any way detrimental to the interest of Electro Composites (2008) ULC and is to be returned upon request by Electro Composites (2008) ULC. All Rights Reserved.