

NOTES:

- 1 CREEPAGE DISTANCE : 8.6" / 220mm
- 2 ARC DISTANCE : 4.6" / 118mm
- 3 NOMINAL VOLTAGE: 5kV
- 4 NOMINAL CURRENT: 1200A
- 5 WITHSTAND VOLTAGE AT 60 sec.: 27kV
- 6 B.I.L. : 75kV
- 7 APPLICATION STANDARD: IEEE C57.19.01
- 8 MAX. TORQUE APPLIED ON FLANGE BOLTS: 40 lbf x ft
- 9 WEIGHT: 27. lb / 12.4 Kg

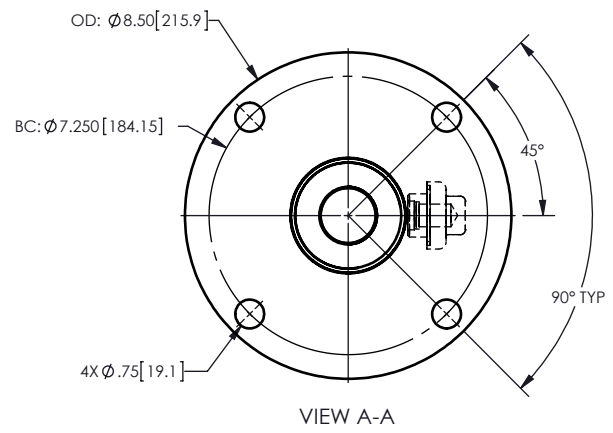
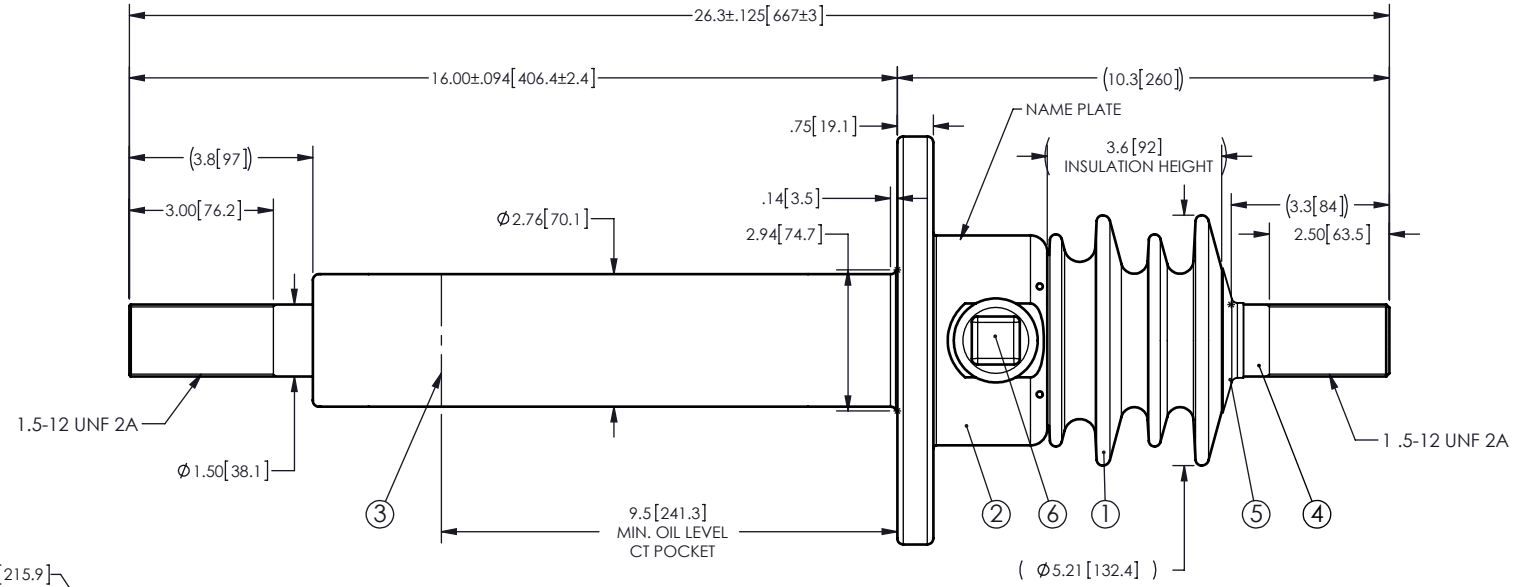

ITEM NO.	QTY	DRAWING NO.	PART NO.	DESCRIPTION	NOTE / MAT'L
6	1	S-1001-2022		CAPACITANCE TAP ASSEMBLY	ALUMINUM
5	1	S-1001-0007		CAP	COPPER
4	1	S-8679-7989		ROD ASSEMBLY	COPPER
3	1	S-8679-7988		SHIELD ASSEMBLY	COPPER
2	1	S-8679-7987		FLANGE	ALUMINUM
1	1	S-8679-7986	-001	CASTING, CYCLOALIPHATIC RESIN	EC-APG-02

PARTS LIST

<p>GENERAL TOLERANCES (UNLESS OTHERWISE SPECIFIED)</p> <p>X. ±0.125 .X ±0.094 .XX ±0.063 .XXX ±0.010 ANGLES ±0.25° RADIUS ±0.031</p>		<p>REPLACE:</p>		<p>ElectroComposites solid HV bushings solution</p>	
<p>REMOVE BURRS AND BREAK SHARP EDGES</p> <p>DIMENSIONS ARE IN INCHES (UNLESS OTHERWISE SPECIFIED)</p>		<p>DRAWN BY: J.N.PILOTTE DATE: 2013/07/09</p>			
<p>TITLE: SDC® BUSHING 5kV, 1200A MODEL: 075-012-T-822-00</p>		<p>FORMAT: A</p>	<p>CAGE CODE:</p>	<p>DRAWING NO.: S-8679-7986</p>	<p>REVISION: NR</p>
<p>SCALE: 1:4</p>		<p>GENERATED BY: SolidWorks 2012</p>		<p>SHEET: 1 of 1</p>	

This drawing is the proprietary property of Electro Composites (2008) ULC, not part of the public domain, and is issued with the express understanding and agreement that it is not to be reproduced or copied in whole or in part or issued for furnishing information to others, or used directly or indirectly, in any way detrimental to the interest of Electro Composites (2008) ULC and is to be returned upon request by Electro Composites (2008) ULC. All Rights Reserved.