

- NOTES:
- 1 CREEPAGE DISTANCE: 25.8" / 656.mm
 - 2 ARC DISTANCE: 11.4" / 289mm
 - 3 NOMINAL VOLTAGE: 25kV
 - 4 NOMINAL CURRENT: 2000A
 - 5 WITHSTAND VOLTAGE AT 60 sec.: 60kV
 - 6 B.I.L. : 150kV
 - 7 ROUTINE TEST ACCORDING TO: IEEE C57.19.01
 - 8 MAX. TORQUE APPLIED ON FLANGE BOLTS: 40 lbf x ft / 54.2 N·m
 - 9 WEIGHT: 64.6 lb / 29.3 Kg
- △10 SILVER PLATED, AS PER ASTM B700, TYPE 1, GRADE D, CLASS N, NO NICKEL LAYER, FROM 13 TO 20 MICROMETERS THICKNESS

| REVISIONS | | | | | |
|-----------|------|-------------|----------|------|-------|
| ZONE | REV. | DESCRIPTION | DRAWN BY | DATE | APPR. |

F
E
D
C
B
A

F
E
D
C
B
A

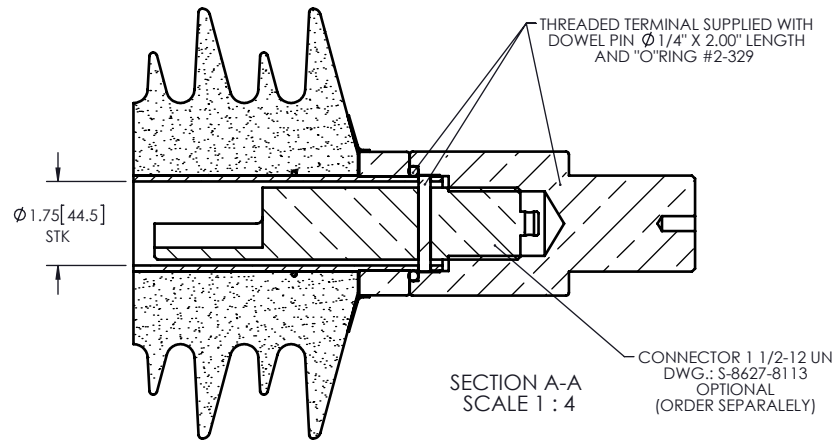
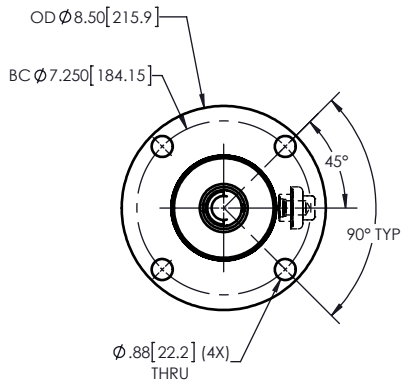
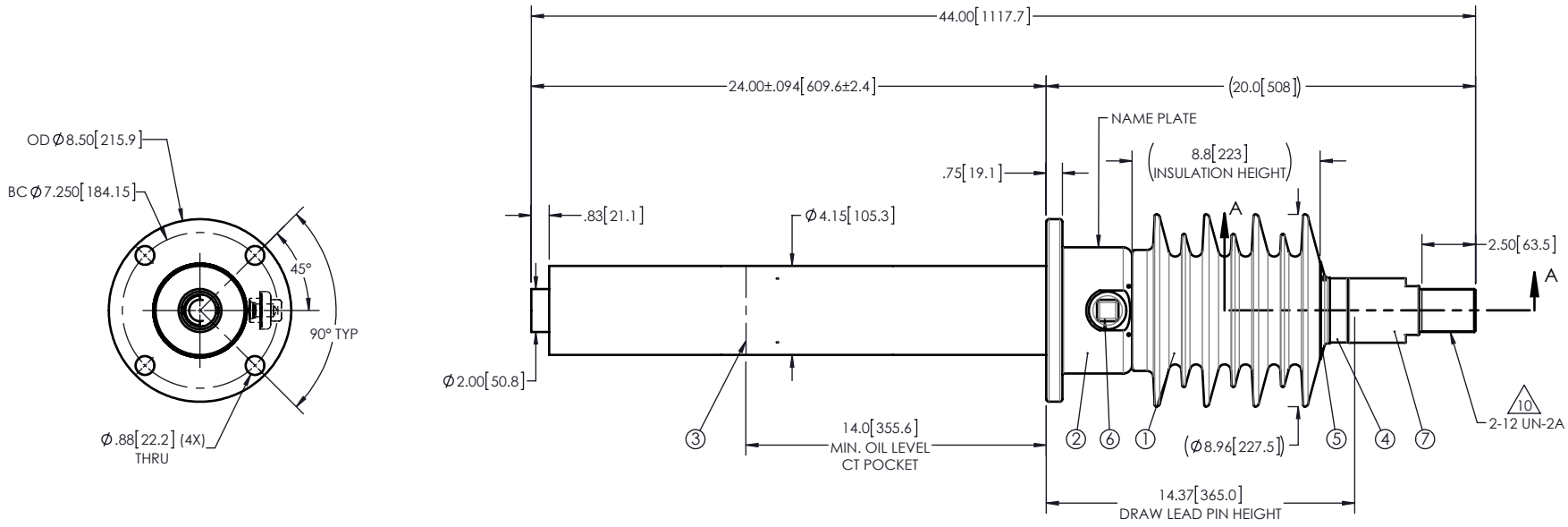

| ITEM NO. | QTY | DRAWING NO. | PART NO. | DESCRIPTION | NOTE / MAT'L |
|----------|-----|---------------|----------|-------------------------------|--------------|
| 7 | 1 | S-8627-8112-1 | | THREADED TERMINAL KIT | COPPER |
| 6 | 1 | S-1001-2022 | | CAPACITANCE TAP ASSEMBLY | ALUMINUM |
| 5 | 1 | S-3529-2532 | | CAP | COPPER |
| 4 | 1 | S-8627-8111 | | TUBE ASSEMBLY | BRASS |
| 3 | 1 | S-8627-8110 | | SHIELD ASSEMBLY | COPPER |
| 2 | 1 | S-6074-5716 | | FLANGE | ALUMINUM |
| 1 | 1 | S-8627-8109 | -001 | CASTING, CYCLOALIPHATIC RESIN | EC-APG-02 |

PARTS LIST

| | | | | |
|---|--|---|--|---|
| GENERAL TOLERANCES (UNLESS OTHERWISE SPECIFIED) X. ±0.125 .X ±0.094 .XX ±0.063 .XXX ±0.010 ANGLES ±0.25° RADIUS ±0.031 | | REPLACE: DRAWN BY: J.N.PILOTTE DATE: 2013/10/28 | Electro Composites solid HV bushings solution | |
| REMOVE BURRS AND BREAK SHARP EDGES DIMENSIONS ARE IN INCHES (UNLESS OTHERWISE SPECIFIED) | | PROJECT ENG.: PROJECT MANAGER: | TITLE: SDC® BUSHING , 25kV, 2000A MODEL: 150-020-T-834-00 | |
| | | CHECK BY: PROJECT MANAGER: | FORMAT: A SCALE: 1:8 | CAGE CODE: DRAWING NO.: S-8627-8109 REVISION: NR SHEET: 1 of 1 |

This drawing is the proprietary property of Electro Composites (2008) ULC, not part of the public domain, and is issued with the express understanding and agreement that it is not to be reproduced or copied in whole or in part or issued for furnishing information to others, or used directly or indirectly, in any way detrimental to the interest of Electro Composites (2008) ULC and is to be returned upon request by Electro Composites (2008) ULC. All Rights Reserved.

6 5 4 3 2 1