

NOTES: 1 CREEPAGE DISTANCE: 32.6" / 828mm  
 2 ARC DISTANCE: 13.0" / 330mm  
 3 NOMINAL VOLTAGE: 25kV  
 4 NOMINAL CURRENT: 10,000A  
 5 VOLTAGE WITHSTAND, 60 sec.: 60kV  
 6 BIL: 150kV  
 7 ROUTINE TEST ACCORDING TO: IEEE C57.19.01  
 8 MAX. TORQUE APPLIED ON FLANGE BOLTS: 70 lbf·ft / 94.9 N·m  
 9 WEIGHT: 302 lb / 137.0 Kg  
 10 MAXIMUM OPERATING TEMPERATURE: 130°C (266°F)

⚠ THE TEST TAP CAN BE ORIENTED IN 6 POSITIONS IN RELATION WITH THE BOTTOM SPADE: +15°±1° (AS SHOWN AT ZONE B5), +45°±1°, +75°±1°, +105°±1°, +135°±1° AND +165°±1°

⚠ SILVER PLATED, AS PER ASTM B700, TYPE 1, GRADE D, CLASS N, NO NICKEL LAYER, FROM 13 TO 20 MICROMETERS THICKNESS

ZONE		REV.	DESCRIPTION	DRAWN BY	DATE	APPR.
A4		A	ADD THE DIMENSION OF THE FLANGE HOLE	J. CLICHE	2014-07-10	Y.V.

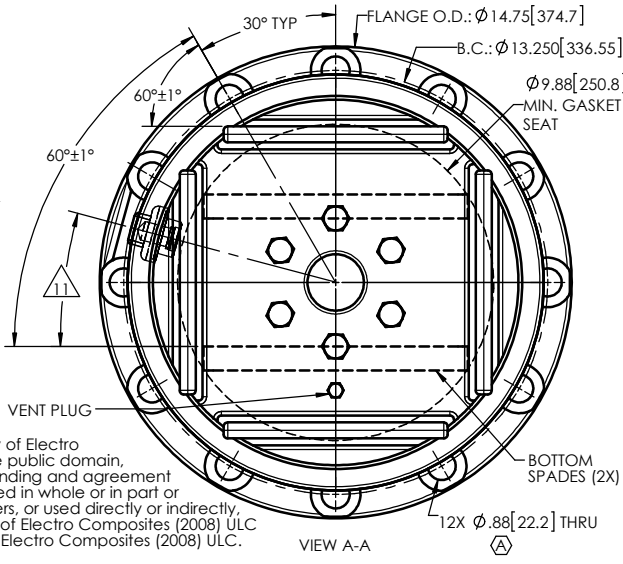
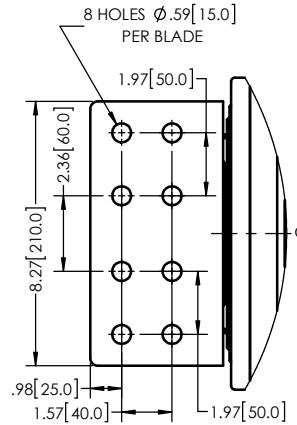
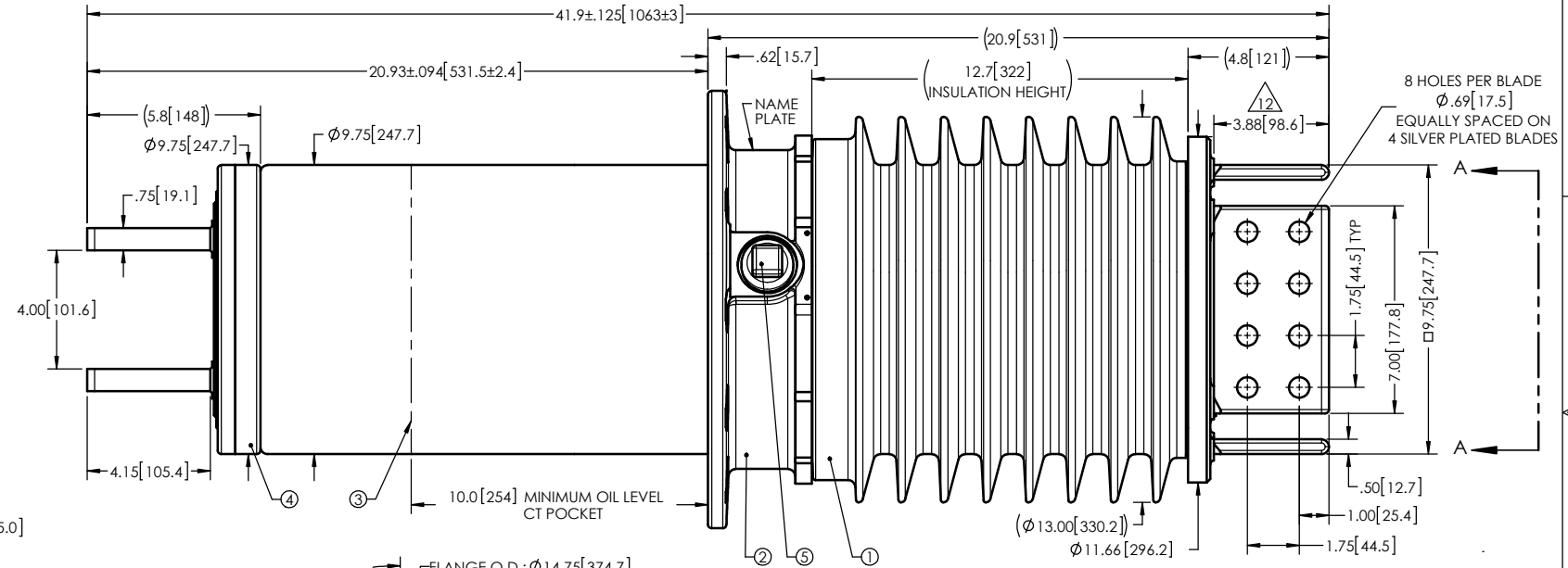

ITEM NO.	QTY	DRAWING NO.	PART NO.	DESCRIPTION	NOTE / MAT'L
5	1	S-1001-2022		CAPACITANCE TAP ASSEMBLY	ALUMINUM
4	1	S-3969-8383		TUBE ASSEMBLY	COPPER
3	1	S-3969-8382		SHIELD ASSEMBLY	BRASS
2	1	S-3969-8381		FLANGE	ALUMINUM
1	1	S-3969-8380	-001	CASTING, CYCLOALIPHATIC RESIN	EC-APG-15NA

**Electro Composites**  
 solid HV bushings solution

TITLE: SDC® GSU BUSHING 25kV, 10,000A  
 MODEL: 150-100-G-874-00

GENERAL TOLERANCES (UNLESS OTHERWISE SPECIFIED)  
 X. ±0.125  
 .X ±0.094  
 .XX ±0.063  
 .XXX ±0.031  
 ANGLES ±0.25°  
 RADIUS ±0.031

REMOVE BURRS AND BREAK SHARP EDGES

DIMENSIONS ARE IN INCHES (UNLESS OTHERWISE SPECIFIED)

DRAWN BY: J. CLICHE DATE: 2014/05/02  
 CHECK BY: PROJECT ENG.: PROJECT MANAGER:

FORMAT: A CAGE CODE: DRAWING NO.: S-3969-8380 REVISION: A  
 SCALE: 1:6 GENERATED BY: SolidWorks 2013 SHEET: 1 OF 1

This drawing is the proprietary property of Electro Composites (2008) ULC, not part of the public domain, and is issued with the express understanding and agreement that it is not to be reproduced or copied in whole or in part or issued for furnishing information to others, or used directly or indirectly, in any way detrimental to the interest of Electro Composites (2008) ULC and is to be returned upon request by Electro Composites (2008) ULC. All Rights Reserved.