

DESCRIPTION	MATERIAL	FINISH
COVER	STEEL	GALVANIZED
SCREWS	STEEL	GALVANIZED
NUTS	STEEL	GALVANIZED

#8-32 X 1-1/8" THREAD CUTTING MACHINE SCREWS (QTY. 2)
 #6-32 X 7/16" MACHINE SCREWS (QTY. 4)

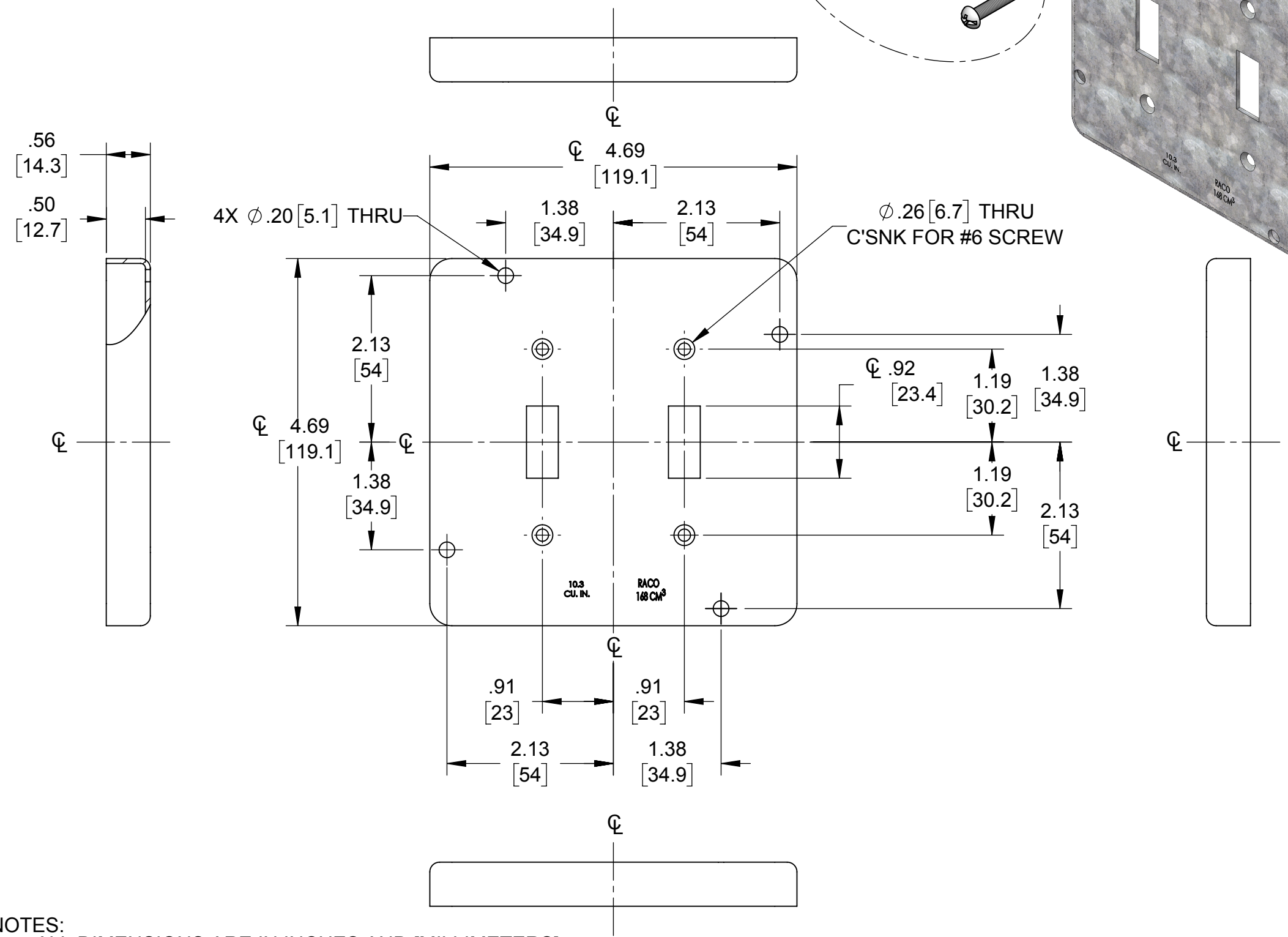
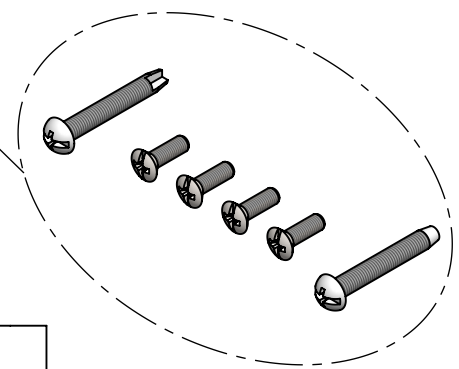

- NOTES:
- ALL DIMENSIONS ARE IN INCHES AND [MILLIMETERS]
 - BOX VOLUME: 10.3 IN³ [168] CM³
 - UL LISTED

SYM.	REVISION DESCRIPTION	RMV APP	DATE

THE DESIGN AND DIMENSIONS OF THE PRODUCT SHOWN ON THIS DRAWING ARE SUBJECT TO CHANGE WITHOUT NOTICE

TITLE: **4-11/16" SQ. COVER, RAISED 1/2", (2) TOGGLE SWITCHES**

TOLERANCE UNLESS OTHERWISE SPECIFIED		RACO South Bend, Indiana		
.XX DECIMAL ±.015	DRAWN BY: RMV			SCALE: 1:1.5
.XXX DECIMAL ±.005	APP. BY: RMV			
ANGLE ±2°	DATE: 07-12-17			