

- NOTES:
- 1 CREEPAGE DISTANCE: 38.9" / 989mm
 - 2 ARC DISTANCE: 19.0" / 482mm
 - 3 NOMINAL VOLTAGE: 69kV
 - 4 NOMINAL CURRENT: 1200A
 - 5 VOLTAGE WITHSTAND, 60 sec.: 160kV
 - 6 BIL : 350kV
 - 7 ROUTINE TEST ACCORDING TO: IEEE C57.19.01
 - 8 MAX. TORQUE APPLIED ON FLANGE BOLTS: 40 lbf · ft / 54.2 N · m
 - 9 WEIGHT: 90 lb / 40.8 kg
 - 10 BUSHING TO BE FULLY IMMERSSED UNDER OIL ON BOTH SIDES OF FLANGE.

REVISIONS					
ZONE	REV.	DESCRIPTION	DRAWN BY	DATE	APPR.
	A	THE CAP HAS BEEN REMOVED, IT'S NOT NECESSARY FOR THIS APPLICATION + INSULATION HEIGHT WAS 403mm	A.SAVARD	2015-03-18	J.V.
A1	B	PART # HAS BEEN CHANGED ACCORDING TO THE OIL-OIL APPLICATION: 350-020-I-903-00 BECOMES 350-020-O-903-00	A.SAVARD	2020-05-15	J.V.
B4 C2, F5	C	SHIELD ASSEMBLY S-5158-4682 CHANGED TO S-1288-1396 ADD SHEDS AND INCREASE CREEP DISTANCE ACCORDINGLY	M. FORGET	2022-03-10	J.V.

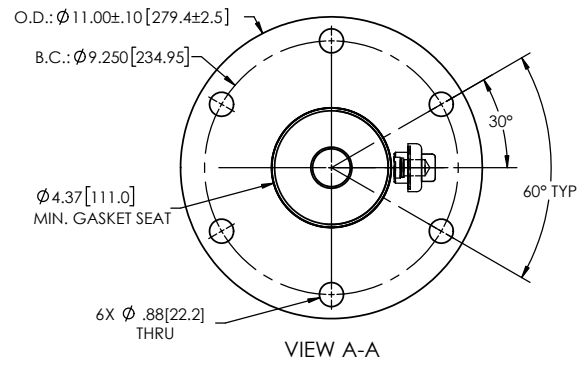
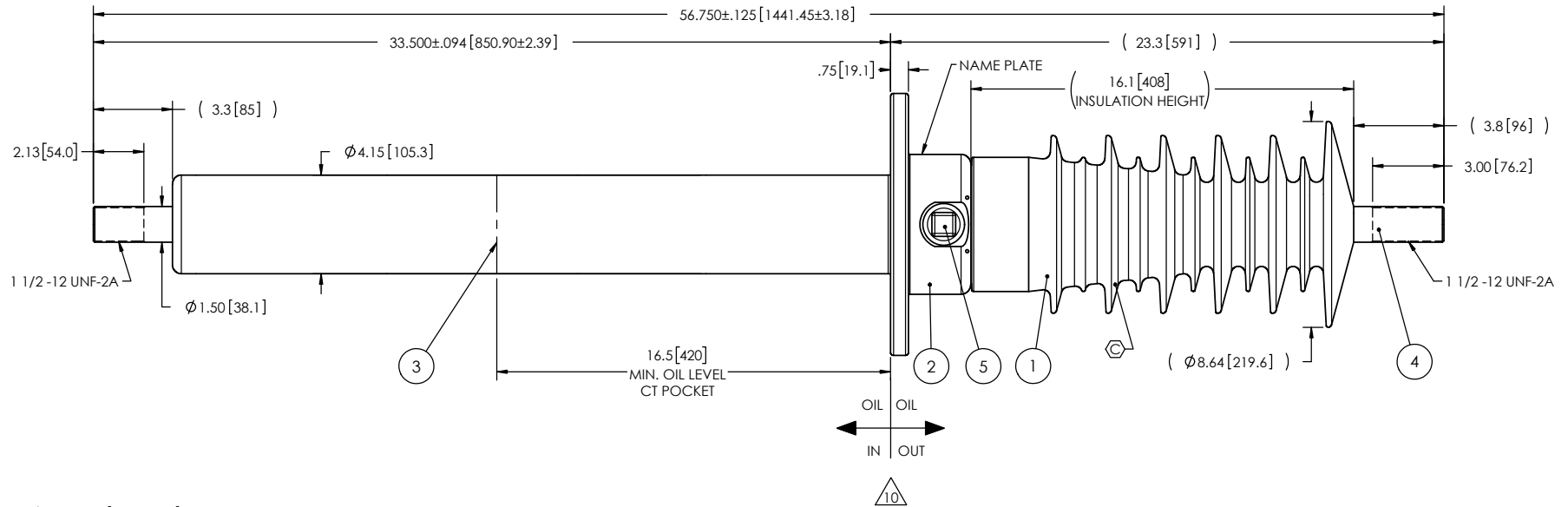

ITEM NO.	QTY	DRAWING NO.	PART NO.	DESCRIPTION	NOTE / MAT'L
5	1	S-1001-2022		CAPACITANCE TAP ASSEMBLY	ALUMINUM
4	1	S-1288-8727		ROD ASSEMBLY	COPPER
3	1	S-1288-10396		SHIELD ASSEMBLY	COPPER
2	1	S-7578-7089		FLANGE	ALUMINUM
1	1	S-1288-8726	-001	CASTING, CYCLOALIPHATIC RESIN	EC-APG-02

PARTS LIST						
GENERAL TOLERANCES (UNLESS OTHERWISE SPECIFIED)				ElectroComposites™ solid HV bushings solution TITLE: SDC® BUSHING , 69kV, 1200A MODEL: 350-012-O-903-00		
X.	±0.125	DRAWN BY: J. CLICHE				DATE: 2015/02/20
.X	±0.094	CHECK BY:				
.XX	±0.063	PROJECT ENG.:				
.XXX	±0.031	PROJECT MGR.:			SCALE: 1:7	
ANGLES	±0.25°			GENERATED BY: SolidWorks 2021	SHEET: 1 of 1	
RADIUS	±0.031					
REMOVE BURRS AND BREAK SHARP EDGES						
DIMENSIONS ARE IN INCHES (UNLESS OTHERWISE SPECIFIED)						

This drawing is the proprietary property of Electro Composites (2008) ULC, not part of the public domain, and is issued with the express understanding and agreement that it is not to be reproduced or copied in whole or in part or issued for furnishing information to others, or used directly or indirectly, in any way detrimental to the interest of Electro Composites (2008) ULC and is to be returned upon request by Electro Composites (2008) ULC. All Rights Reserved.