

LIST OF PARTS

DESCRIPTION	MATERIAL	FINISH
COVER	STEEL	GALVANIZED
SCREWS	STEEL	GALVANIZED
NUTS	STEEL	GALVANIZED

#6-32 X 1 1/32" BINDING HEAD
MACHINE SCREWS (QTY. 4)

#6-32 NUTS (QTY. 4)

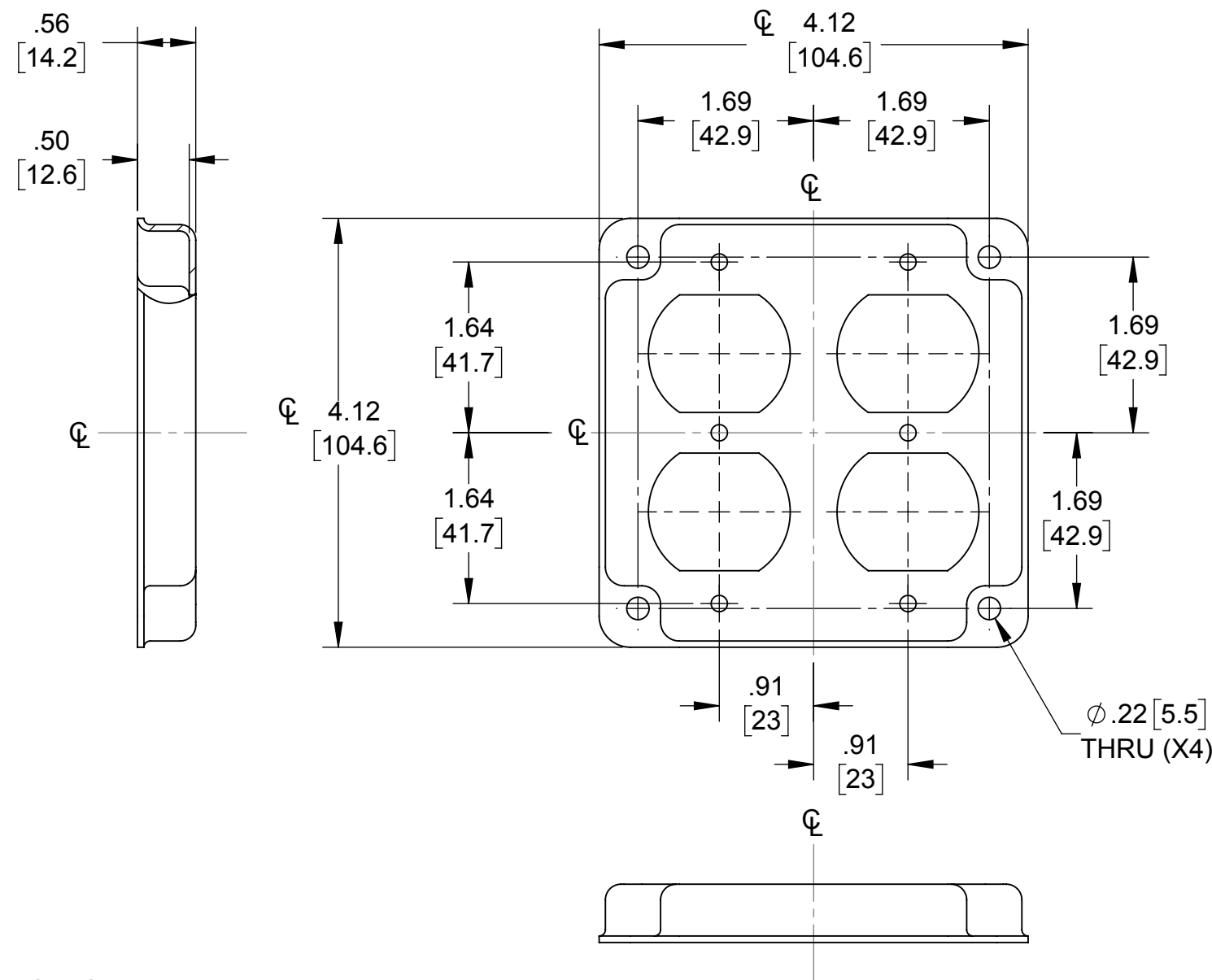
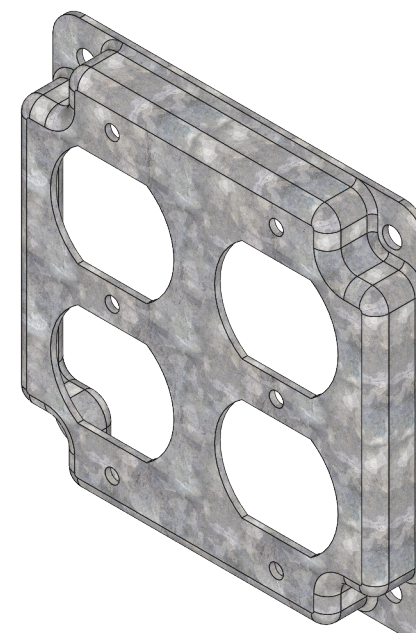
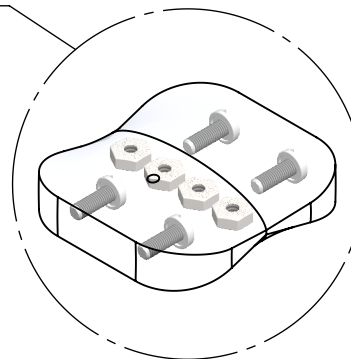

- NOTES:
1. ALL DIMENSIONS ARE IN INCHES AND [MILLIMETERS]
 2. BOX VOLUME: 6.5 IN³ [107] CM³
 3. UL LISTED

SYM.	REVISION DESCRIPTION	APP	DATE
	INITIAL RELEASE	RMV	04-03-17

THE DESIGN AND DIMENSIONS OF THE
PRODUCT SHOWN ON THIS DRAWING ARE
SUBJECT TO CHANGE WITHOUT NOTICE

TITLE:

**4" SQ. CRUSHED CORNER COVER,
(2) DUPLEX**

TOLERANCE UNLESS
OTHERWISE SPECIFIED

.XX DECIMAL ±.015
.XXX DECIMAL ±.005
ANGLE ±2°

RACO
South Bend, Indiana

DRAWN BY:	RMV	SCALE:	1:1.5
APP. BY:	RMV		
DATE:	04-03-17		