

NOTES:

- 1 CREEPAGE DISTANCE: 145.1" / 3687mm
- 2 ARC DISTANCE: 46.7" / 1184mm
- 3 NOMINAL VOLTAGE: 115kV
- 4 NOMINAL CURRENT: 800A
- 5 WITHSTAND VOLTAGE AT 60 sec.: 260kV
- 6 B.I.L. : 550kV
- 7 ROUTINE TEST ACCORDING TO: IEEE C57.19.01
- 8 MAX. TORQUE APPLIED ON FLANGE BOLTS: 70 lbf x ft [94.9 N.m]
- 9 WEIGHT: 245 lbs / 111.2 Kg
- 10 SILVER PLATED TOP END, AS PER ASTM B700,TYPE 1, GRADE D, CLASS N, NO NICKEL LAYER, FROM 13 TO 20 MICROMETERS THICKNESS
- 11 FOR DRAW LEAD APPLICATION ONLY

REVISIONS					
ZONE	REV.	DESCRIPTION	DRAWN BY	DATE	APPR.

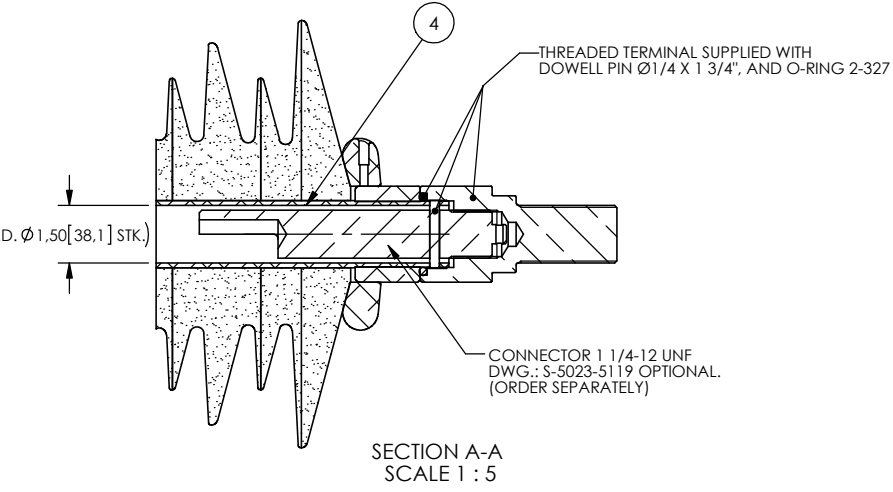
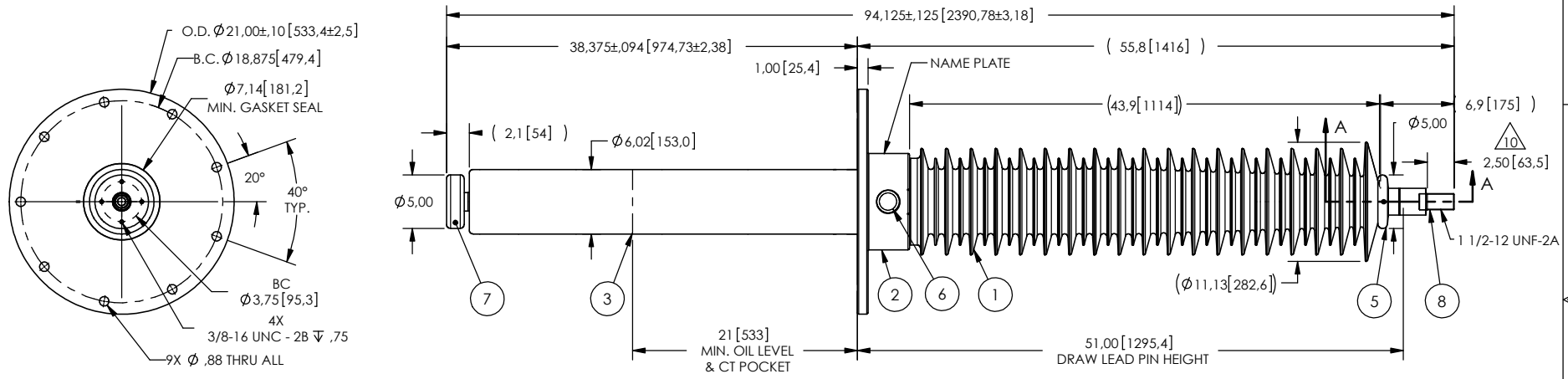

ITEM NO.	QTY	DRAWING NO.	PART NO.	DESCRIPTION	NOTE / MAT'L
8	1	S-6397-5967-1		THREADED TERMINAL KIT	COPPER
7	1	S-5023-5118		CORONA RING BOTTOM	ALUMINUM
6	1	S-2878-2606		CAPACITANCE TAP ASSEMBLY	ALUMINUM
5	1	S-5085-5779		CORONA RING STYLE CAP	ALUMINUM
4	1	S-8910-8792		TUBE ASSEMBLY	ALUMINUM
3	1	S-8910-8791		SHIELD ASSEMBLY	BRASS
2	1	S-8910-8790		FLANGE	ALUMINUM
1	1	S-8910-8789	-001	CASTING, CYCLOALIPHATIC RESIN	EC-APG-02

PARTS LIST					
GENERAL TOLERANCES (UNLESS OTHERWISE SPECIFIED)		REPLACE:		Electro Composites solid HV bushings solution TITLE: SDC® BUSHING 115kV, 800A MODEL: 550-008-T-913-00	
X.	±0.125	DRAWN BY: A.SAVARD			
.X	±0.094	DATE: 2015/04/28			
.XX	±0.063	CHECK BY:			
.XXX	±0.031	PROJECT NO.:			
ANGLES	±0.25°	PROJECT MANAGER:			
RADIUS	±0.031	SCALE: 1:15			
REMOVE BURRS AND BREAK SHARP EDGES		FORMAT: A		CAGE CODE: S-8910-8789	
DIMENSIONS ARE IN INCHES (UNLESS OTHERWISE SPECIFIED)		DRAWING NO.:		REVISION: NR	
		GENERATED BY: SolidWorks 2013		SHEET: 1 of 1	

This drawing is the proprietary property of Electro Composites (2008) ULC, not part of the public domain, and is issued with the express understanding and agreement that it is not to be reproduced or copied in whole or in part or issued for furnishing information to others, or used directly or indirectly, in any way detrimental to the interest of Electro Composites (2008) ULC and is to be returned upon request by Electro Composites (2008) ULC. All Rights Reserved.