

NOTES:

- 1 CREEPAGE DISTANCE: 21.1" / 536mm
- 2 ARC DISTANCE: 10.8" / 274mm
- 3 NOMINAL VOLTAGE: 15kV
- 4 NOMINAL CURRENT: 1200A
- 5 VOLTAGE WITHSTAND, 60 sec.: 50kV
- 6 BIL: 110kV
- 7 ROUTINE TEST ACCORDING TO: CSA C88.1-96
- 8 MAX. TORQUE APPLIED ON FLANGE BOLTS: 40 lbf·ft / 54.2 N·m
- 9 WEIGHT: 42 lb / 17.7 Kg

REVISIONS					
ZONE	REV.	DESCRIPTION	DRAWN BY	DATE	APPR.

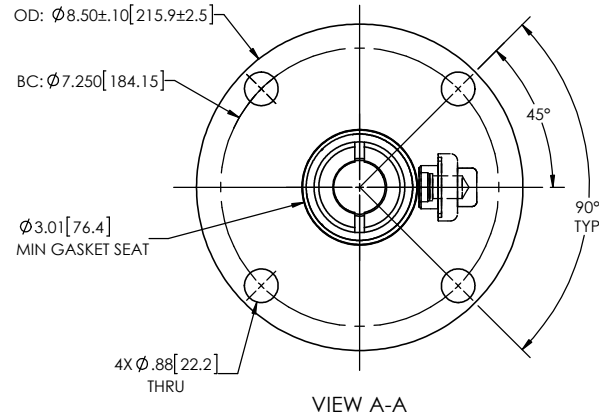
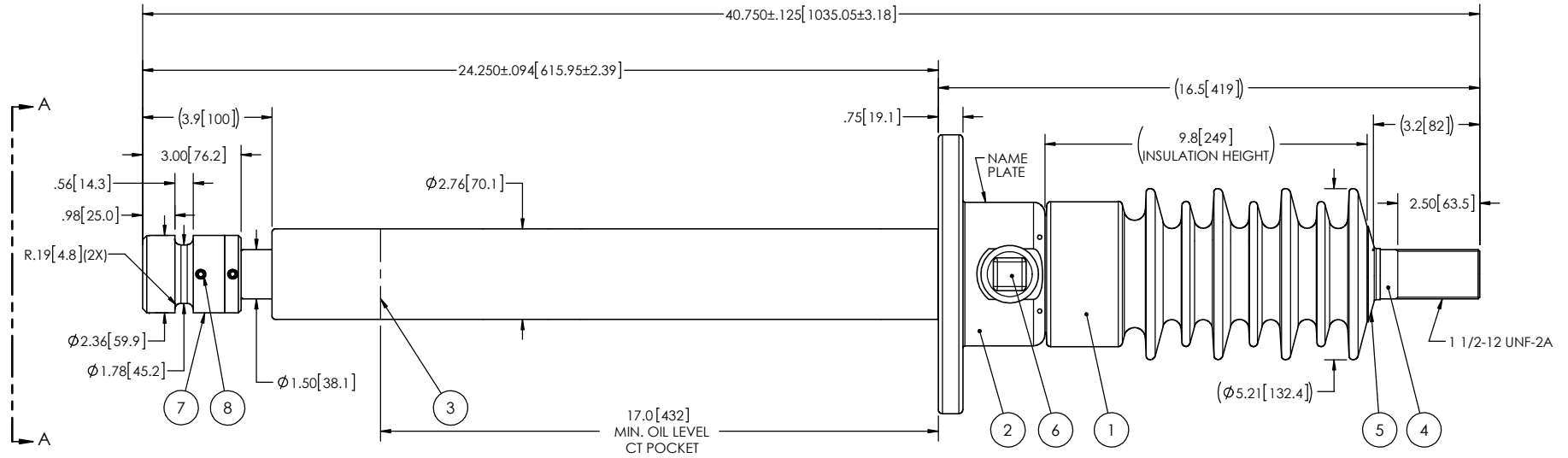

This drawing is the proprietary property of Electro Composites (2008) ULC, not part of the public domain, and is issued with the express understanding and agreement that it is not to be reproduced or copied in whole or in part or issued for furnishing information to others, or used directly or indirectly, in any way detrimental to the interest of Electro Composites (2008) ULC and is to be returned upon request by Electro Composites (2008) ULC. All Rights Reserved.

ITEM NO.	QTY	DRAWING NO.	PART NO.	DESCRIPTION	NOTE / MATL
8	2		S-1001-2465-229	CP SET SCREW, 5/16 -18 X 3/8"	S-STEEL
7	1	S-6640-10068		CONNECTOR	COPPER
6	1	S-1001-2022		CAPACITANCE TAP ASSEMBLY	ALUMINUM
5	1	S-1001-0007		CAP	COPPER
4	1	S-9729-9507		ROD ASSEMBLY	COPPER
3	1	S-6753-6450		SHIELD ASSEMBLY	COPPER
2	1	S-7314-6911		FLANGE	ALUMINUM
1	1	S-6640-10067	-001	CASTING, CYCLOALIPHATIC RESIN	EC-APG-02

PARTS LIST					
GENERAL TOLERANCES (UNLESS OTHERWISE SPECIFIED)			<p><b>Electro Composites</b> solid HV bushings solution</p> <p>TITLE: SDC® BUSHING 15KV, 1200A MODEL: 110-012-B-926-05</p>		
X.	±0.125				
.X	±0.094				
.XX	±0.063				
.XXX	±0.031				
ANGLES	±0.25°				
RADIUS	±0.031				
REMOVE BURRS AND BREAK SHARP EDGES			DRAWN BY: M. FORGET DATE: 2019/11/21		
DIMENSIONS ARE IN INCHES (UNLESS OTHERWISE SPECIFIED)			CHECK BY:		
			PROJECTING:		
			PROJECT MANAGER:		
SCALE: 1:10		DRAWING NO.: S-6640-10067		REVISION: NR	
GENERATED BY: SolidWorks 2013		SHEET: 1 of 1			