

REVISIONS				
REV.	ECN	DATE	DESCRIPTION	BY
-	R21-8	12-08-21	INITIAL RELEASE OF DRAWING	RMV
-	R21-8	03-03-22	PALLET WAS 5 LAYERS OF CARTONS	RMV

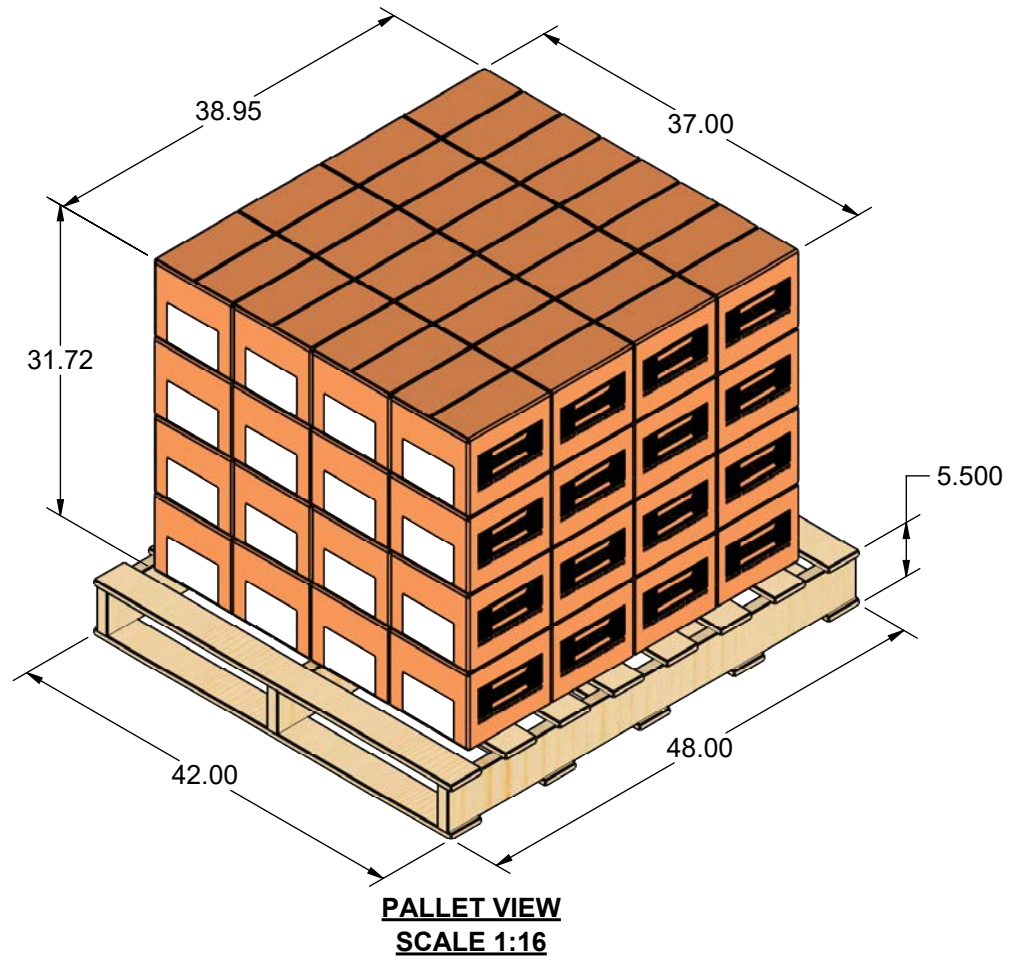
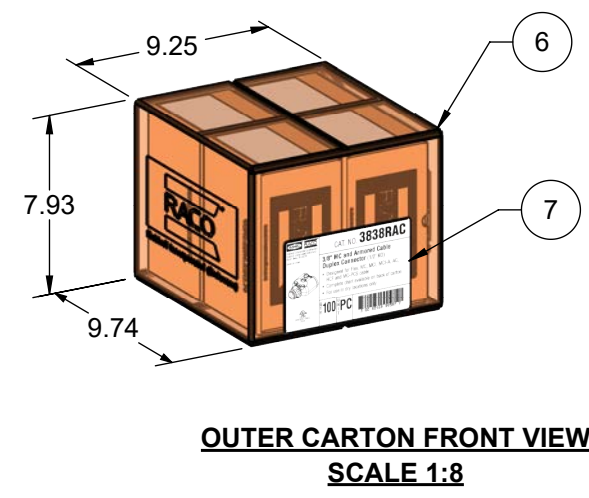
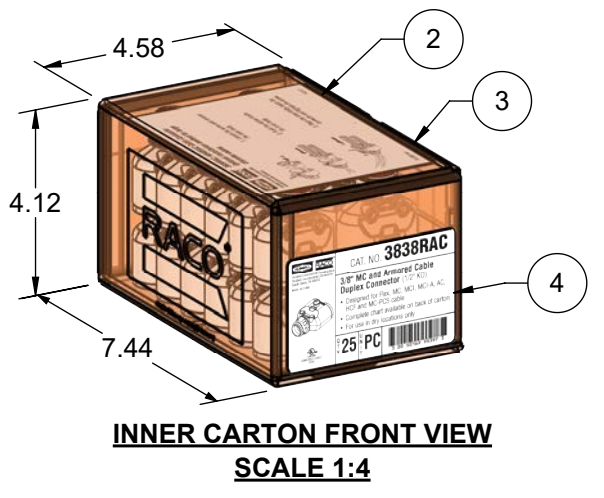
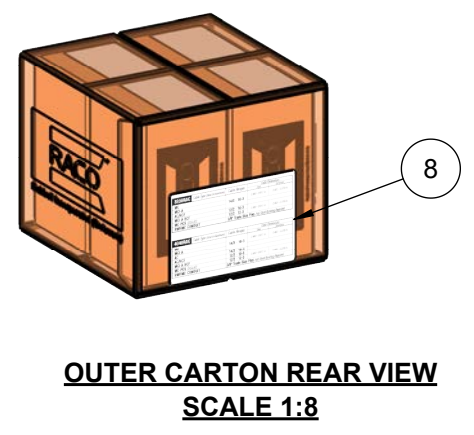
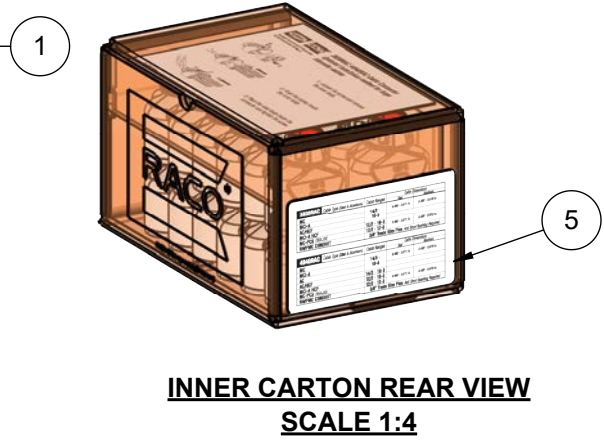
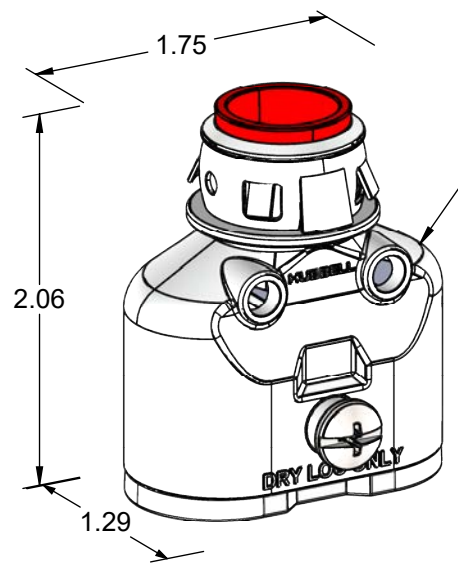

**PACKING INSTRUCTIONS:**

- 25 FULLY ASSEMBLED PARTS (ITEM 1) ARE TO BE PLACED INTO INNER CARTON (ITEM 3). (AS PER DRAWING)
- INSTRUCTION SHEET (ITEM 2) IS TO BE PLACED INTO INNER CARTON (ITEM 3). (AS PER DRAWING)
- CARTON INNER FRONT LABEL (ITEM 4) IS TO BE CENTERED AND PLACED ON END OF CARTON. (AS PER DRAWING)
- CARTON INNER REAR LABEL (ITEM 5) IS TO BE CENTERED AND PLACED ON END OF CARTON. (AS PER DRAWING)
- CARTON IS TO BE CLOSED AND THEN SEALED WITH 2" CLEAR TAPE. (AS PER DRAWING)
- 4 PACKED INNER CARTONS ARE TO BE PLACED IN OUTER CARTON (ITEM 6). (AS PER DRAWING)
- CARTON OUTER FRONT LABEL (ITEM 7) IS TO BE CENTERED AND PLACED ON LABEL TARGETS. (AS PER DRAWING)
- CARTON OUTER REAR LABEL (ITEM 8) IS TO BE CENTERED AND PLACED ON LABEL TARGETS. (AS PER DRAWING)
- CARTON MINOR THEN MAJOR FLAPS ARE TO BE CLOSED AND THEN SEALED WITH 2" CLEAR TAPE. (AS PER DRAWING)
- DATE CODE IS TO BE PLACED ON CARTON AS PER DRAWING C-4-15962.
- 16 CARTONS ARE TO BE ALIGNED ON PALLET PER LAYER. (AS PER DRAWING)
- 4 LAYERS ARE TO BE STACKED PER PALLET. (AS PER DRAWING)

**NOTE:** FOR ADDITIONAL INFORMATION SCROLL DOWN TO NEXT SHEET  
FINAL ASSEMBLY ON SHEET #2

ITEM	PART NO.	DESCRIPTION	QTY.	DWG. NO.
8	403555	LABEL, 4 X 6, CAT 3838RAC/4040RAC, CHINA	1	C-1-19002
7	403554	LABEL, 4 X 6, CAT 3838RAC, CHINA	1	C-1-19001
6	VSR9.49X9.00X7.56	CARTON, VENDOR SUPPLIED	1	VSR9.49X9.00X7.56
5	403553	LABEL, 2.5 X 4, CAT 3838RAC/4040RAC, CHINA	4	C-1-19000
4	403552	LABEL, 2.5 X 4, CAT 3838RAC, CHINA	4	C-1-18999
3	VSR6.69X4.33X3.74	VENDOR SUPPLIED DIE CUT CARTON	4	VSR6.69X4.33X3.74
2	119117	3838RAC/4040RAC CONNECTOR REMOVAL INSTRUCTION SHEET	4	C-1-19291
1	3838RAC	3/8" DOUBLE BARREL CONNECTOR	100	C-4-18516

MATERIAL:		N/A		TITLE:		<b>CAT 3838RAC CHINA PACKING DETAILS</b>	
FINISH:		N/A		BY:		RMV	
		DATE:		DATE:		03-30-21	
		UNLESS OTHERWISE SPECIFIED DIMENSIONS ARE IN INCHES		PART NO.:		3838RAC	
		TOLERANCES:		SIZE:		DRAWING NO.:	
		.XX DECIMAL ±.015		SCALE:		1:1	
		.XXX DECIMAL ±.005		REV.:		-	
		ANGLE ±1		SHEET:		1 OF 2	

SHEET 1 OF 2

C-4-18516

REVISIONS

REV.	ECN	DATE	DESCRIPTION	BY
-	R21-8	12-08-21	INITIAL RELEASE OF DRAWING	RMV
-	R21-8	03-03-22	PALLET WAS 5 LAYERS OF CARTONS	RMV

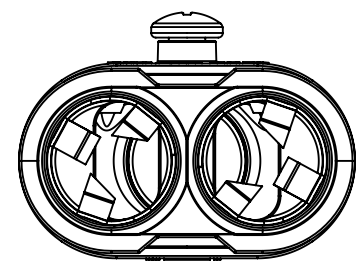
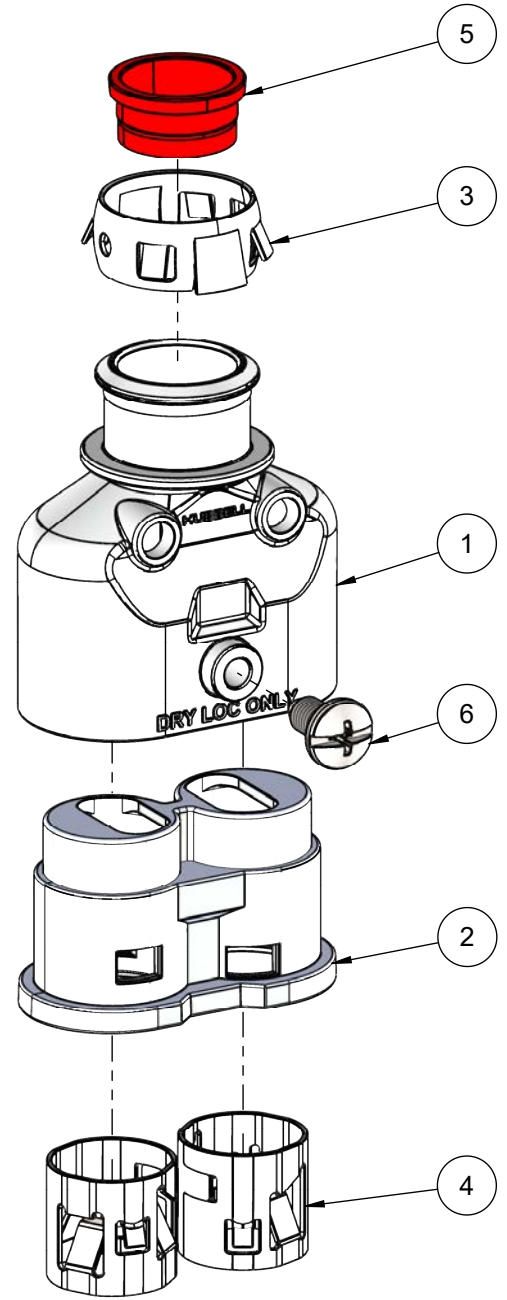
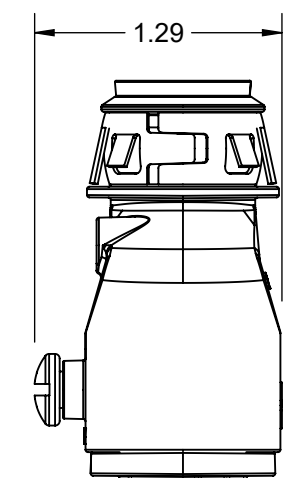
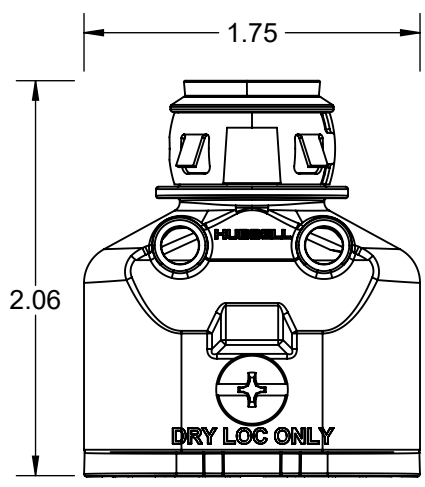
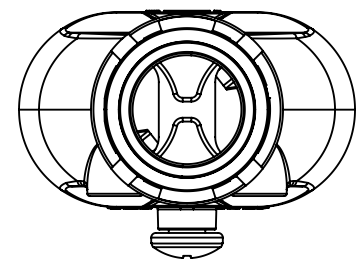
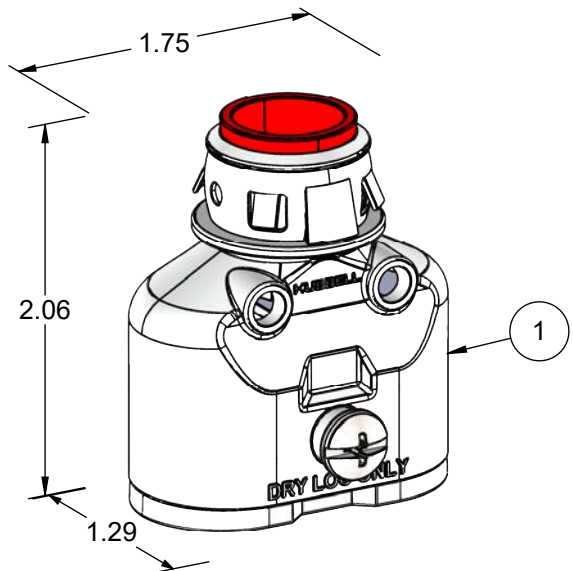

ITEM	PART NO.	DESCRIPTION	QTY.	DWG. NO.
6	202626	SCREW, #10-32 X 3/8" L PH COMBO	1	C-1-19199
5	202625	INSULINER	1	C-1-19198
4	202623	INNER SPRING 3838RAC	2	C-1-19196
3	202622	OUTER SPRING	1	C-1-19195
2	202621	SPRING RETAINER	1	C-1-19194
1	202620	MAIN BODY	1	C-1-19193

**NOTE:**  
PACKING DETAILS ON SHEET #1

MATERIAL:		N/A				TITLE:		CAT 3838RAC FINAL ASSEMBLY	
FINISH:		N/A				BY:	DATE:	PART NO.:	
THIS DRAWING IS THE PROPERTY OF RACO, AND CONTAINS PROPRIETARY AND CONFIDENTIAL INFORMATION WHICH MUST NOT BE REPRODUCED, USED, OR DISCLOSED OTHER THAN AS EXPRESSLY AUTHORIZED BY RACO.				UNLESS OTHERWISE SPECIFIED DIMENSIONS ARE IN INCHES TOLERANCES: .XX DECIMAL ±.015 .XXX DECIMAL ±.005 ANGLE ±1		SIZE: DRAWING NO.: <b>B C-4-18516</b>		REV: - SCALE: 1:1 SHEET 2 OF 2	