

S.NO	CATALOG NUMBER	L	B
1	NSSM250-2SL	4.28 [109]	2
2	NSSM250-2SLI	4.28 [109]	2
3	NSSM250-3SL	5.15 [131]	3
4	NSSM250-3SLI	5.15 [131]	3
5	NSSM250-4SL	6.03 [153]	4
6	NSSM250-4SLI	6.03 [153]	4
7	NSSM250-6SL	7.78 [198]	6
8	NSSM250-6SLI	7.78 [198]	6
9	NSSM250-8SL	9.53 [242]	8
10	NSSM250-8SLI	9.53 [242]	8

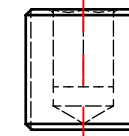

SCREWS ARE SUPPLIED WITH CONNECTOR AND COMES FULLY ASSEMBLED.

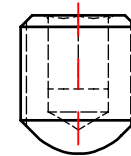
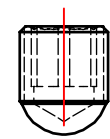
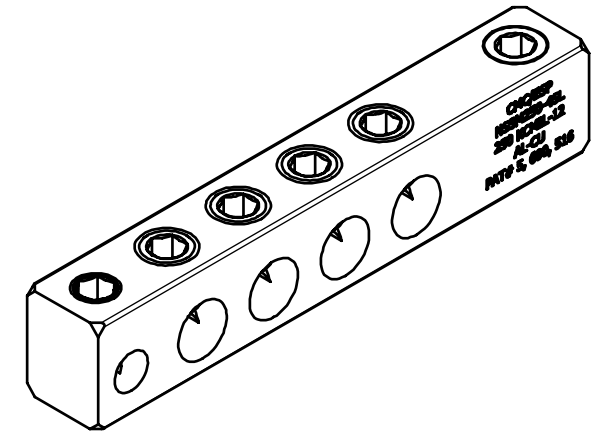
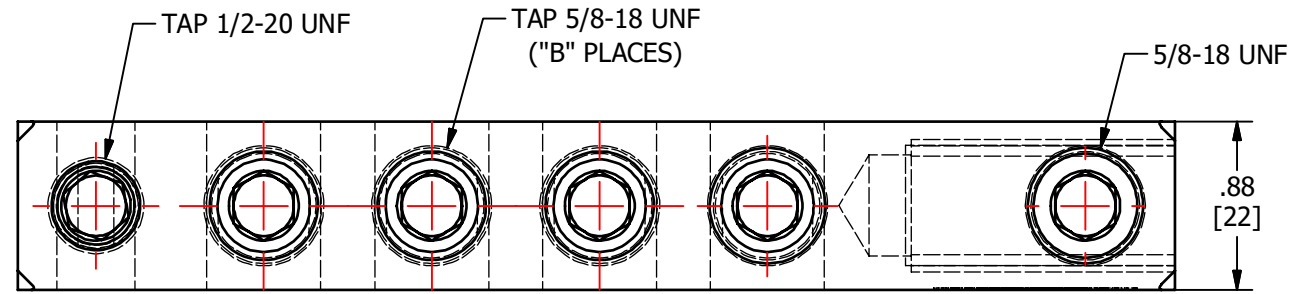
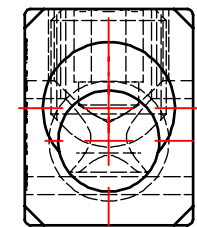
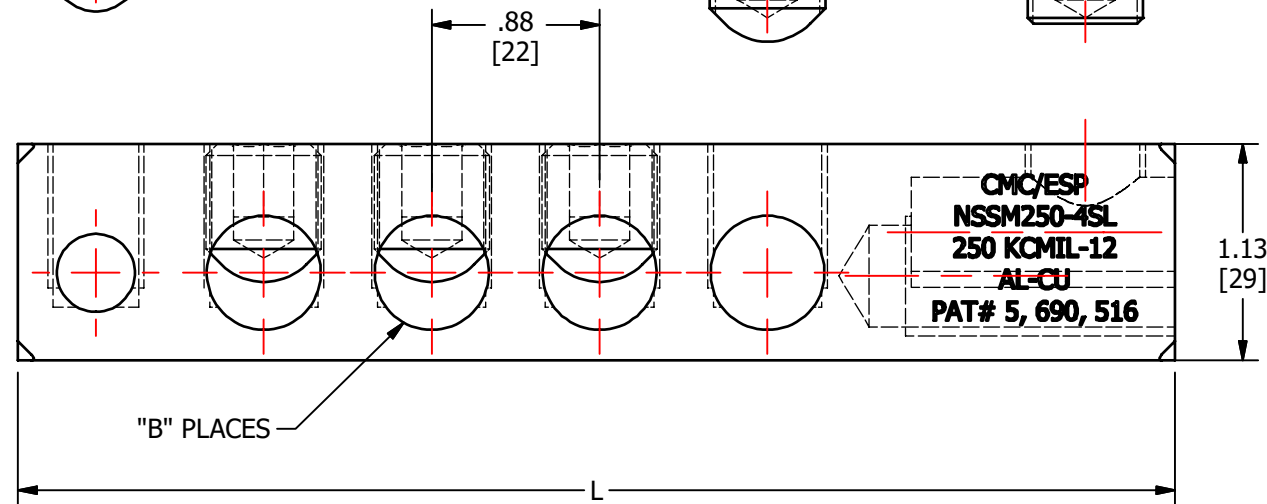
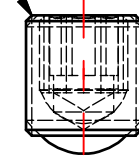

REV.	DESCRIPTION	ECN	DATE	INIT.
A	NEW DRAWING CREATED		01/30/19	TS

TO ORDER CMC PRODUCTS CALL 1-513-860-4455  
FOR PRODUCT INFO: <http://www.cmcugs.com>

DRAWN BY: TS 01/30/19	NAME OF PART: STUD MOUNT CONNECTOR	CAT. NO.: SEE TABLE
CHECKED BY:	DWG NO: C58700066-S (CHARTED)	B
DRAWING NOT TO SCALE		SHEET NO: 1 OF 1

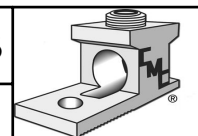

THIS INFORMATION IS PROPRIETARY TO CONNECTOR MFG. CO. AND IS NOT TO BE DISCLOSED OUTSIDE OF CONNECTOR MFG. CO. WITHOUT A CONFIDENTIALITY AGREEMENT



CONNECTOR MANUFACTURING CO.

HAMILTON, OHIO