

CATALOG NUMBER	L	B
NSM250-2I	3.50 [89]	2
NSM250-2	3.50 [89]	2
NSM250-3I	4.37 [111]	3
NSM250-3	4.37 [111]	3
NSM250-4I	5.25 [133]	4
NSM250-4	5.25 [133]	4
NSM250-6I	7.00 [178]	6
NSM250-6	7.00 [178]	6
NSM250-8I	8.74 [222]	8
NSM250-8	8.74 [222]	8

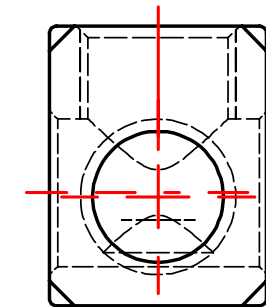

					TO ORDER CMC PRODUCTS CALL 1-513-860-4455	DRAWN BY: TS 11/19/18	NAME OF PART: STUD MOUNT CONNECTOR	CAT. NO.: SEE TABLE
					FOR PRODUCT INFO: <a href="http://www.cmclugs.com">http://www.cmclugs.com</a>	CHECKED BY:	DWG NO: C58700213-S (CHARTED)	A
A	NEW DRAWING CREATED		11/19/18	TS		DRAWING NOT TO SCALE		SHEET NO: 1 OF 1
REV.	DESCRIPTION	ECN	DATE	INIT.				

THIS INFORMATION IS PROPRIETARY TO CONNECTOR MFG. CO. AND IS NOT TO BE DISCLOSED OUTSIDE OF CONNECTOR MFG. CO. WITHOUT A CONFIDENTIALITY AGREEMENT

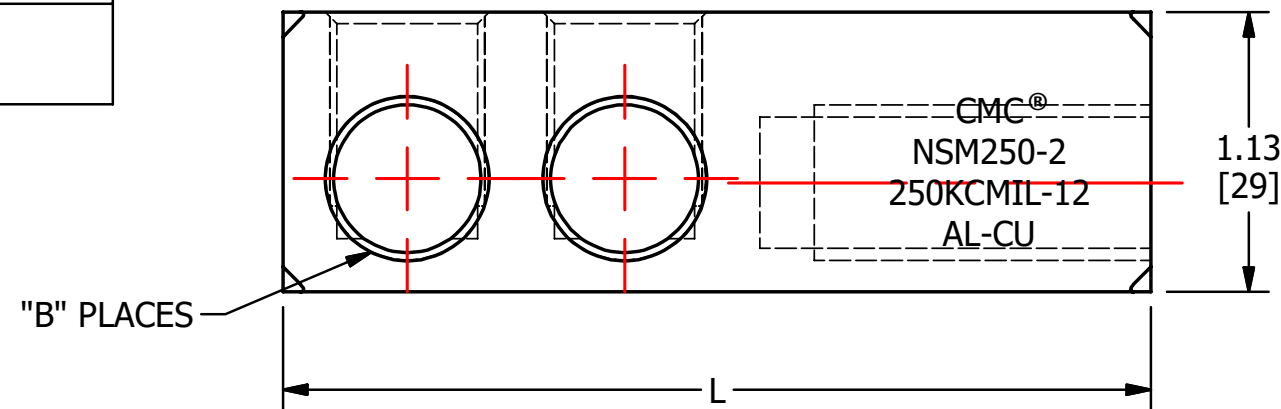
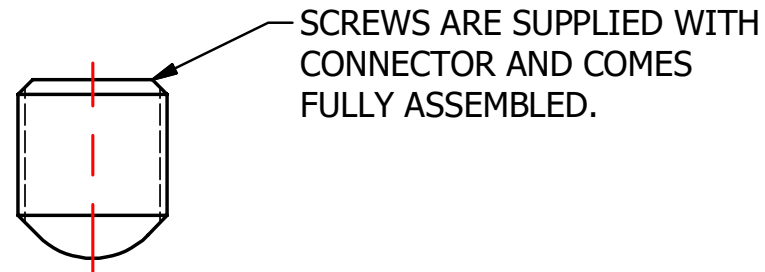
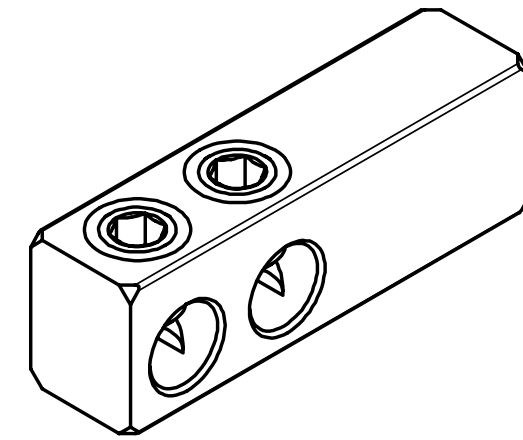
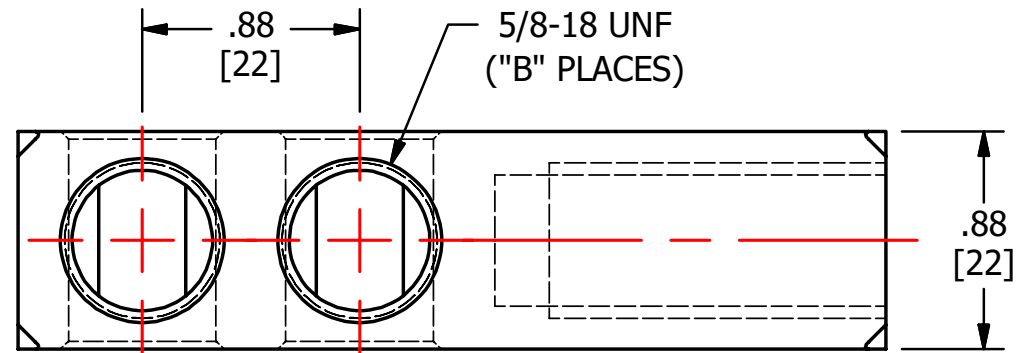

**CONNECTOR MANUFACTURING CO.**

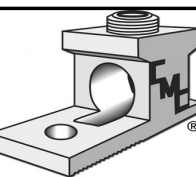

HAMILTON, OHIO