

S.NO	CATALOG NUMBER	L	A	B	C
1	6ABV-350MS	3.00 [76]	1.03 [26]	6	2
2	6ABV350MSI	3.00 [76]	1.03 [26]	6	2
3	8ABV-350MS	4.75 [121]	1.25 [32]	8	3
4	8ABV350MSI	4.75 [121]	1.25 [32]	8	3
5	10ABV-350MS	4.75 [121]	0.94 [24]	10	3
6	10ABV350MSI	4.75 [121]	0.94 [24]	10	3
7	12ABV-350MS	6.50 [165]	1.10 [28]	12	4
8	12ABV350MSI	6.50 [165]	1.10 [28]	12	4

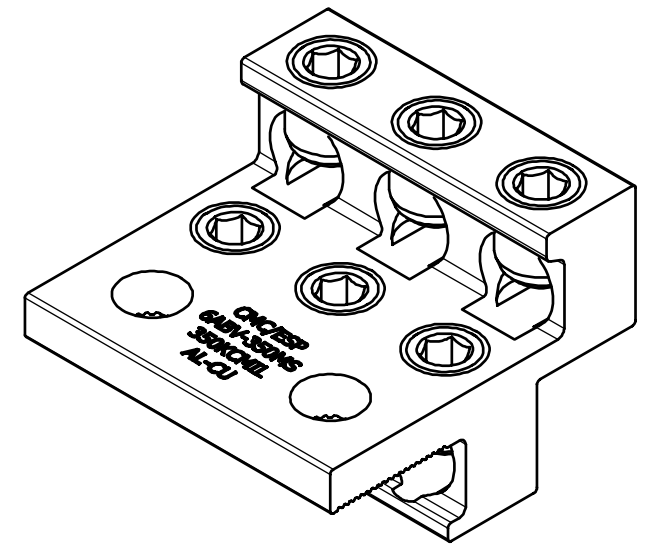

SCREWS ARE SUPPLIED WITH CONNECTOR AND COMES FULLY ASSEMBLED.

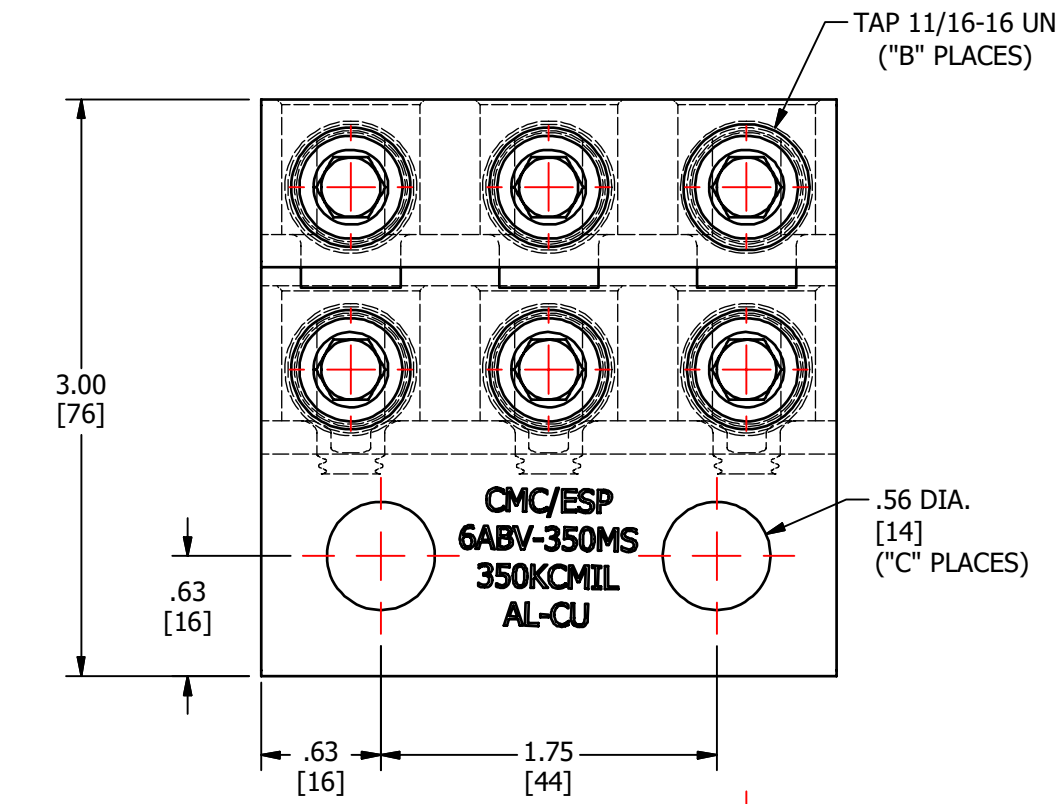
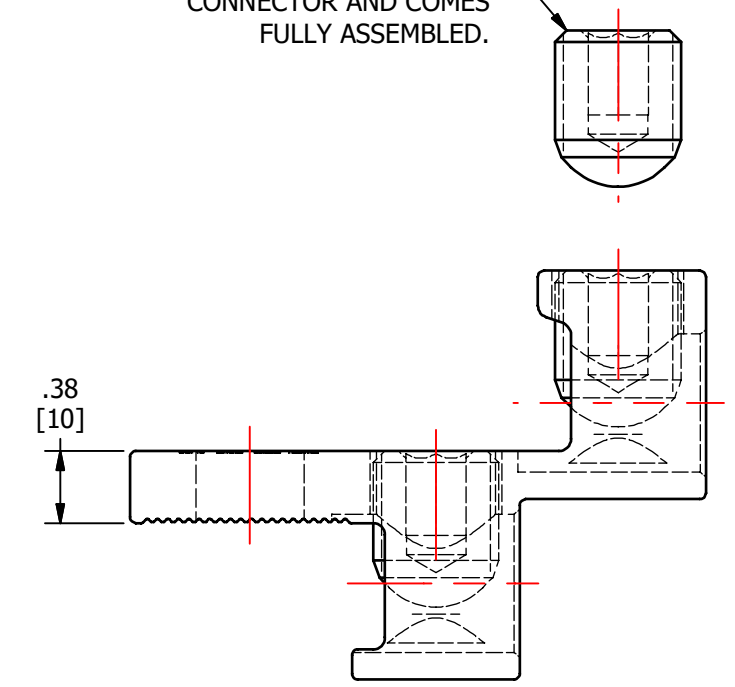
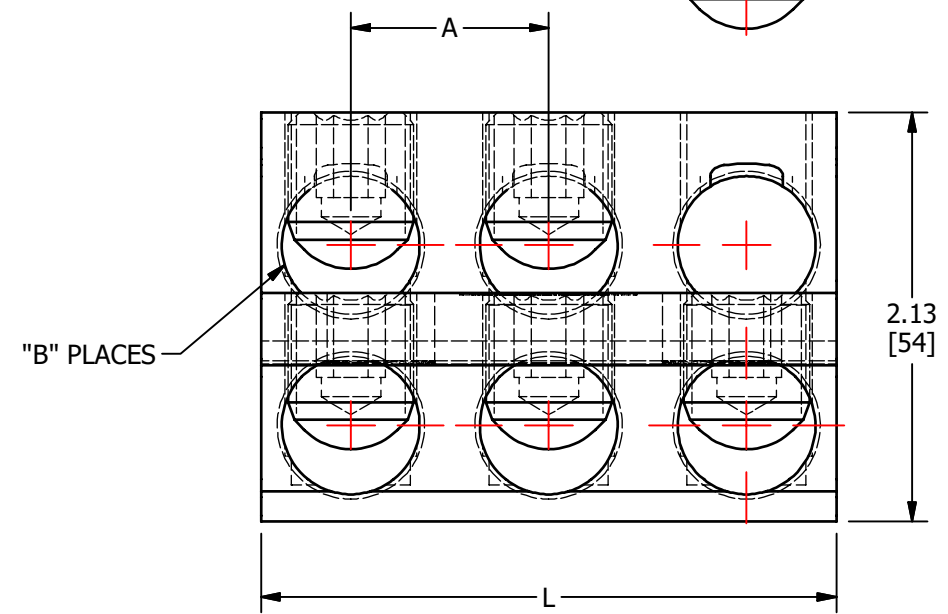

				TO ORDER CMC PRODUCTS CALL 1-513-860-4455		DRAWN BY: TS 01/23/19		NAME OF PART: LUG ASSEMBLY		CAT. NO.: SEE TABLE	
				FOR PRODUCT INFO: http://www.cmcclugs.com		CHECKED BY:		DWG NO: C58701100-S (CHARTED)		B	
A NEW DRAWING CREATED				01/23/19		TS		DRAWING NOT TO SCALE		SHEET NO: 1 OF 1	
REV.	DESCRIPTION	ECN	DATE	INIT.							

THIS INFORMATION IS PROPRIETARY TO CONNECTOR MFG. CO. AND IS NOT TO BE DISCLOSED OUTSIDE OF CONNECTOR MFG. CO. WITHOUT A CONFIDENTIALITY AGREEMENT



CONNECTOR MANUFACTURING CO.

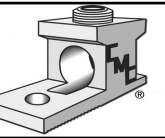

HAMILTON, OHIO